



**USER'S MANUAL**  
**Mast climbing work platform**

**FRSM**  
**2**  
**0K**



**20K User's manual**

**20K – «MAST DISTANCE TABLE» CORRECTION**

Table 17, page 151 of manual 9803046 rev 05

Data in table 17 revision 05 are wrong. The dimensions displayed in the table below have been corrected and will be officialised in further revisions. For all previous manual revisions, consider the dimension displayed in the document below.

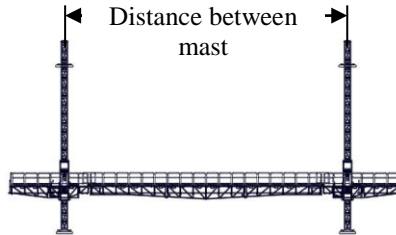


Tableau 17 - Distance between the masts

Configuration	Min distance	Standard distance	Max distance
Bridge section 20'-0" (6,1 m)	28'-7" (8,71 m)	28'-10" (8,79 m)	29'-1" (8,86 m)
Bridge section 20'-0" (6,1 m) + one (1) cantilever section 2'-6" (0,75 m)	31'-1" (9,47 m)	31'-4" (9,55 m)	31'-7" (9,63 m)
Bridge section 20'-0" (6,1 m) + two (2) cantilever section of 2'-6" (0,75 m) or one (1) cantilever section of 5'-0" (1,5 m)	33'-7" (10,24 m)	33'-10" (10,31 m)	34'-1" (10,39 m)
Bridge section 20'-0" (6,1 m) + one (1) cantilever section of 2'-6" (0,75 m) and one (1) cantilever section of 5'-0" (1,5 m)	36'-1" (11,00 m)	36'-4" (11,07 m)	36'-7" (11,15 m)
Bridge section 20'-0" (6,1 m) + two cantilever section of 5'-0" (1,50 m)	38'-7" (11,76 m)	38'-10" (11,84 m)	39'-1" (11,91 m)
Bridge section 40'-0" (12,2 m)	48'-6" (14,78 m)	49'-0" (14,94 m)	49'-6" (15,09 m)
Bridge section 40'-0" (12,2 m) + one (1) cantilever section of 2'-6" (0,75 m)	51'-0" (15,54 m)	51'-6" (15,70 m)	52'-0" (15,85 m)
Bridge section 40'-0" (12,2 m) + two (2) cantilever section of 2'-6" (0,75 m) or one (1) cantilever section of 5'-0" (1,5 m)	53'-6" (16,31 m)	54'-0" (16,46 m)	54'-6" (16,61 m)
Bridge section 40'-0" (12,2 m) + one (1) cantilever section of 2'-6" (0,75 m) and one (1) cantilever section of 5'-0" (1,5 m)	56'-0" (17,07 m)	56'-6" (17,22 m)	57'-0" (17,37 m)
Bridge section 40'-0" (12,2 m) + two cantilever section of 5'-0" (1,50 m)	58'-6" (17,83 m)	59'-0" (17,98 m)	59'-6" (18,14 m)
Bridge section 60'-0" (18,3 m)	68'-6" (20,88 m)	69'-0" (21,03 m)	69'-6" (21,18 m)
Bridge section 60'-0" (18,3 m) + one (1) cantilever section of 2'-6" (0,75 m)	71'-0" (21,64 m)	71'-6" (21,79 m)	72'-0" (21,95 m)
Bridge section 60'-0" (18,3 m) + two (2) cantilever section of 2'-6" (0,75 m) or one (1) cantilever section of 5'-0" (1,5 m)	73'-6" (22,40 m)	74'-0" (22,56 m)	74'-6" (22,71 m)
Bridge section 60'-0" (18,3 m) + one (1) cantilever section of 2'-6" (0,75 m) and one (1) cantilever section of 5'-0" (1,5 m)	76'-0" (23,16 m)	76'-6" (23,32 m)	77'-0" (23,47 m)
Bridge section 60'-0" (18,3 m) + two cantilever section of 5'-0" (1,50 m)	78'-6" (23,93 m)	79'-0" (24,08 m)	79'-6" (24,23 m)

For further information or any questions, please contact:  
 Fraco's technical department  
 Telephone: 450-658-0094  
 Toll Free: 800-267-0094  
 Fax: 450-658-8905

## Summary

<b>Chapter A - General Information and Operation</b> .....	<b>4</b>
<b>Revision table</b> .....	<b>4</b>
<b>Documentation and applied standards</b> .....	<b>4</b>
<b>Warranties</b> .....	<b>5</b>
FRACO warranty program .....	5
FRACO-Retailer warranty program .....	5
<b>Warnings</b> .....	<b>6</b>
<b>General view - Single mast</b> .....	<b>7</b>
<b>General view - Two-mast</b> .....	<b>8</b>
<b>General dimensions</b> .....	<b>10</b>
Dimensions with ground base .....	10
Dimensions with freestanding base (universal, 20K) .....	11
Minimum distances and clearances .....	11
<b>Display plates and stickers</b> .....	<b>14</b>
Identification and serial number plate.....	14
Stickers .....	15
<b>Documentation compartment</b> .....	<b>16</b>
<b>General Technical Specifications</b> .....	<b>17</b>
<b>Permitted configurations and load distribution</b> .....	<b>18</b>
Configuration – Single-mast.....	19
Configuration example (single-mast).....	21
Configuration - Double mast .....	22
Configuration example (Double mast, typical configuration).....	24
<b>Operation, use of the lifting unit</b> .....	<b>25</b>
Using the Lifting unit (electric).....	26
Using the lifting unit (descent).....	27
Control panel .....	28
Using the lifting unit (list of figures) .....	29
Using the inclinometer (if applicable*) .....	30
Emergency stop and descent procedure.....	31
Using and operating the Lifting unit.....	32
<b>Chapter B – Lifting Unit and Bases</b> .....	<b>34</b>
<b>Ground load and load distribution</b> .....	<b>34</b>
Ground load and maximum height .....	34
Ground load - Ground base (14030019) .....	34
Ground load - Universal freestanding base (14030109) .....	35
Ground load - Universal freestanding base (14030053) .....	36
<b>Chapter C – Installation and Dismantling</b> .....	<b>37</b>
<b>Installation</b> .....	<b>37</b>
<b>Locating the installation site and taking measurements</b> .....	<b>37</b>
Safety perimeter .....	37
Taking measurements and identifying the location of the lifting unit .....	37
<b>Handling and lifting operation</b> .....	<b>38</b>
Lifting points .....	38
Lifting, use of the mast end section.....	39
Use of lifting slings.....	39
Use of lifting slings (CONTINUED) .....	40
<b>Installing the base and lifting unit</b> .....	<b>41</b>
Installation with ground base (14030019) .....	41
Installation with universal freestanding base (14030109) .....	42
Installation with universal freestanding base (14030109) (CONTINUED) .....	43
Installation with 20K freestanding base (14030053).....	44
Installation of the guardrail with ladder .....	45
<b>Extension section</b> .....	<b>46</b>
MODULAR extension section .....	46
NON-MODULAR extension section .....	47
Installation of an extension section .....	48
Installation of an extension section (CONTINUED).....	49
Installation of extension section joints (20490566) .....	50
Installation of tapered extension sections with protective hook supports .....	51
<b>Bridge section</b> .....	<b>52</b>
MODULAR bridge section.....	52
NON-MODULAR bridge section.....	54
Installation of bridge section .....	55
Installation of bridge joint with bottle (20490577) .....	56
Installation of 15'-0" or 20'-0" individual bridge section between two (2) units.....	57
Installation of individual 15'-0" or 20'-0" bridge section on intermediate units and/or extensions.....	58
Installation of 30'-0" to 60'-0" bridge assembly between two (2) units and/or intermediate extensions.....	59
Installation of an extension bridge section.....	60
<b>Bolting mast sections and mast end section</b> .....	<b>61</b>

<b>Mast anchor</b> .....	<b>62</b>
Mast anchor specifications.....	62
Mast anchor opening constraints .....	64
Installation of the mast attach device (typical).....	71
<b>Lifting unit operation specifications</b> .....	<b>72</b>
<b>Installation/dismantling of mast sections</b> .....	<b>73</b>
Installation of mast sections and anchor devices / 20K platform with ground base.....	74
Installing mast sections and anchoring devices / 20K Platform with ground base (continued) .....	75
Installing mast sections and anchoring devices / 20K Platform with ground base (continued) .....	76
Installation of mast sections and anchor devices / 20K platform with freestanding base (Universal and 20K) .....	77
Installation of the self-erecting system (optional).....	80
Mast levelling with anchor devices .....	81
Installation of the protection screen .....	82
Disassembly of masts and anchors with ground base.....	83
Disassembly of masts and anchors with ground base (CONTINUED).....	84
Disassembly of anchors with freestanding base (universal, 20K) .....	85
Disassembly of anchors with freestanding base (universal, 20K) (CONTINUED).....	86
<b>Chapter D - Accessories</b> .....	<b>87</b>
<b>Bridge and extension accessory</b> .....	<b>87</b>
Installation of guardrail pocket holders and guardrails.....	87
Installing the outriggers.....	88
Configuration of the outriggers.....	89
Detail of plankings and end of plank guardrail.....	93
Installation of outrigger supports for inside corner return (optional) .....	94
Installation of end outrigger guardrail.....	95
Installation of access guardrails to mast anchor devices .....	96
Installing anti-pivot device, small wheel (optional).....	97
Installing anti-pivot device, large wheel (optional) .....	98
Installation of the descent stop .....	99
Installation of the inclinometer .....	100
<b>Reinforced corner return support system with counterweight</b> .....	<b>101</b>
<b>Indoor work system</b> .....	<b>106</b>
<b>Rigid roof system</b> .....	<b>107</b>
<b>Winter shelter system</b> .....	<b>113</b>
<b>Monorail on platform</b> .....	<b>117</b>
<b>Mast head monorail</b> .....	<b>121</b>
<b>Crane FRH-2500</b> .....	<b>128</b>
Installation .....	129
Operation .....	130
Loading areas.....	131
Periodic maintenance .....	132
<b>Crane FRH-4000</b> .....	<b>133</b>
Installation .....	133
Operation .....	135
Loading areas.....	136
Periodic maintenance .....	137
Installation of the built-in self-erecting system (optional) .....	138
<b>Freestanding mobile base</b> .....	<b>139</b>
Assembly.....	139
Mobile base use .....	144
<b>Index</b> .....	<b>146</b>
<b>Technical data sheets</b> .....	<b>146</b>
Lifting unit technical data sheet.....	146
Technical data sheet of the ground base .....	147
Technical data sheet of the universal freestanding base.....	148
Technical data sheet of the FRSM-20K freestanding base.....	149
Mast sections technical data sheet .....	150
<b>Distance between the masts</b> .....	<b>151</b>
<b>Extensions and bridges (non-modular)</b> .....	<b>152</b>
<b>Extensions and bridges (modular)</b> .....	<b>153</b>
<b>Periodic maintenance</b> .....	<b>154</b>
Daily .....	154
Weekly .....	154
Monthly.....	154
Other .....	154
Daily inspection grid .....	155
Spare parts.....	156
Assistance .....	157
<b>CE Declaration</b> .....	<b>159</b>
.....	<b>159</b>
<b>Lists of figures</b> .....	<b>160</b>

# Chapter A - General Information and Operation

## Revision table

Revision N°	Description	Date (yyyy-mm-dd)
04	General revision	2017-01-10
05	General revision	2017-11-01
06	Updated torque reduced for mast sections assembly	2018-05-07

## Documentation and applied standards

Brand: FRACO

Model: FRSM-20K

Serial number: \_\_\_\_\_

- Machine Directive 2006/42/EC
- ANSI/SIA A92.9-2011: Mast-Climbing Work Platforms
- CSA B354.5 : Mast-Climbing Work Platforms

Produced by:

**Les Produits FRACO Ltée**

91, chemin des Patriotes

Saint-Mathias-sur-Richelieu

Quebec, J3L 6B6, Canada

(450) 658-0094 / [www.fraco.com](http://www.fraco.com)

**NOTE:** The term « FRACO » in this document refers to the company « Les Produits FRACO Ltée » and its subsidiaries. All drawings and illustrations in this document are for information purposes only. The actual product may differ. Specifications and technical data are subject to change without notice. Be sure to always have the latest version of this document.

© Les Produits FRACO Ltée All rights reserved.

*Reproduction in whole or in part of the contents of this document by any means is strictly prohibited without prior written consent of Les Produits FRACO Ltée.*

## Warranties

### FRACO warranty program

#### The warranty period:

**A)** The warranty period begins on the initial date of retail purchase by an authorized FRACO dealer. Les Produits FRACO Ltée warrants that the products distributed by Les Produits FRACO Ltée, which have defaults in normal usage condition, when installed and handled in accordance with the instructions provided to the consumer, will be repaired free of charge for parts and labour costs. Parts supplied under this warranty may be new or refurbished as selected by FRACO Ltée.

**B)** The warranty period for retail customers leasing the products begins on the date the product is first commissioned: a) during the leasing period; b) at the date of the retail sale; as defined in A).

#### The product:

FRACO unit (new)-----One (1) year, parts and labour

FRACO Unit (used)-----Three (3) months, parts and labour

Note: The warranty on used units is only applicable to used products sold directly by FRACO.

Said product warranty shall be applicable for its entire duration, whether the products are owned by the original owner or by a subsequent owner.

Parts: Les Produits FRACO Ltée must be notified in writing of any parts breakage within the warranty period. For parts to be replaced or repaired and for service requests, said broken parts or unit shall be delivered, at the owner's expense, to an authorized FRACO dealer. Each part replaced within the warranty period is covered by a new 3-month warranty period for parts and labour.

#### What is not covered:

This warranty does not apply if the FRACO security seal is damaged, destroyed or missing.

This warranty does not cover changes not authorized in writing by Les Produits FRACO Ltée or parts that are not genuine FRACO parts.

This warranty does not apply if the serial numbers on the rack and identification plates are damaged, destroyed or missing.

#### To get service and parts:

FRACO Products Ltée has a number of retailers in Canada and the United States to assist you with repairs. To qualify for warranty coverage, you must complete a warranty claim form.

Date of commissioning: \_\_\_\_\_

Serial number: \_\_\_\_\_

### FRACO-Retailer warranty program

#### Parts:

Retailers who honour warranties on behalf of: FRACO Products Ltée will be required to identify and retain all replaced parts for a period of one year from the date of the claim.

#### Labour:

The work performed by an authorized FRACO dealer will be reimbursed based on the hours and authorized rate by Les Produits FRACO Ltée.

## Warnings

This manual is intended for anyone involved in the assembly, disassembly, use and/or maintenance of the platform.

**Before installing, dismantling, operating or maintaining** the platform, you must read and fully understand the instructions detailed in this manual. Failure to comply with these safety instructions may result in property damage, severe injury and even death. FRACO and/or its representative shall not under any circumstances be held responsible. All current local standards and regulations regarding safety and accident prevention, environmental protection and other activities related to the assembly, dismantling, use and maintenance of this type of equipment are considered as a supplement to this manual and must be strictly adhered to, for example the wearing of personal protective equipment (harness, helmet, boots, etc.).

**Safety is our priority!** For this reason, never remove or modify a part in order to adapt the platform to a particular condition. Contact FRACO for any assistance.

Only use genuine FRACO parts.

This manual is considered an integral part of the platform and is mandatory for communicating the necessary safety information to operators and users. A copy of this manual must always be included in the waterproof compartment provided for this purpose on the platform.

∞SEE DOCUMENTATION COMPARTMENT, ON PAGE 16.

Be sure to read and understand all the stickers, warnings and instructions displayed on the equipment, or to obtain an explanation from a qualified person.

### Remember that:

- An **operator** must have successfully completed the **Level 1 (Safety and User)** training and hold a valid training card, be familiar with the contents of this manual and fully understand the applicable platform usage rules;
- An **installer** must have successfully completed the **Level 2A or 2B (Installation)** training and hold a valid training card, be familiar with the contents of this manual and fully understand the applicable platform usage rules;
- For security reasons, a **minimum of two (2) people** must be present at all times on each platform during assembly, disassembly, maintenance or use;
- Local regulations may require that the platform be permanently equipped with a fire extinguisher. Its position should be signalled on the platform in order to be readily located.

**IN CASE OF FIRE:** Stay calm and notify the people present on the platform. If available, use the fire extinguisher following the instructions provided. If the fire is out of control, evacuate the platform through the nearest access.


Local regulations may require adequate protection of the platform in the event of an electrical storm.

**IMPORTANT:** Refer to the section **OPERATION, USE OF THE LIFTING** unit for additional safety instructions concerning the use of the platform.

∞SEE OPERATION, USE OF THE LIFTING unit, ON PAGE 25.

If, after consulting this manual, you have any doubts about the assembly, dismantling, use or maintenance of the platform, contact FRACO.

In this manual, the following symbols and annotations are used:

Symbol	Description
 <b>Danger</b>	<b>Major</b> risks of personal and/or material damage to survival and safety
<b>Warning</b>	Risks of personal injury and/or property damage
<b>Important!</b>	Important points to monitor

### RESIDUAL hazards:

Despite all the precautions taken, potential residual risks exist such as:

- Injuries resulting from uncoordinated tasks
- Malfunction of a control system
- Working with an electrical system
- Damage to transportation equipment
- Fall of badly secured objects
- Strong winds
- Entrance and exit
- Loud noises
- Dust
- Or any other work-related risk, etc.

## General view - Single mast

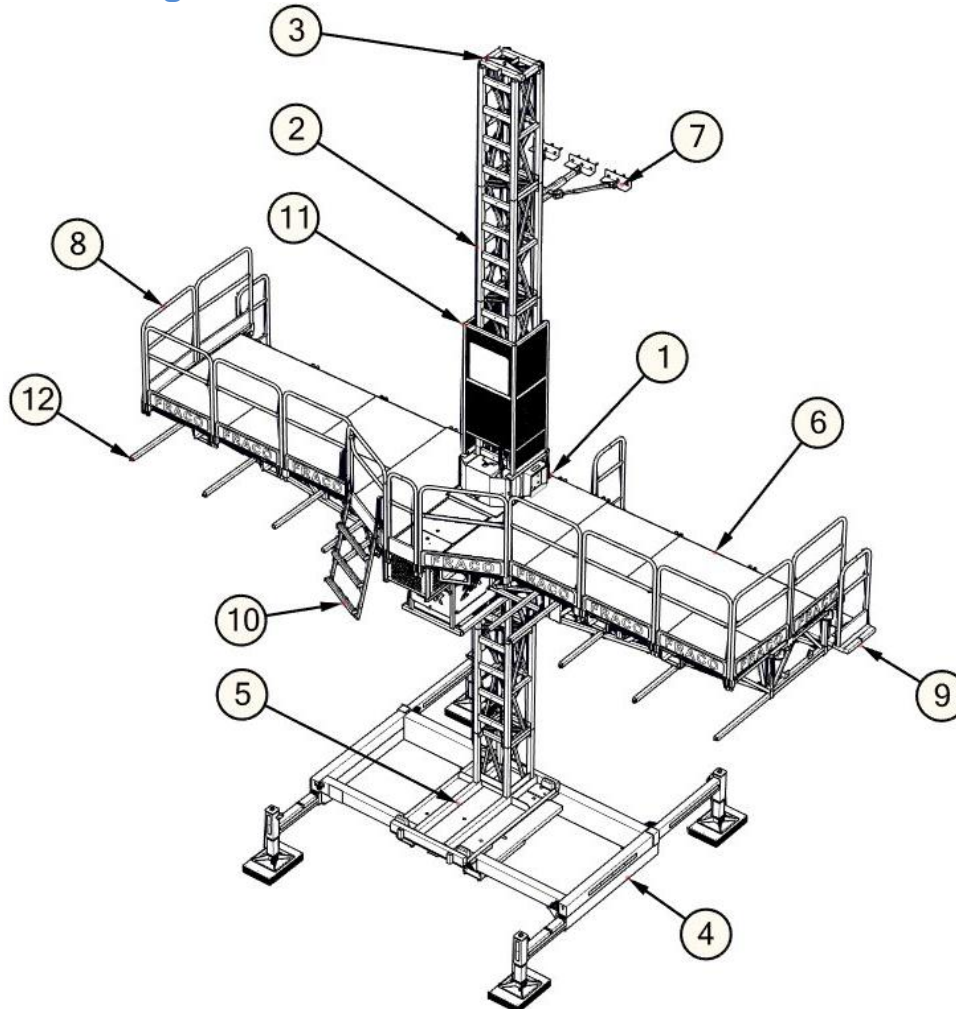


Figure 1 - FRSM-20K single-mast with freestanding base

No	Item	Description	No	Item	Description
1	10060018	FRSM-20K Elevating unit (Gas)	7	XXXXXXXXX	Mast anchor
2	13030041	Mast section (20" x 20" x 5'-0") with rung (FRSM-20K)	8	17490023	Guard-rail (3'-4" x 4'-2")
3	13030029	End mast section for 20" x 20" mast	*9	XXXXXXXXX	Plankings
4	14030109	Universal freestanding base	10	28494209	Stairs
5	14030019	Ground base for 20" x 20" mast (3'-6" x 6'-0")	11	20490646	Protective mesh
6	1509XXXX	Extension section	12	190XXXXX	Outriggers

\*The planking is not supplied by FRACO.



## General view - Two-mast

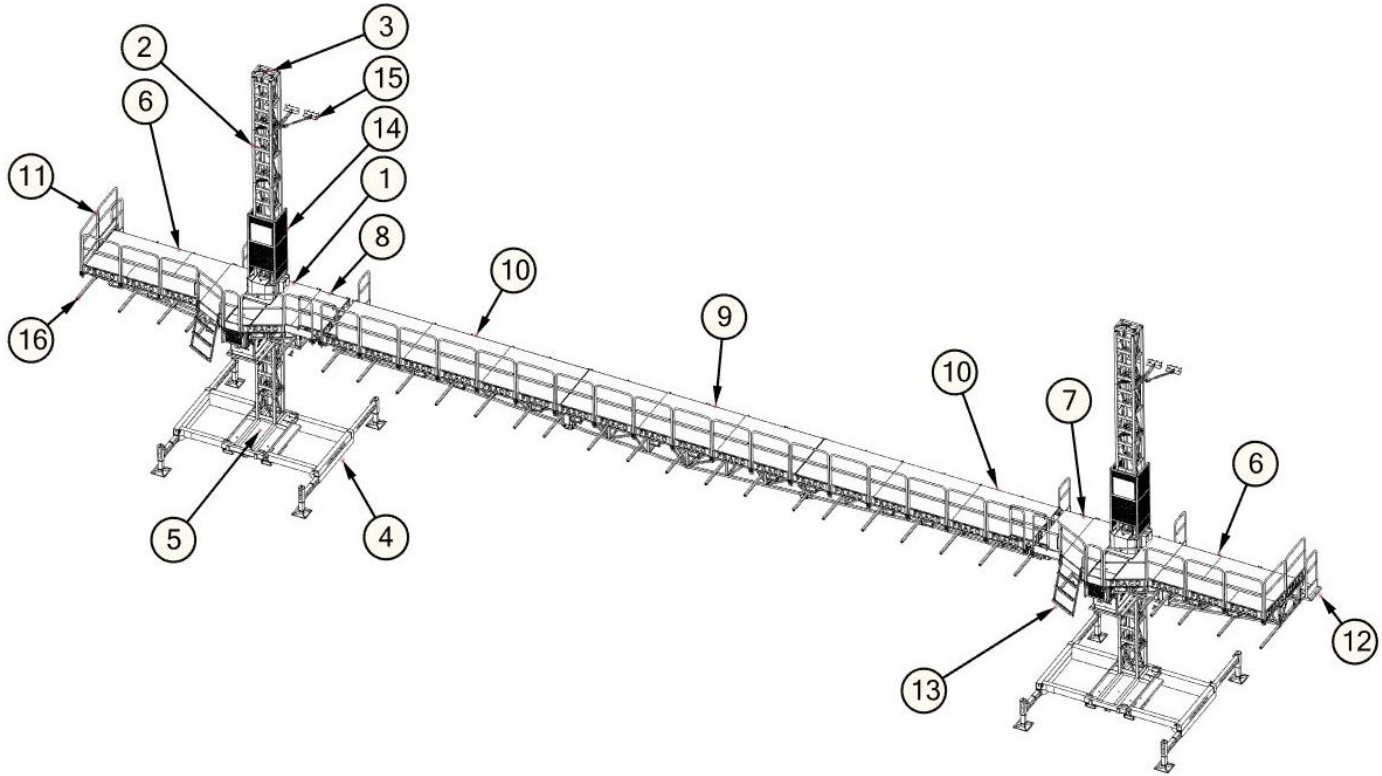


Figure 2 - FRSM-20K two-mast with freestanding base

No	Item	Description	No	Item	Description
1	10060018	FRSM-20K Elevating unit (Gas)	9	1509XXXX	Central bridge section
2	13030041	Mast section 20" x 20" x 5'-0" with bars (FRSM-20K)	10	1509XXXX	Bridge section
3	13030029	End mast section for 20" x 20" mast	11	17490023	Guard-rail (3'-4" x 4'-2")
4	14030109	Universal freestanding base	*12	XXXXXXXXXX	Plankings
5	14030019	Ground base for 20" x 20" mast (3'-6" x 6'-0")	13	28494209	Stairs
6	1509XXXX	Extension section	14	20490646	Protective wire mesh
7	1509XXXX	Intermediate-G extension section	15	XXXXXXXXXX	Mast anchor
8	1509XXXX	Intermediate-D extension section	16	190XXXXXX	Outriggers

\*The planking is not supplied by FRACO.

## Regulatory attachment points

**Important! Wear your safety harness at all times when installing or dismantling mast sections, mast fasteners or when handling plankings in the work area.**

Workers exposed to fall hazards must wear a safety harness certified in accordance with current local standards. The fall arrest device must be able to withstand a load of 5 000 lb (2 270 kg) and may be equipped with a shock absorber. The attachment points presented in [Figure 3](#) of this document comply with current standards. We remind you, however, that improper use of the fall protection device may increase the risk of injury. Therefore, we recommend that you follow the proper training on the use of such fall protection systems before executing any works at heights.

**Important!**

- 1 worker per individual attachment point.
- Visually inspect the condition of an attachment point before attaching the harness.
- Never use an attachment point showing a deformation in the steel.

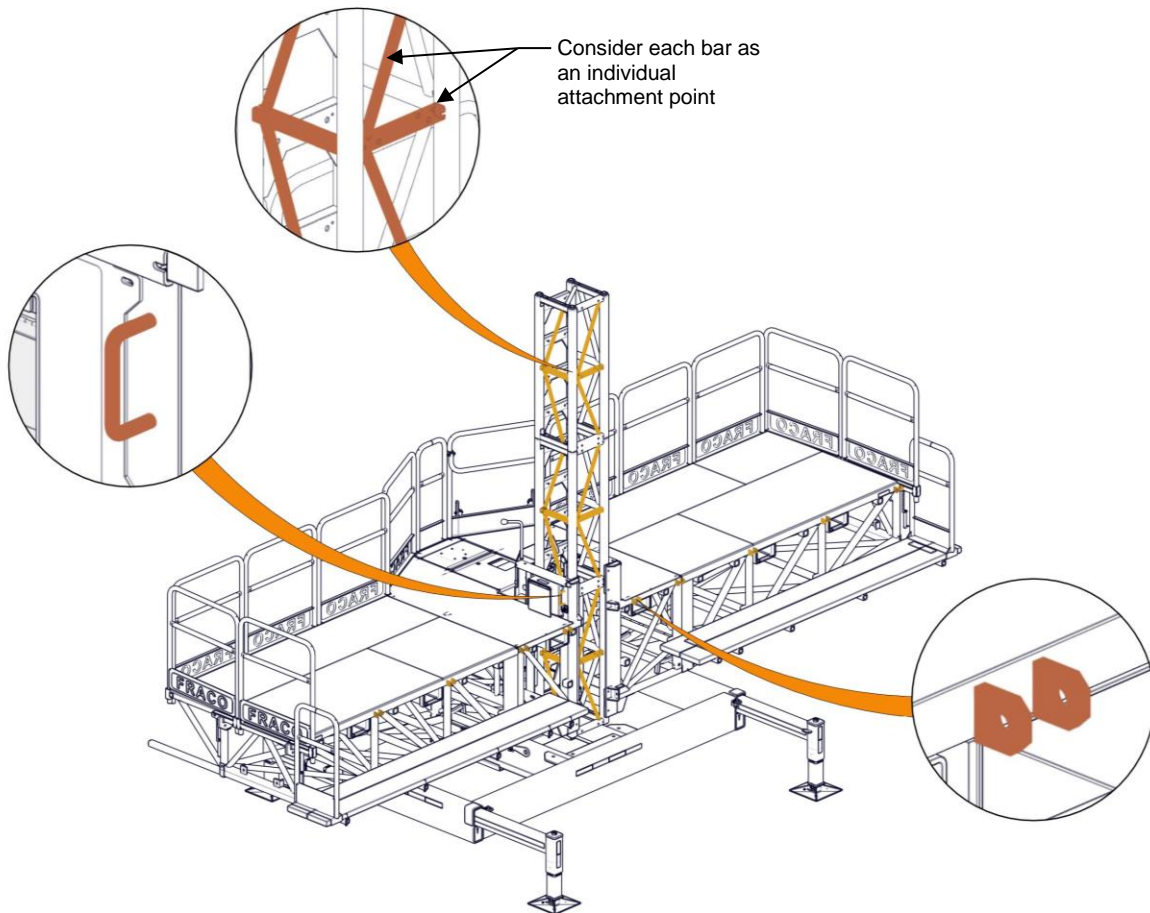


Figure 3 - Regulatory attachment points

## General dimensions

### Dimensions with ground base

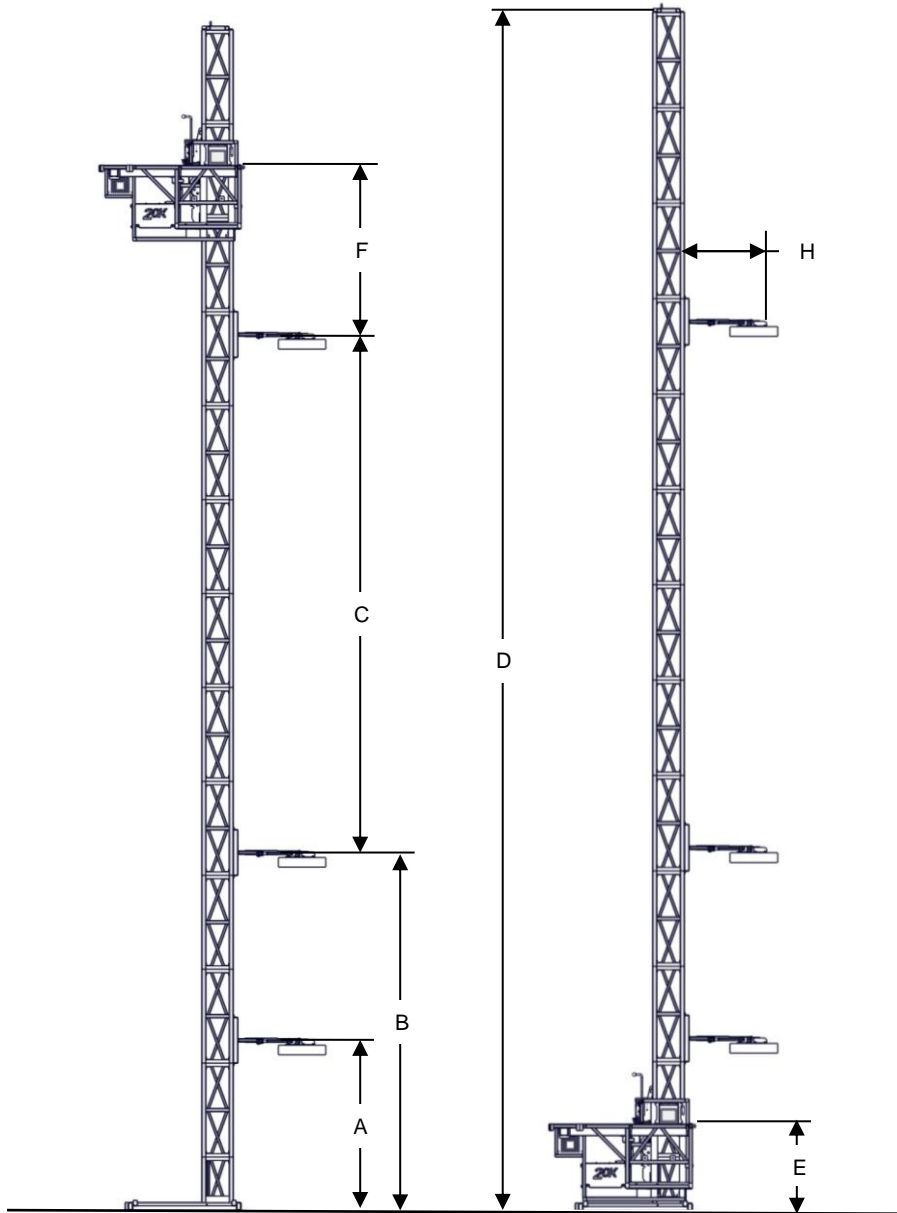


Figure 4 - Dimensions with ground base

### Dimensions with freestanding base (universal, 20K)

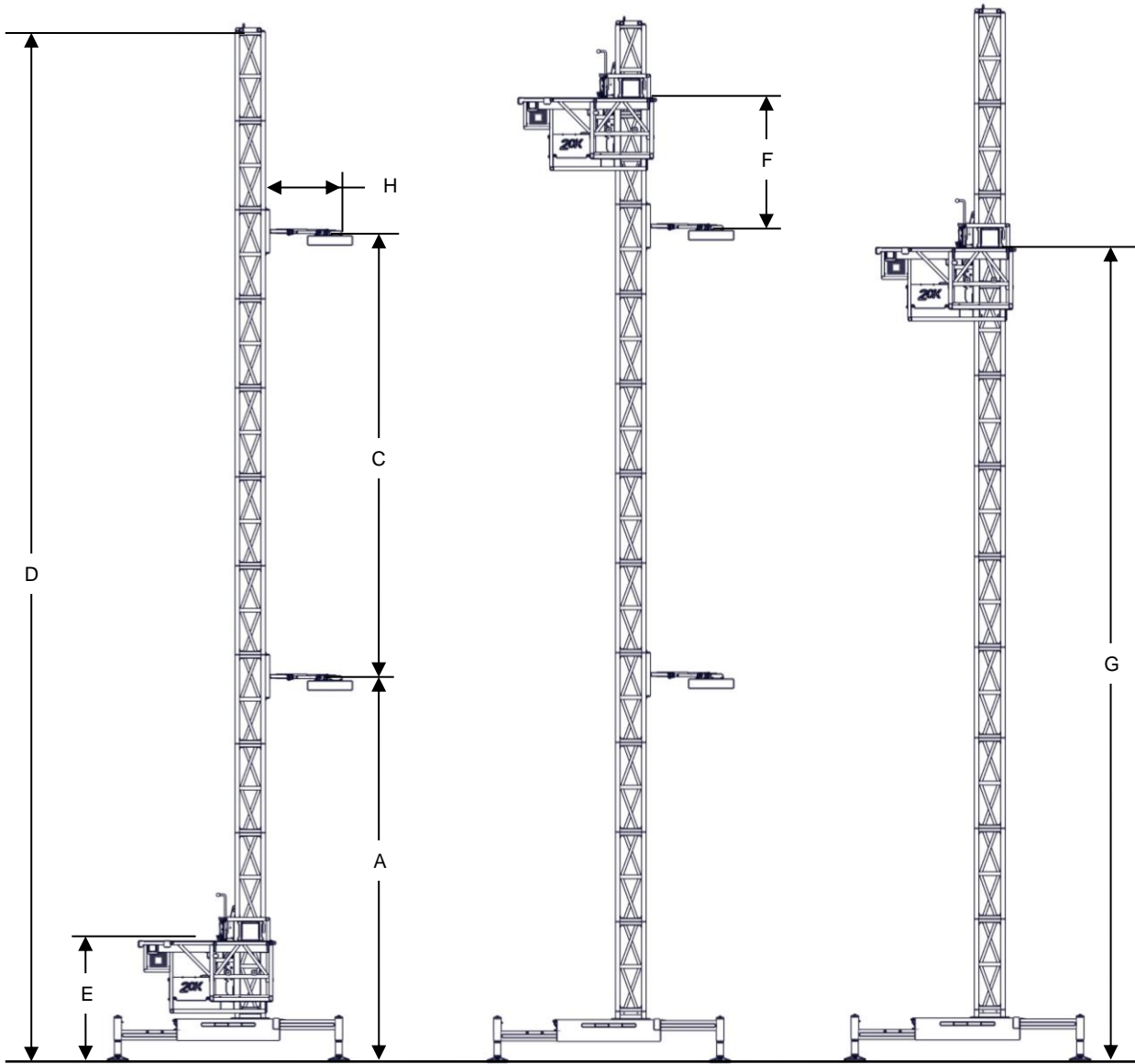


Figure 5 - Dimensions with freestanding base

### Minimum distances and clearances

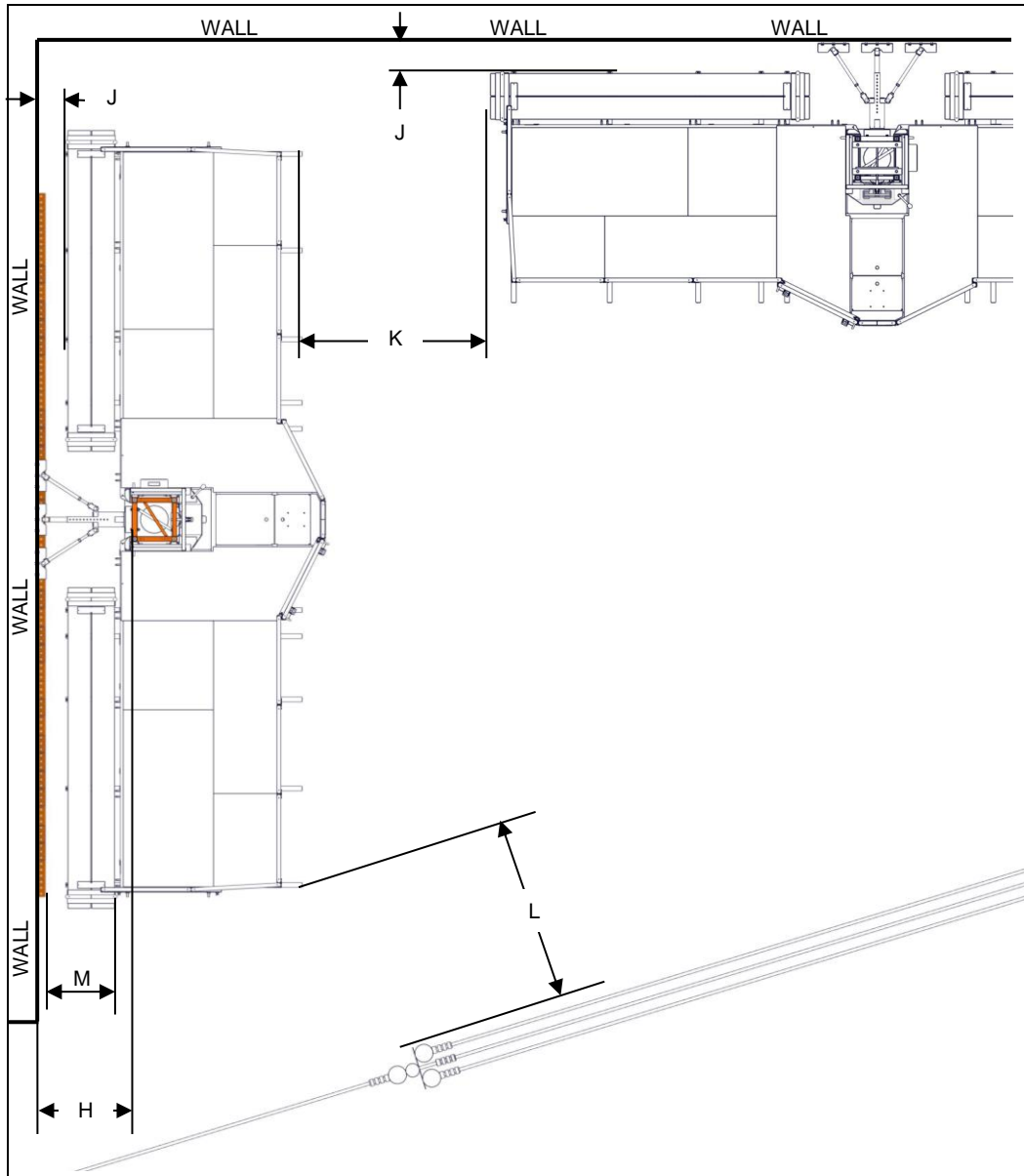


Figure 6 - Clearance to finished walls and around the units

**Table 1 - Dimensions and clearance**

	Description	With ground base	With freestanding base
A	Height of first mast anchor	Recommended 10'-0" (3,0 m)*	30'-0" (9,0 m) 45'-0" (13,7 m)**
B	Height of second mast anchor	Recommended 20'-0" (6,1 m)* Maximum 30'-0" (9,0 m)	N/A
C	Distance between mast anchors	31'-0" (9,5 m) ± 5'-0" (1,5 m)	
D	Maximum total installation height	550'-0" (168 m)	550'-0" (168 m) ± 200'-0" (61 m)
E	Minimum floor height	33" (838 mm) 47-1/2" (1 206 mm)***	60" (1 524 mm) 74-1/2" (1 892 mm)***
F	Maximum height above last mast anchor during use	5'-0" (1,5 m) †	5'-0" (1,5 m) †
G	Maximum freestanding height	<b>Configuration prohibited</b>	45'-0" (13,7 m) With universal base  40'-0" (12,2 m) With 20K freestanding base
H	Distance between the front of the mast and the anchor plate (mast anchor length)	<b>With 6" (152 mm) wall fixture</b> [Min 16" (406 mm) - Max 22" (559 mm)] <b>With 16" (406 mm) wall fixture</b> [Min 26" (660 mm) - Max 30" (762 mm)] <b>With 2'-3" (686 mm) wall fixture</b> [Min 34" (864 mm) - Max 72" (1 830 mm)] Max 72" (1 830 mm) ‡	
J	Clearance between platform and wall / structure / obstacle	Min 6" (152 mm) Max 14" (356 mm) ‡ [MIN 14" (356 mm) - MAX 18" (457 mm)] *****	
K	Clearance between adjacent platforms	Min 14" (356 mm)	
L	Clearance between platform and power lines	According to current local regulations	
M	Distance between the front of the unit and the finished wall	Depends on the length of the anchors	

Note: « freestanding » means any operational assembly of the unit on a mast without the use of any mast anchor device.

Note: The « front of the unit » is defined as the side of the unit facing the wall and the « rear of the unit » as the side with the circulatory area.

\* The first two (2) anchors may be installed up to a maximum of 30'-0" (9,0 m) provided that a minimum spacing of 5'-0" (1,5 m) is maintained between the first and the second anchor.

\*\* If the first mast anchor (A) is installed higher than 30'-0" (9,0 m), the maximum installation height (D) is 200'-0" (61 m). Therefore, any installation height greater than 100'-0" (30,5 m) requires wooden support blocks to be placed directly under the mast.

\*\*\* With tapered extension section.

\*\*\*\* From 14" (356 mm), guardrails must be used at the edge of the facade.

\*\*\*\*\* For facade plastering operations, the distance must be [MIN 14" (356 mm) - Max 18" (457 mm)] and no guardrails should be used.

† No accessories (winter shelter, portable crane, monorail, etc.).

‡ For a distance (H) greater than 72" (1 830 mm), contact FRACO for special parts.

## Display plates and stickers

### Identification and serial number plate

These identification plates are located on the lifting unit and must be visible at all times. The serial number is both available on the identification plate and engraved on the steel frame above the plate.

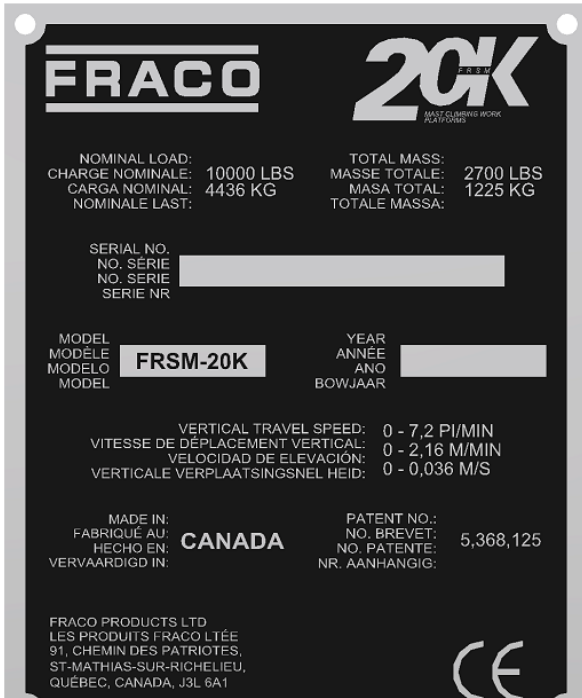


Figure 7 - Identification Plate

#### Reading a serial number:

#XX YY ZZZZ = XX (Model number) YY (Year of manufacture) ZZZZ (platform number)

Be sure to read and fully understand all signs, warnings and instructions displayed on the platform.

Ensure that this information is at all times visible, legible and in good condition.

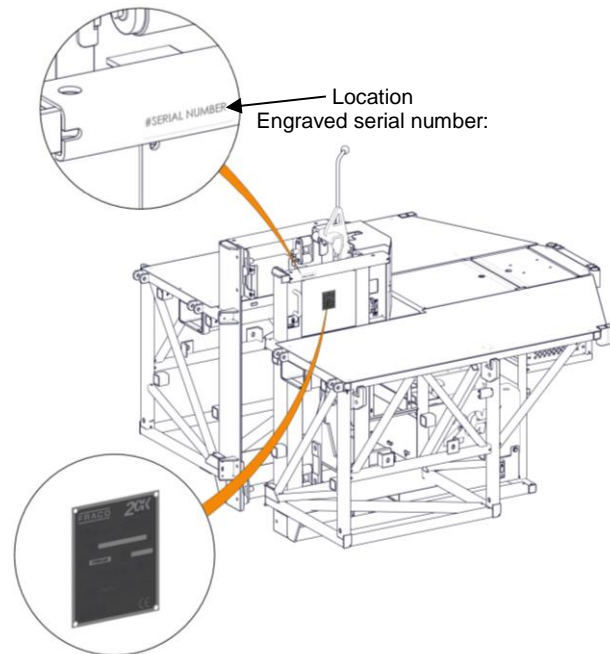


Figure 8 - Plate and Serial Number location

## Stickers

<p>1</p> <p>(30010891) Figure 9 - Emergency descent sticker</p>		
<p>2</p> <p>(30030118) Figure 10 - Engine choke sticker</p>	<p>3</p> <p>(30050255) Figure 11 - Choke knob sticker</p>	<p>7</p> <p>(30050143) Figure 12 - Valve selector sticker</p>
<p>4</p> <p>(30490220) Figure 13 - Hydraulic oil sticker</p>		
<p>5</p> <p>(30490220) Figure 14 - Harness attachment point</p>		
<p>6</p> <p>(30050266) Figure 15 - Emergency descent sticker</p>		



## Documentation compartment

The waterproof compartment on the lifting unit contains important documentation such as the (maintenance manuals), (user manual) and (engine manufacturer's manual). The document holder is located under the engine access panel.

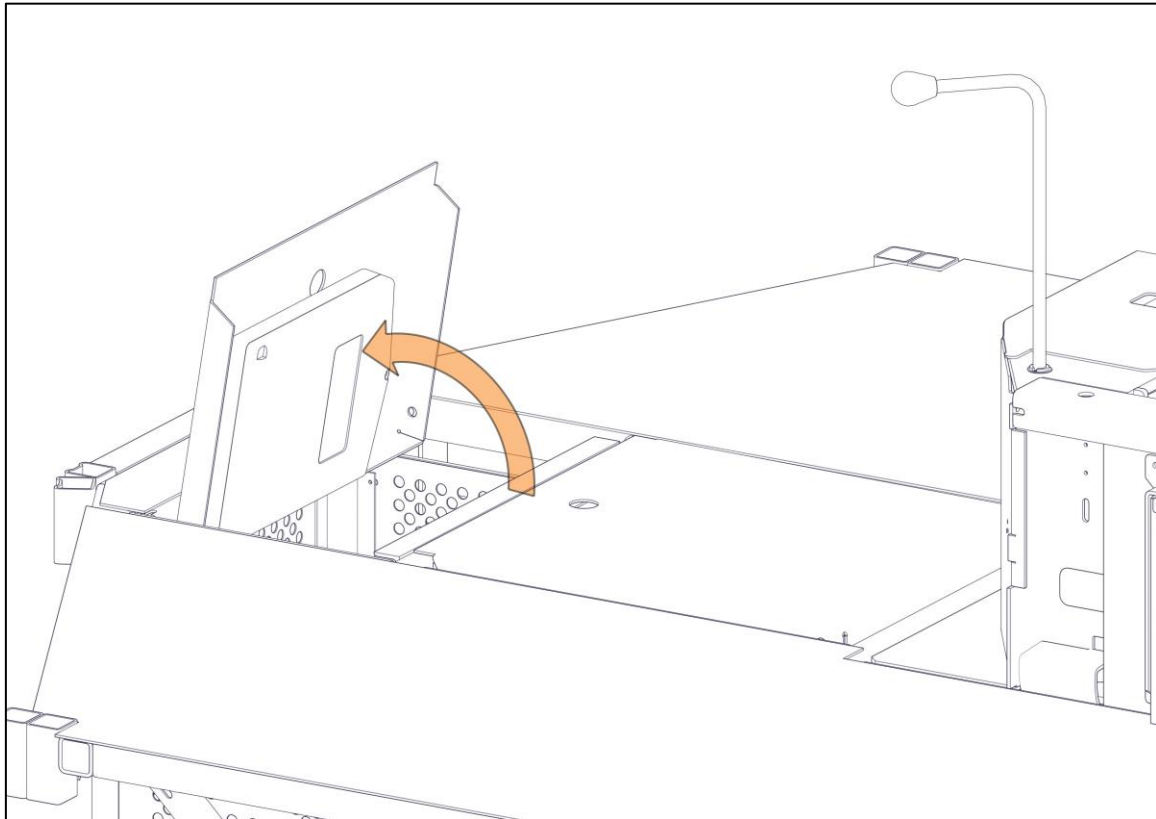


Figure 16 - Documentation compartment

## General Technical Specifications

**Table 2- Technical Specifications**

FRACO 20K – Specifications	Data
<ul style="list-style-type: none"> <li>Maximum load capacity:</li> <li>Reduced load capacity:</li> </ul>	10 000 lb (4 535 kg) / mast 5 000 lb (2 268 kg) / mast
<ul style="list-style-type: none"> <li>Maximum load during installation and dismantling:</li> </ul>	4 500 lb (2 041 kg) / mast
<ul style="list-style-type: none"> <li>Lifting speed (gas)*:</li> </ul>	0-7,2 ft/min (0-2,2 m/min)
<ul style="list-style-type: none"> <li>Engine type (gas)*:</li> </ul>	Honda GX390_13HP & GX160_5.5HP*
<ul style="list-style-type: none"> <li>Maximum platform length (single mast)</li> </ul>	<ul style="list-style-type: none"> <li>Full load 47'-6" (14,5 m)</li> <li>Reduced load 67'-6" (20,6 m)</li> </ul>
<ul style="list-style-type: none"> <li>Maximum platform length (Double mast)</li> </ul>	<ul style="list-style-type: none"> <li>Full load 127'-0" (38,7 m)</li> <li>Reduced load 133'-8" (40,7 m)</li> </ul>
<ul style="list-style-type: none"> <li>Maximum assembly height (without anchor)</li> <li>Maximum assembly height (with anchors)</li> </ul>	<ul style="list-style-type: none"> <li>(45 ft / 13,7 m)</li> <li>(550 ft / 168 m)</li> </ul>
<ul style="list-style-type: none"> <li>Typical spacing between anchors</li> </ul>	30'-0" (9,1 m)
<ul style="list-style-type: none"> <li>Maximum height above last anchor during operation of the unit</li> </ul>	5'-0" (1,5m)
<ul style="list-style-type: none"> <li>Mast section bolts**</li> </ul>	Ø1"-8unc x 6-½" gr8 zinc ( <b>A325 not allowed</b> ) **
<ul style="list-style-type: none"> <li>Tightening torque of bolts on mast section</li> </ul>	265 lb-ft (360 Nm)
<ul style="list-style-type: none"> <li><u>Maximum permissible wind speeds:</u></li> <li>During assembly</li> <li>During operation (without anchors)</li> <li>During operation (with anchors)</li> <li>Out of service (without anchors)</li> <li>Out of service (with anchors)</li> </ul>	<ul style="list-style-type: none"> <li>0 to 28 mph (45 km/h)</li> <li>0 to 22 mph (35 km/h)</li> <li>0 to 35 mph (55 km/h)</li> <li>22 to 80 mph (35 to 130 km/h)</li> <li>35 to 103 mph (56 to 168 km/h)</li> </ul>
<ul style="list-style-type: none"> <li>Lifting system</li> </ul>	Lifting hydraulic system with jack

\*Available in some countries only.

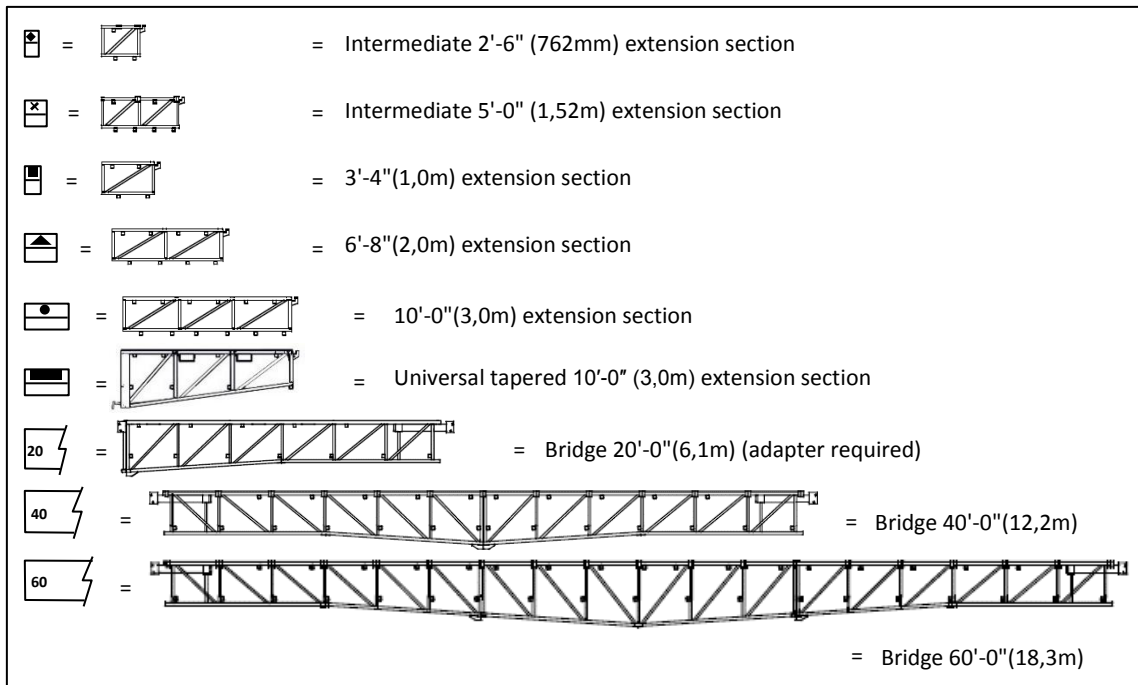
\*\*Any bolting for the mast section must be done with zinc plated Grade 8 certified bolting kits. On the other hand, the bolting between the bases and the basic components may be done with Grade 8 or A325 certified bolting kits,

## Permitted configurations and load distribution

**Notes:**

- The combined weight of all accessories present on the platform must be deducted from the total allowable load.  
∞ SEE TABLE 18 - LOAD DEDUCTIONS, ON PAGE 158  
∞ SEE TECHNICAL DATA SHEETS, ON PAGE 146
- The load distribution must be observed at all times.
- The weight of the workers must be deducted from the total allowable load. Always consider a minimum of two (2) workers per unit present in case of an emergency. Consider that a worker has an average weight of 175 lbs (80 kg) and his equipment approximately 88 lb (40 kg). Consider the weight of the equipment for a maximum of two (2) workers, thus 265 lb (120 kg).
- For extensions longer than 13'-4" (4,0 m), the first extension section must be a « tapered » section (universal or standard tapered with adapter).
- The intermediate extension section of 5'-0" (1,5 m) may be replaced by two sections of 2'-6" (0,75 m) for the 20K.
- It is **forbidden** to load on work and circulatory areas. These areas are reserved for workers and tools only.
- **Important!** The anti-pivot system wheels must be installed on both sides of the platform if one (1) or both (2) sides of the platform measure more than 23'-4" (7,10 m).  
SEE INSTALLING ANTI-PIVOT DEVICE, SMALL WHEEL (OPTIONAL), ON PAGE 97  
SEE INSTALLING ANTI-PIVOT DEVICE, LARGE WHEEL (OPTIONAL), ON PAGE 98

□	Installation allowed
A / B	Installation allowed with a 50% load reduction on the indicated side
X	Installation prohibited



Legend 1 - Loads distribution

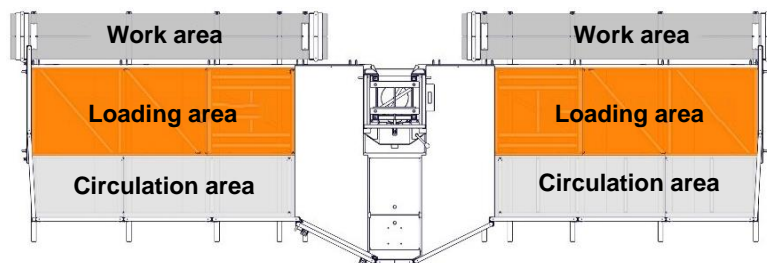
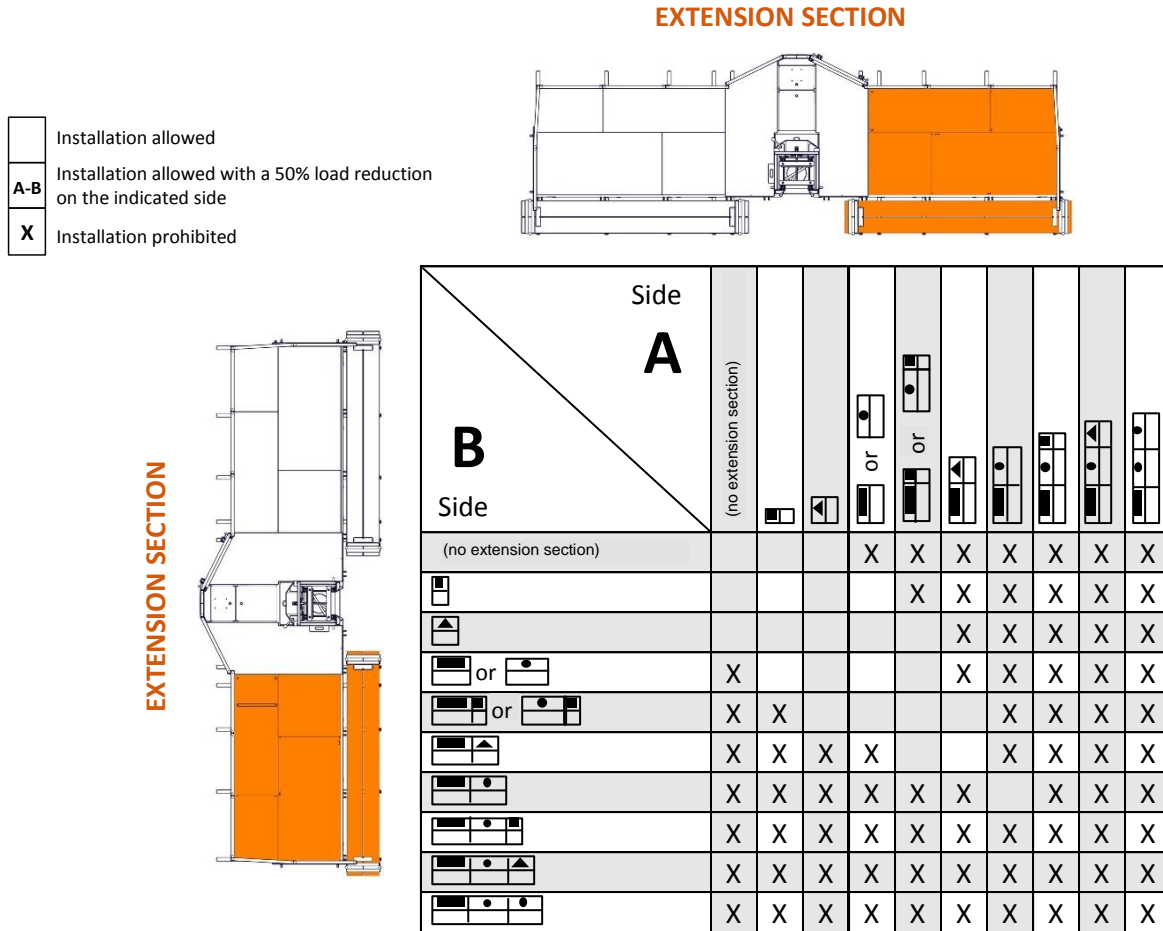


Figure 17 - Platform areas

## Configuration – Single-mast

Table 3 – Single-mast, loads distribution (masonry configuration)



- Full load (only):**
- 5 000 lb (2 268 kg) MAX per platform sides
  - Platform total 10 000 lb (4 536 kg) MAX

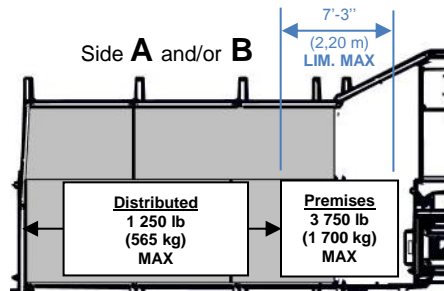
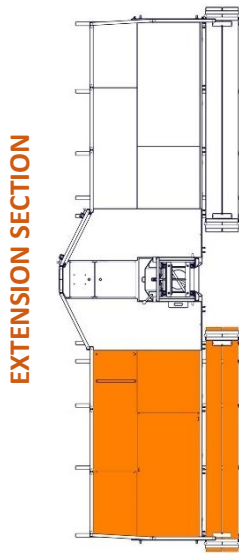
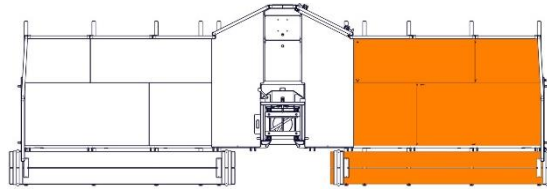


Figure 18 - Single-mast, full masonry load

Table 4 – Single-mast, loads distribution (typical configuration)

**EXTENSION SECTION**

	Installation allowed
A-B	Installation allowed with a 50% load reduction on the indicated side
X	Installation prohibited



<b>Side A</b>  <b>Side B</b>	(no extension section)	(no extension section)	(no extension section)	(no extension section)	(no extension section)	(no extension section)	(no extension section)	(no extension section)	(no extension section)
	(no extension section)	(no extension section)	(no extension section)	(no extension section)	(no extension section)	(no extension section)	(no extension section)	(no extension section)	(no extension section)
(no extension section)			X	X	X	X	X	X	X
(no extension section)			A	A	X	X	X	X	X
(no extension section)			A	A	X	X	X	X	X
(no extension section)	X	B			A	X	X	X	X
(no extension section)	X	B	B			A	X	X	X
(no extension section)	X	X	B	B		A	A	X	X
(no extension section)	X	X	X	X	B	B		A	X
(no extension section)	X	X	X	X	X	X	B		A
(no extension section)	X	X	X	X	X	X	X	B	A-B

**Fill load:**

- 5 000 lb (2 268 kg) MAX per platform sides
- Platform total 10 000 lb (4 536 kg) MAX

**Reduced load:**

**CASE 1 – Reduced load on one (1) side only**

- 2 500 lb (1 135 kg) MAX on the reduced load side
- 5 000 lb (2 268 kg) MAX on the full load side
- Platform total 7 500 lb (3 400 kg) MAX

**CASE 1 – Reduced load on the two (2) sides**

- 2 500 lb (1 135 kg) MAX on the reduced load sides
- Platform total 5 000 lb (2 268 kg) MAX

Side **A** and/or **B**

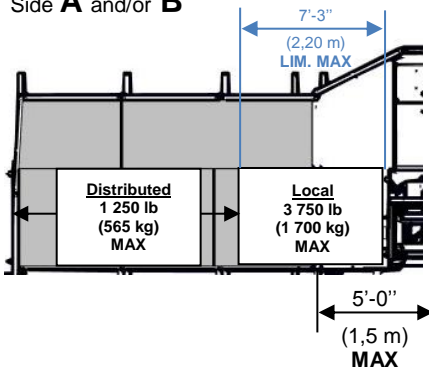


Figure 20 - Single-mast, typical full load

Side **A** and/or **B**

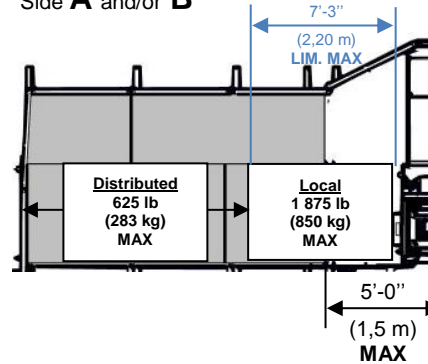


Figure 19 - Single-mast, typical reduced load

### Configuration example (single-mast)

The following is an example to help you understand how to use the configuration tables to install a single-mast:

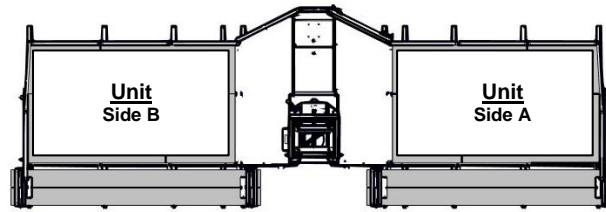


Figure 21 - Example, distribution zones per unit (single-mast)

Table 5 - Distribution example (single-mast, long extensions configuration)

EXTENSION SECTION

		Side A										
		(no extension section)										
Side B	(no extension section)				X	X	X	X	X	X	X	X
				A	A	X	X	X	X	X	X	
				A	A	X	X	X	X	X	X	
		X	B			A	X	X	X	X	X	
		X	B	B					X	X	X	
		X	X	B	B				X	X	X	
		X	X	X	X	B	B		A	X	X	
		X	X	X	X	X	B	B		A	X	
		X	X	X	X	X	X	X	B		A	
		X	X	X	X	X	X	X	X	B	A-B	

Unit Side B

Unit Side A

**Note:** For any extension length greater than or equal to 23'-4" (7,1 m) on one side of the unit, an anti-pivot device must be installed on both sides of the unit.

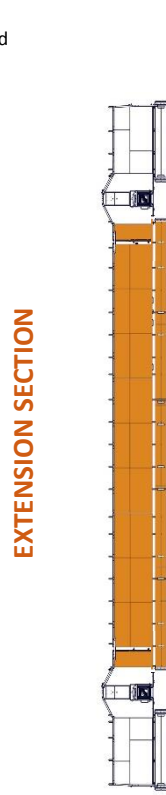
∞ SEE INSTALLING ANTI-PIVOT DEVICE, SMALL WHEEL (OPTIONAL) & INSTALLING ANTI-PIVOT DEVICE, LARGE WHEEL (OPTIONAL), ON PAGE 97 AND 98

## Configuration - Double mast

Table 6 – Double-mast, loads distribution (masonry configuration)

- Installation allowed
- A-B** Installation allowed with a 50% load reduction on the indicated side
- X** Installation prohibited

### EXTENSION SECTION



Side B Side A	Side A	(no extension section)									
	(*)	X					X	X	X	X	X
		X					X	X	X	X	X
		X					X	X	X	X	X
	(*)	X					X	X	X	X	X
		X					X	X	X	X	X
		X						X	X	X	X
	(*)	X					X	X	X	X	X
		X	X	X				X	X	X	X
		X	X	X	X	X			X	X	X
	(*)	X	X	X	X	X		X	X	X	X
		X	X	X	X	X	X	X	X	X	X

\* adapter required [20491501]

Full charge on the entire platform: 20 000 lb (9 075 kg) – 2 masts total MAXIMUM

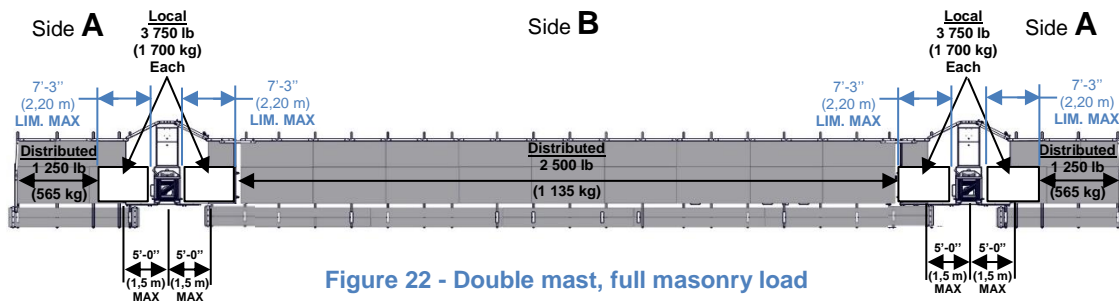


Figure 22 - Double mast, full masonry load

Table 7 – Double-mast, loads distribution (typical configuration)

- Installation allowed
- A-B Installation allowed with a 50% load reduction on the indicated side
- X Installation prohibited

**EXTENSION SECTION**

Side B Side A	Side	no extension section		or		or		or		or	
	20	40	60	20	40	60	20	40	60	20	40
(*)	X						A	X	X	X	X
	X						A	X	X	X	X
	X						A	X	X	X	X
(*)	X						A	X	X	X	X
	X						A	A	X	X	X
	X	B					A	X	X	X	X
(*)	X						A	A	X	X	X
	X	B					A	A	X	X	X
	X	X	B	B			A	X	X	X	X
(*)	X	X	B	B			A	A	X	X	X
	X	X	X	X	B	B			A	X	X

\* adapter required [20491501]

Full load on the entire platform: 20 000 lb (9 075 kg) total

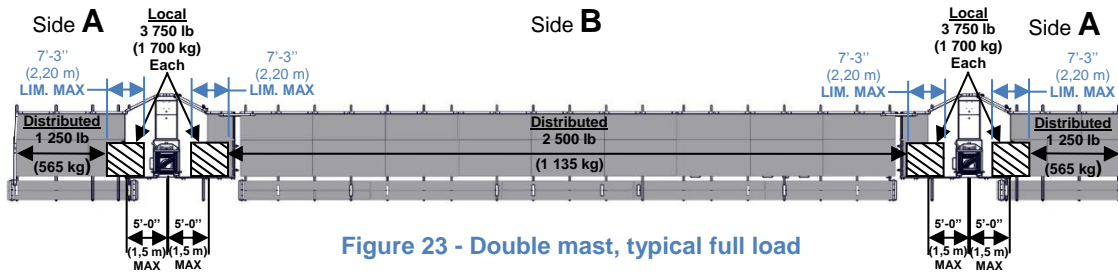


Figure 23 - Double mast, typical full load

Reduced load side A & B on the entire platform: 10 000 lb (4 535 kg) total

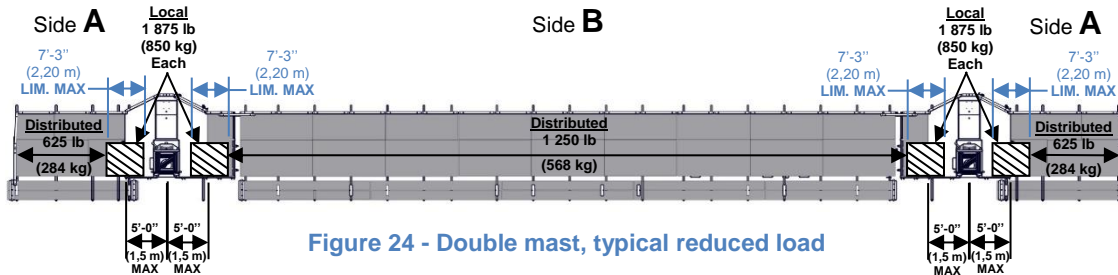


Figure 24 - Double mast, typical reduced load



### Configuration example (Double mast, typical configuration)

The following is an example to help you understand how to use the configuration tables. At first, in the double-mast configuration, each lifting unit is considered independently of the other within the table. In a second step, the load distributions are combined to obtain the total allowable distribution of the unit. Thus, in the following example:

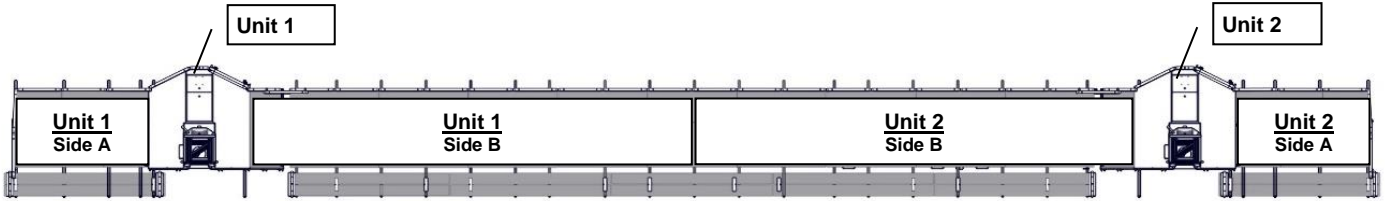


Figure 25 - Example, distribution zones per unit

Table 8 - Example of double mast distribution

EXTENSION SECTION		EXTENSION SECTION	
Unit 1		Unit 2	
Side A	Side B	Side A	Side B
(no extension section)	(no extension section)	(no extension section)	(no extension section)
20	(*) X	X	A X X X X
40	X	X	A X X X X
60	X	X	A X X X X
20	(*) X	X	A X X X X
40	X	X	A X X X X
60	X	B	A X X X X
20 or 40	(*) X	X	A A X X X
40 or 60	X	B	A A X X
20 or 40 or 60	X X B B	B	A X X
20	(*) X X B B	B	A A X X
40	X X X X B B	B	A X

\* Adapter required [20491501]

Note: For the bridge load distribution, always take the most restrictive configuration of the two platforms. Which is why the distribution on the central bridge is 1 250 lb (567 kg)-(half-load of units 1 & 2) and not 1 875 lb (850 kg)-(full load of unit 1 + half-load of unit 2).

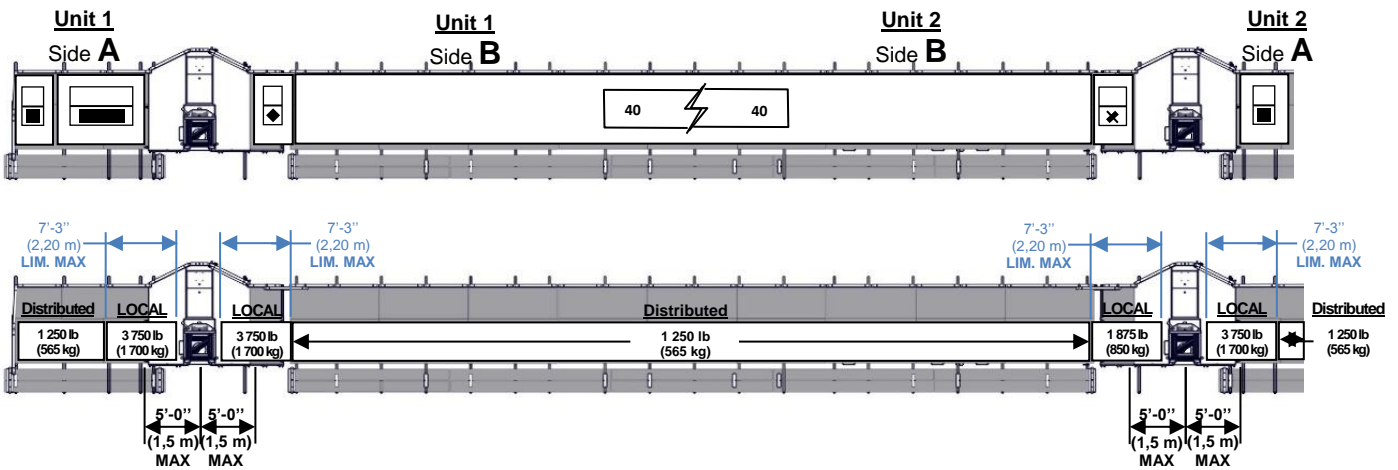


Figure 26-Example of load distribution

## Operation, use of the lifting unit



The operator must hold a valid **Level 1 Card**. This person must be familiar with the instructions for use, have sufficient experience and be aware of the risks involved in operating the platform.

- **IMPORTANT:** Refer to the section **WARNINGS** for general safety instructions and additional warnings.  
∞SEE **WARNINGS**, ON PAGE 6
- **IMPORTANT:** Before use at the beginning of each shift, all points of the **DAILY INSPECTION GRID** must be checked, including a functional check. When using the platform, the operator must strictly follow all operating instructions.  
∞SEE **DAILY INSPECTION GRID**, ON PAGE 155
- Make sure no one is under the platform or within the safety perimeter. Sufficient lighting must be available to ensure safe use. Notify all persons on the platform before performing any vertical movement of the platform. Beware of the presence of unauthorized persons.
- Before and during use of the platform, the operator must check for wind and unfavourable weather conditions. The platform must not be used if the wind speed exceeds the allowable limits or in the event of an electrical storm. For unfavourable wind speeds, consult the **TABLE 2- TECHNICAL SPECIFICATIONS**.  
∞SEE **GENERAL TECHNICAL SPECIFICATIONS**, ON PAGE 17
- Always use safety harnesses when handling planking and/or guardrails when passing a mast anchor or obstacles.  
∞SEE **REGULATORY ATTACHMENT POINTS**, ON PAGE 9
- The outrigger areas must be composed of FRACO outriggers and wooden planking in compliance with applicable local regulations. Any additions must be deducted from the allowable load. Any significant addition to the outriggers (steel plate, extra planking thickness, plywood or other ...) must be verified, approved and deducted from the allowable load by a competent person.  
∞SEE **PERMITTED CONFIGURATIONS AND LOAD DISTRIBUTION**, ON PAGE 18
- The operator must at all times ensure that load distributions and maximum number of people on the platform are respected. A maximum of two (2) persons per unit side must be considered, plus one (1) person operating the unit. This means a maximum of five (5) persons distributed over the entire platform surface for a single-mast assembly and ten (10) persons for a double-mast assembly. Refer to the information signs present on the platform. For a distribution with a higher number of workers, contact the FRACO Engineering Department.  
∞SEE, **PERMITTED CONFIGURATIONS AND LOAD DISTRIBUTION**, ON PAGE 18
- All loads likely to slip or fall from the platform must be secured. Keep the platform free of debris, rubbish, snow, etc. Make sure that no tools or other objects extend beyond the outer perimeter of the platform limited by the planking and guardrails. You can stop operation at any time by pressing the **EMERGENCY STOP** button (see **Figure 27** and **Figure 28** ON PAGE 28). In the event of breakage or malfunction, secure the platform.  
∞SEE **ASSISTANCE**, ON PAGE 157 and contact FRACO if the problem persists.
- When the platform is stopped after a vertical movement, make sure that it rests on the safety system. At the end of each shift or end of day, the platform must be placed in the « out of service » position and secured to prevent any unauthorized use. The platform shall be deemed to be in the « out of service » position when it is at an equal distance between two mast anchors and the loads on either side of the mast are balanced, or when the platform is lowered to the ground level.  
∞SEE **EMERGENCY STOP AND DESCENT PROCEDURE**, ON PAGE 31
- Prevent any unauthorized access to the platform. At the end of each shift, or during breaks, remove the key from the control panel. If required, padlock the access (refer to the applicable local regulations).
- If available, read the evacuation plan and its location before using the lifting unit.

## Using the Lifting unit (electric)

**Important!** Wait for complete engine cooling before filling the oil and gas tanks.  
Make sure you have completed your daily inspection before starting the engine.

∞ SEE DAILY INSPECTION GRID, ON PAGE 155

### Step 1 (Before engine start)

- 1- Make sure that the platform path is clear of obstacles.
- 2- Make sure the « emergency stop button » (see [Figure 27](#)) is released.
- 3- Make sure that the « engine selector » (see [Figure 15](#) and [Figure 34](#)) is in the « FRSM-20K » position.  
\*If applicable, the selector is present on the control box on old models (see [Figure 28](#))
- 4- Make sure that the « crane lever » (see [Figure 32](#)) is in the « FRSM-20K » position.

### Check general engines condition (principal and emergency)

- 5- Remove any excessive dirt or debris, especially around the muffler and starters.
- 6- Visually inspect for damage.
- 7- Make sure all guards and covers are in place and in good condition. Also check that all nuts, bolts and screws are tight.
- 8- Check the air filter element. A dirty air filter element limits the air flow to the carburetor, which reduces engine performance.

### Step 2 (Ignition)

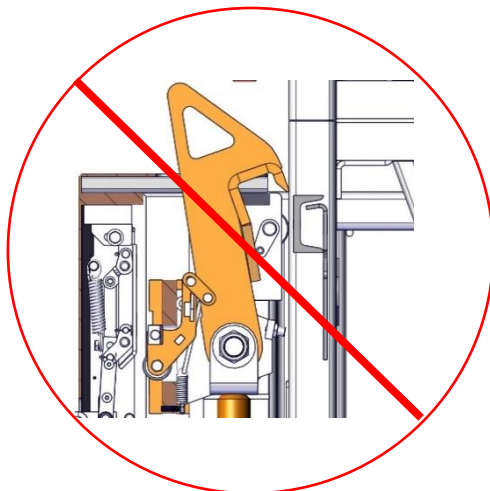
- 9- Make sure that the « Fuel valve lever » is in the « MARCHE/ON » position.
- 10- Make sure that the « Throttle lever » is in the « MAX » position.
- 11- Pull the « Choke knob » located above the « 20K panel » on the right of the unit (see [Figure 29](#)).
- 12- Turn the « CONTACT » key (see [Figure 27](#)) to the « START » position.
- 13- When the engine is started, let the key return to the « MARCHE/ON » position.
- 14- Push the « choke knob ».

### Step 3 (Raising the platform)

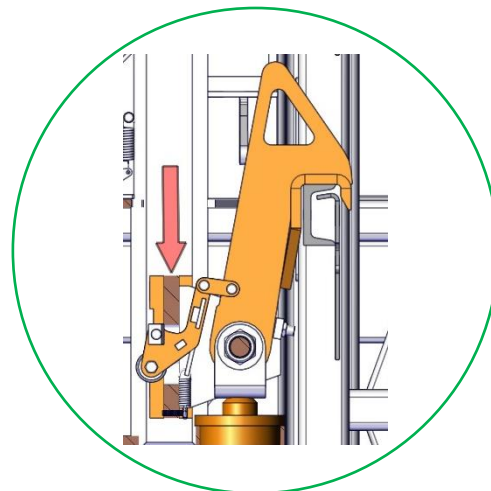
- 15- Press the « 20K activation pedal » and push it to the « UP » position (see [Figure 31](#)).
- 16- Turn the « 20K operation pivot » (see [Figure 30](#)) clockwise to open the cylinder.
- 17- When the « 20K hook » reaches the bar, the cylinder is fully open. Turn the « 20K operation pivot » counter clockwise to close the cylinder. First, the « 20K hook » rests on the bar and second, the platform is raised until this cylinder is fully closed (see [Figure 36](#), [Figure 37](#) and [Figure 38](#)).

**Important!** Do a visual scan to ensure that the hook is properly engaged on a bar of the mast as illustrated below.

- 18- When the cylinder is fully closed, turn the « 20K operation pivot » clockwise to open the cylinder and to disengage the « 20K hook » (see [Figure 38](#)). The lifting unit will be supported on safety devices.
- 19- Repeat steps 18 to 21 until the desired height has been reached.



Disengaged hook



Properly engaged hook

## Using the lifting unit (descent)

### Step 1 (Before engine start)

- 1- Make sure that the platform path is clear of obstacles.
- 2- Make sure the « emergency stop button » (see [Figure 27](#)) is in released position.
- 3- Make sure that the « engine selector » (see [Figure 15](#) and [Figure 34](#)) is in the « FRSM-20K » position.  
\*If applicable, the selector is present on the control box on older models (see [Figure 28](#))
- 4- Make sure that the « crane selector » (see [Figure 32](#)) is in the « FRSM-20K » position.

### Step 2 (Ignition)

- 5- Make sure that the « Gas valve lever » is in the « MARCHE/ON » position.
- 6- Make sure that the « Throttle lever » is in the « MAX » position.
- 7- Pull the « choke knob » (see [Figure 29](#)) located above the « 20K pedal » on the right side of the unit.
- 8- Turn the « CONTACT » key (see [Figure 27](#)) to the « START » position.
- 9- When the engine is started, let the key return to the « CONTACT » position.
- 10- Push the « choke knob ».

### Step 3 (Lowering the platform)

- 11- Kick the « Latch » (see [Figure 31](#) and [Figure 39](#)) to activate the « DOWN » position
- 12- Turn the « 20K operation pivot » (see [Figure 30](#)) counterclockwise to raise the platform until the cylinder is fully closed (see [Figure 40](#)).
- 13- When the cylinder is fully closed, press the « 20K Pedal » and turn the « 20K operation pivot » clockwise to open the cylinder. The platform starts to descend (see [Figure 41](#)).
- 14- Keep the « 20K Operation Pivot » clockwise (see) and your foot on the « 20K Pedal » (see [Figure 41](#)) until you feel a slight pressure on the pedal under your foot indicating that you must release the pedal. The lifting unit will be supported on safety devices. This will disengage the « 20K Hook ».
- 15- Repeat steps 12 to 14 until the desired height has been reached.

Note: It is recommended to leave the unit supported on its safety devices and close the cylinder when the work height has been reached. This will prevent the cylinder from deteriorating prematurely.

### Important!

-A visual inspection of all the points in the daily inspection grid shall be done at each shift.

∞SEE DAILY INSPECTION GRID, ON PAGE 155

-You can press the « emergency stop button » at any time (see [Figure 27](#)). The platform will stop automatically.

-If the main engine does not start or for any mechanical problem, kindly refer to the troubleshooting table in the appendix.

∞SEE ASSISTANCE, ON PAGE 157

-The emergency engine must be started and tested throughout the verification period of the daily inspection grid.

-Do not fill the engine when it is hot! Let the engine cool before filling it.

-Do not fill the gas tank too much.

## Control panel

<p style="text-align: center;"><b>Figure 27 - FRSM-20K control box</b></p>	<p>Valid control box for 20K lifting unit models (gas, diesel)</p> <p>For the recent lifting unit models, the engine selector is accessible under the engine access panel at the location indicated by the sticker in <a href="#">Figure 15</a> ON PAGE 15 .</p> <ol style="list-style-type: none"> <li>1. <b>Emergency stop button</b></li> <li>2. Key starter</li> <li>3. Inclinometer sound alarm</li> <li>4. Hour meter</li> </ol>
<p style="text-align: center;"><b>Figure 28 - Old FRSM-20K control box (REFERENCE)</b></p>	<p>Some first-generation machines are equipped with a boiler on which an engine selector is found.</p> <ol style="list-style-type: none"> <li>5. Engine selector</li> </ol>

## Using the lifting unit (list of figures)

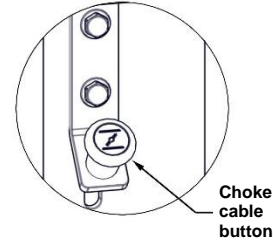
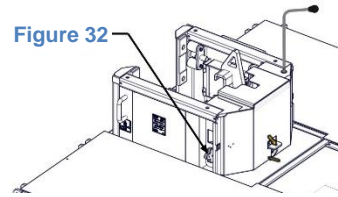
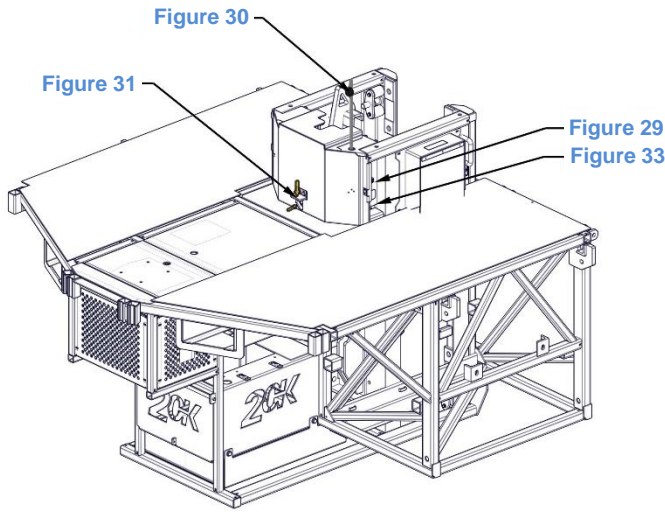


Figure 29

Operation pivot  
Clockwise: Opening the hydraulic cylinder

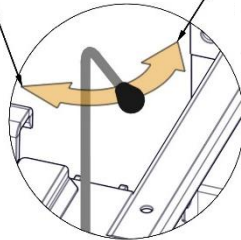


Figure 30

Operation pivot  
Counterclockwise: Closing the hydraulic cylinder

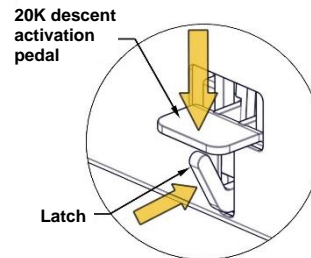


Figure 31

Crane selector

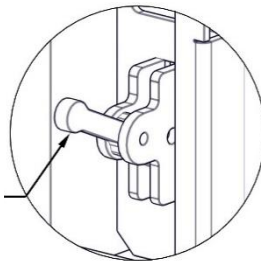


Figure 32

20K lock system pedal

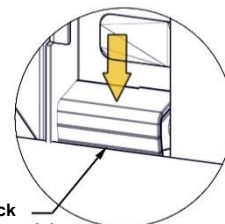


Figure 33

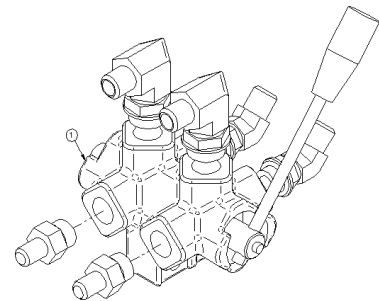


Figure 34

## Using the inclinometer (if applicable\*)

### Inclinometer sound alarm (See Figure 27):

In the double mast configuration, when bridge inclination between the two units exceeds the permitted safety value of  $\pm 3^\circ$ , the alarm is triggered. In that case, you must stop using the unit and reduce this level difference by lowering or raising one of the lifting units. When the inclination exceeds  $5^\circ$ , the platform stops. **You are then in an emergency situation!**

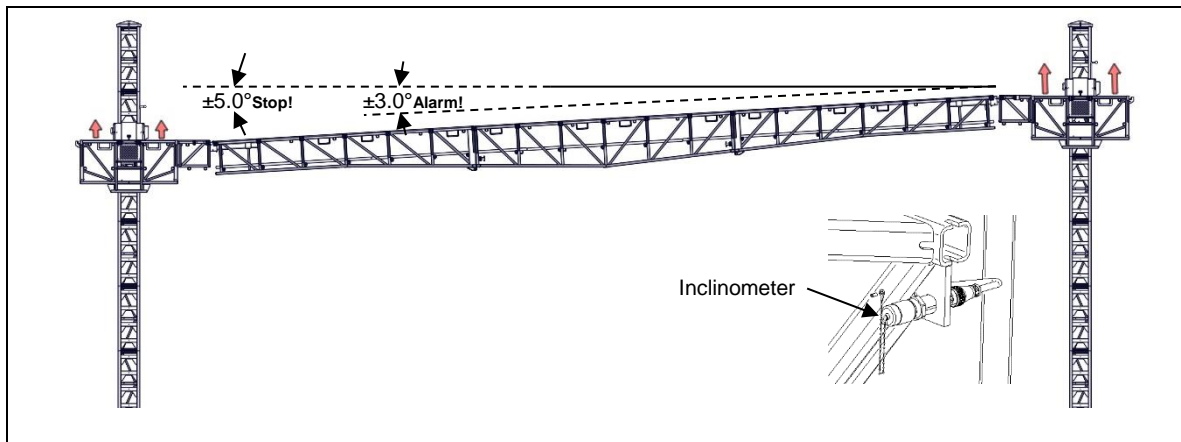
Use the emergency descent to lower the highest lifting unit.

∞ SEE EMERGENCY STOP AND DESCENT PROCEDURE, ON PAGE 31

Once the angle of the platform is again within the admissible  $\pm 3^\circ$  limits, normal operation is again possible.

∞ SEE EMERGENCY STOP AND DESCENT PROCEDURE, ON PAGE 31

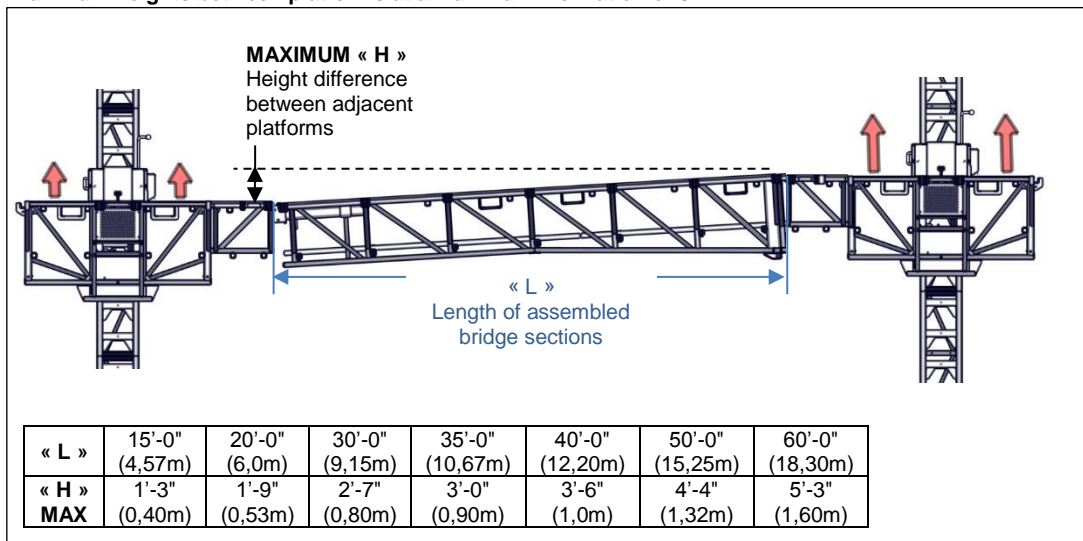
For older generation machines, make sure that the emergency descent release lever is returned to its initial position (facing down) after the platforms have been levelled.



\*Note: The use of the inclinometer is mandatory in Europe. Elsewhere, comply with the applicable local regulations.

Figure 35 - Inclinometer

### Maximum heights between platforms at a maximum inclination of $5^\circ$



## Emergency stop and descent procedure

The « **Emergency stop button** » (see [Figure 27](#)) may be used at any time when the operator deems that the situation warrants it.

### Step 1 (Before engine start)

- 1- Make sure that the platform path is clear of obstacles.
- 2- Make sure that the « Crane selector » (see [Figure 32](#)) is in the « FRSM-20K » position.
- 3- Make sure that the « Valve Selector » (see [Figure 28](#) & [Figure 34](#)) is in the « Emergency » position, thus selecting the emergency engine.

### Step 2 (Ignition)

- 4- Make sure that the « Fuel valve lever » is in the « MARCHE/ON » position.
- 5- Place the engine selector lever in the « Emergency » position (see [Figure 15](#) and [Figure 34](#)).  
\*The old lifting unit models may be equipped with an « Engine Selector » on the control box (see [Figure 28](#)). In this case ensure that the « Engine Selector » is in the « FRSM 20K » position and the « Valve Selector » (see [Figure 15](#) and [Figure 34](#)) is in the « Emergency » position.
- 6- Place the engine booster choke lever in the « CLOSED » position to enable start-up.
- 7- Place the engine booster gas lever in the « MAX » position.
- 8- Start the engine by pulling on the starter handle. Pull gently until resistance is felt and then pull sharply. Gently return the handle to its neutral position. Avoid letting the handle go back against the engine to protect the equipment.
- 9- Gradually return the choke lever to the « OPEN » position after the engine has heated up for a few minutes.  
\* For more information, consult the engine booster manual provided with the documentation.

### Step 3 (Lowering the platform)

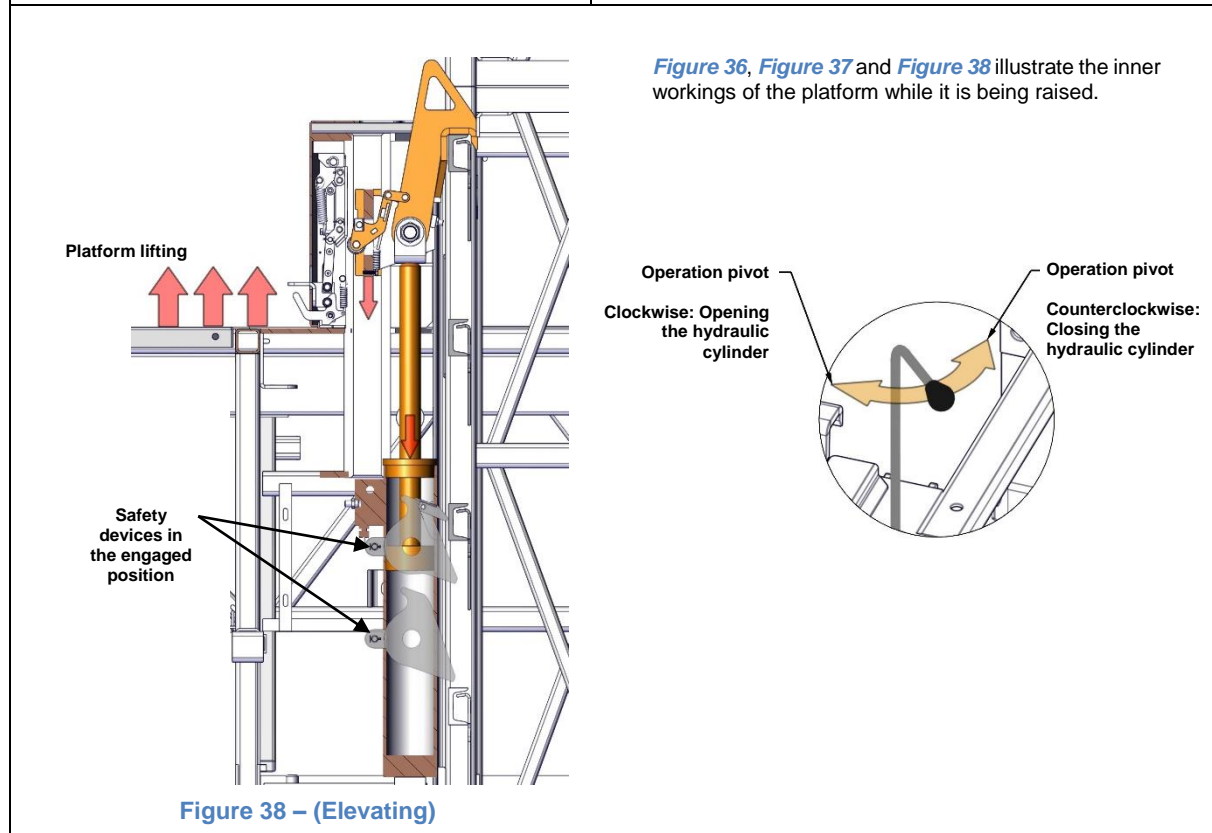
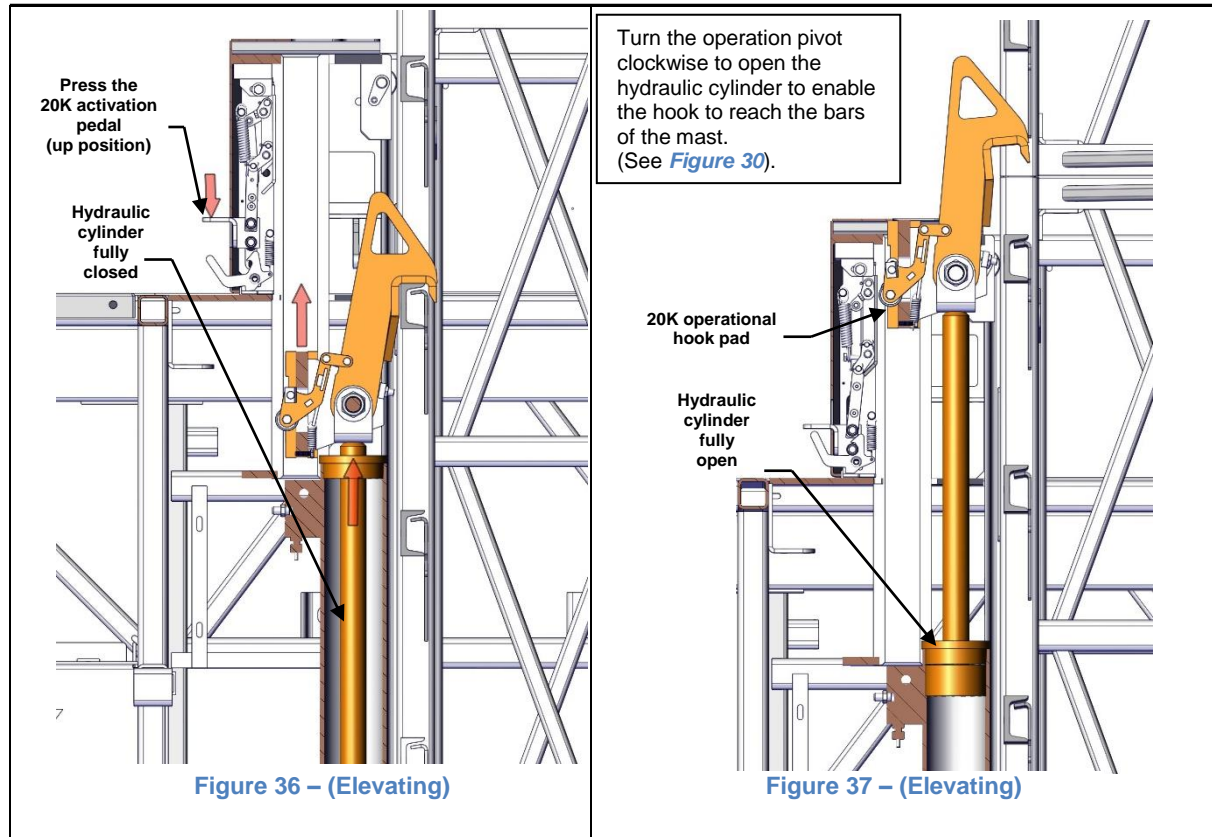
- 10- Kick the « Latch » (see [Figure 31](#) AND [Figure 39](#)) to activate the « DOWN » position
- 11- Turn the « 20K operation pivot » (see [Figure 30](#)) counterclockwise to raise the platform until the cylinder is fully closed (see [Figure 40](#)).
- 12- When the cylinder is fully closed, press the « 20K Pedal » and turn the « 20K operation pivot » clockwise to open the cylinder. The platform starts to descend (see [Figure 41](#)).
- 13- Keep the « 20K Operation Pivot » clockwise (see [Figure 30](#)) and your foot on the « 20K Pedal » (see [Figure 41](#)) until you feel a slight pressure on the pedal under your foot indicating that you must release the pedal. The lifting unit will be supported on safety devices. This will disengage the « 20K Hook ».

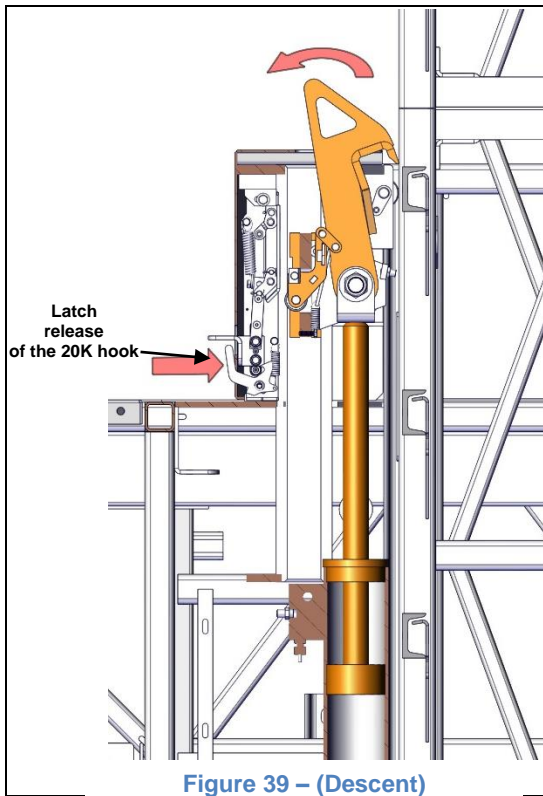
### Step 4 (SHUTTING DOWN the engine)

For a simple shutdown proceed as specified in the Honda engine booster manual provided in the documentation. To shut down the engine booster in case of an emergency, simply place the « Engine Selector » of the 20K control box to the « OFF » position.

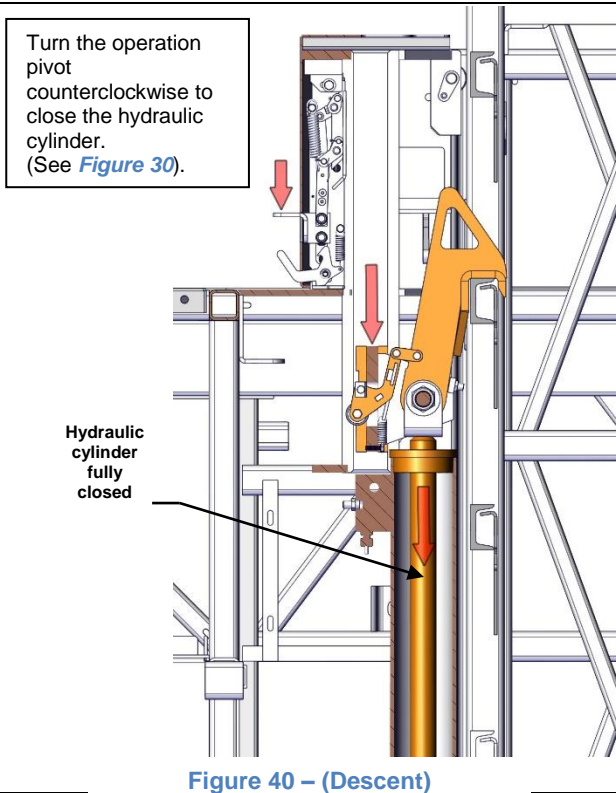


## Using and operating the Lifting unit

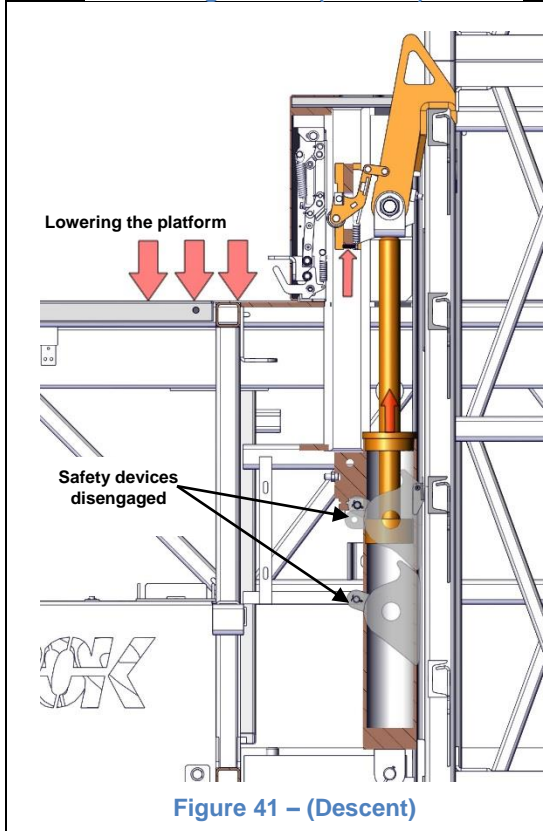




**Figure 39 – (Descent)**

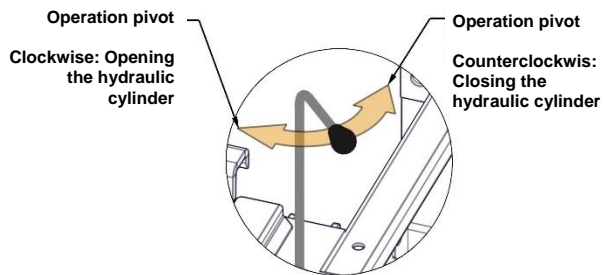


**Figure 40 – (Descent)**



**Figure 41 – (Descent)**

Figure 39, Figure 40 and Figure 41 illustrate the inner workings of the platform while it is being lowered.



## Chapter B – Lifting Unit and Bases

### Ground load and load distribution

The total load of the equipment is transmitted to the ground by the base. Ensure that the floor is stable and has the necessary carrying capacity for the installation.

∞SEE TABLE 9 ON PAGE 34, TABLE 10 ON PAGE 35, TABLE 11 ON PAGE 36

The entire surface base or shims must be in contact with the foundation. The floor must be free of holes or trenches, well drained or raised to avoid any water buildup.

Ensure that no excavation work is planned during installation or use of the platform.

For a **ground base**, level the ground with crushed stones as foundation, 4" to 6" (100 mm to 150 mm) thick and exceeding the ground base dimensions by 4" (100 mm) using 0-3/4" (19mm) crushed stone.

∞SEE TABLE 9 - GROUND LOAD, GROUND BASE, ON PAGE 34

For **freestanding bases**, install shims that exceed the dimensions of the base feet to prevent the feet from sinking into the ground.

∞SEE FIGURE 42 - LOAD DISTRIBUTION, UNIVERSAL FREESTANDING BASE, ON PAGE 35

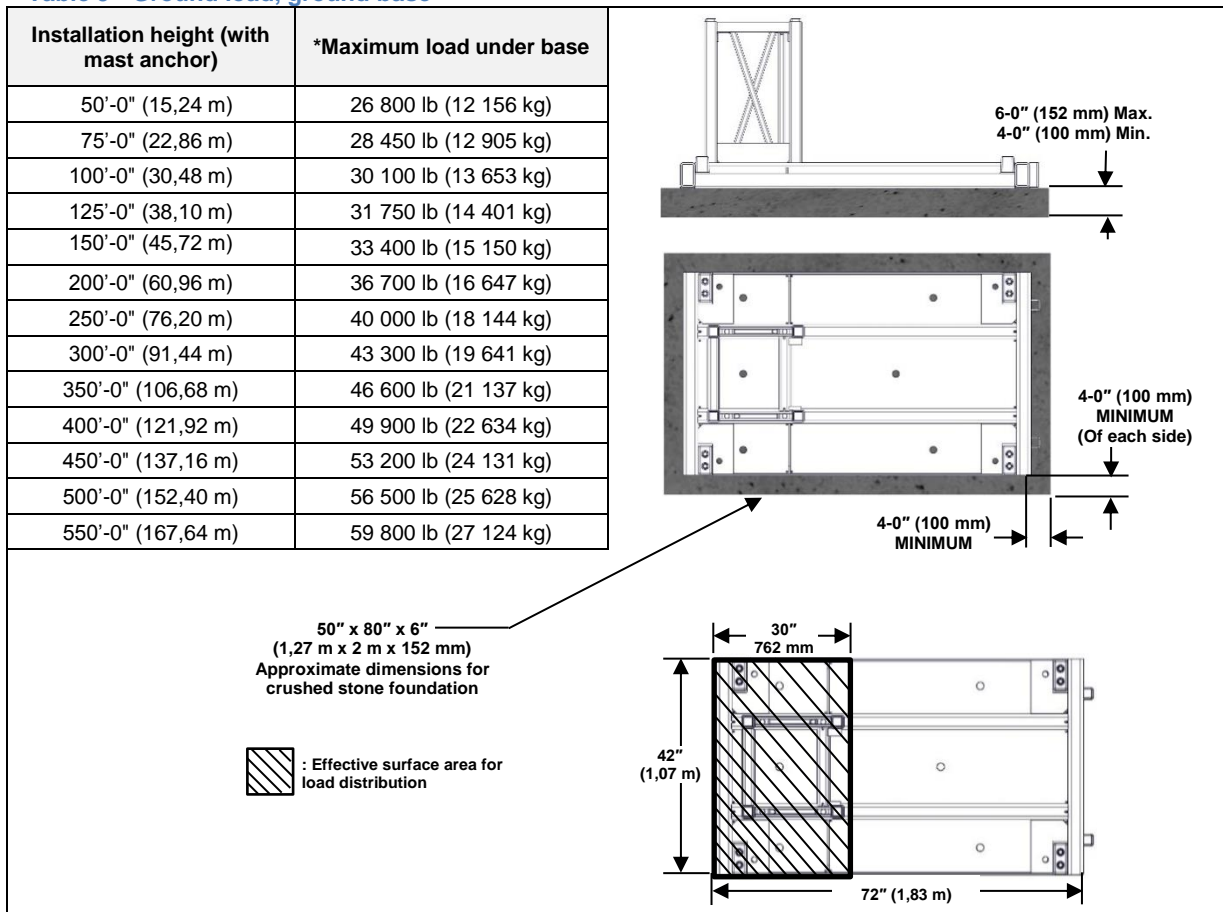
∞SEE FIGURE 43 - LOAD DISTRIBUTION, 20K FREESTANDING BASE, ON PAGE 36

### Ground load and maximum height

The following tables show the loads transmitted from the base to the ground. These loads do not include the safety/dynamic factors that must be taken into account in accordance with the applicable local regulations.

### Ground load - Ground base (14030019)

Table 9 - Ground load, ground base



### Ground load - Universal freestanding base (14030109)

Note: The universal freestanding base must be combined with a ground base (14030019) or a bolted base for mast (14030110) assembled on top of the freestanding base.

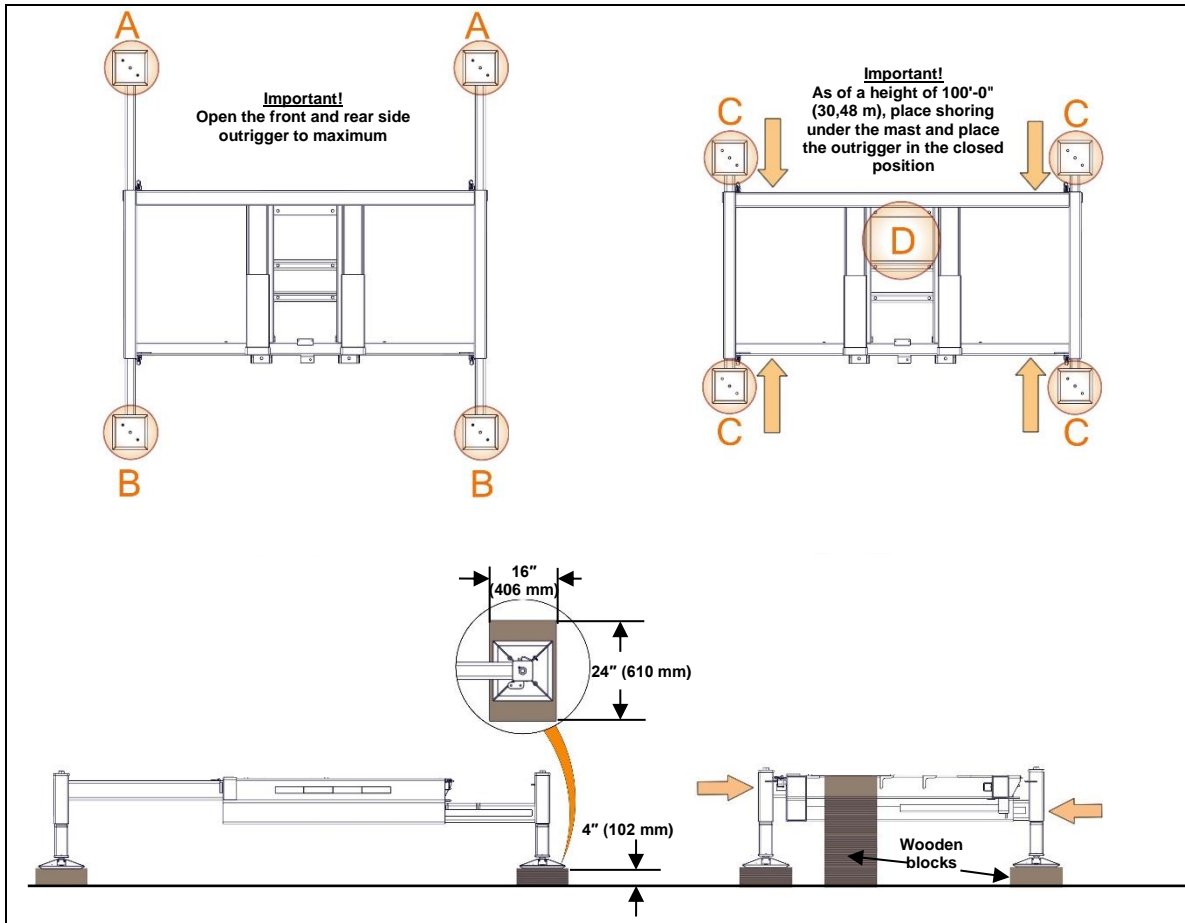


Figure 42 - Load distribution, universal freestanding base

Table 10 - Ground load, universal freestanding base

Freestanding installation height	**Maximum load under base (at targeted locations)	
45'-0" (13,72 m)	A = 14 200 lb (6 441 kg) per stand	B = 11 500 lb (5 216 kg) per stand
Installation height	**Maximum load under base	
50'-0" (15,24 m)	A = 12 100 lb (5 488 kg) per stand	B = 11 500 lb (5 216 kg) per stand
75'-0" (22,86 m)	A = 12 550 lb (5 693 kg) per stand	B = 9 750 lb (4 422 kg) per stand
100'-0" (30,48 m)	A = 12 950 lb (5 875 kg) per stand	B = 10 050 lb (4 559 kg) per stand
Installation height	**Maximum load under base	
100'-0" (30,48 m)*	C = 3 500 lb (1 590 kg) per stand	D = 33 400 lb (15 150 kg) under the mast
125'-0" (38,10 m)*	C = 3 500 lb (1 590 kg) per stand	D = 34 650 lb (15 717 kg) under the mast
150'-0" (45,72 m)*	C = 3 500 lb (1 590 kg) per stand	D = 35 900 lb (16 284 kg) under the mast
200'-0" (60,96 m)*	C = 3 500 lb (1 590 kg) per stand	D = 38 400 lb (17 418 kg) under the mast
Over 200'-0" (60,96 m)	NOT ALLOWED	

\*\* For an installation over 100'-0" (30,48 m), it is necessary to place shoring directly under the mast and drive the outriggers back in up to the closed position.

\*\*The following loads are not factored.

∞REFER TO SECTION DIMENSIONS WITH FREESTANDING BASE (UNIVERSAL, 20K), ON PAGE 11

### Ground load - Universal freestanding base (14030053)

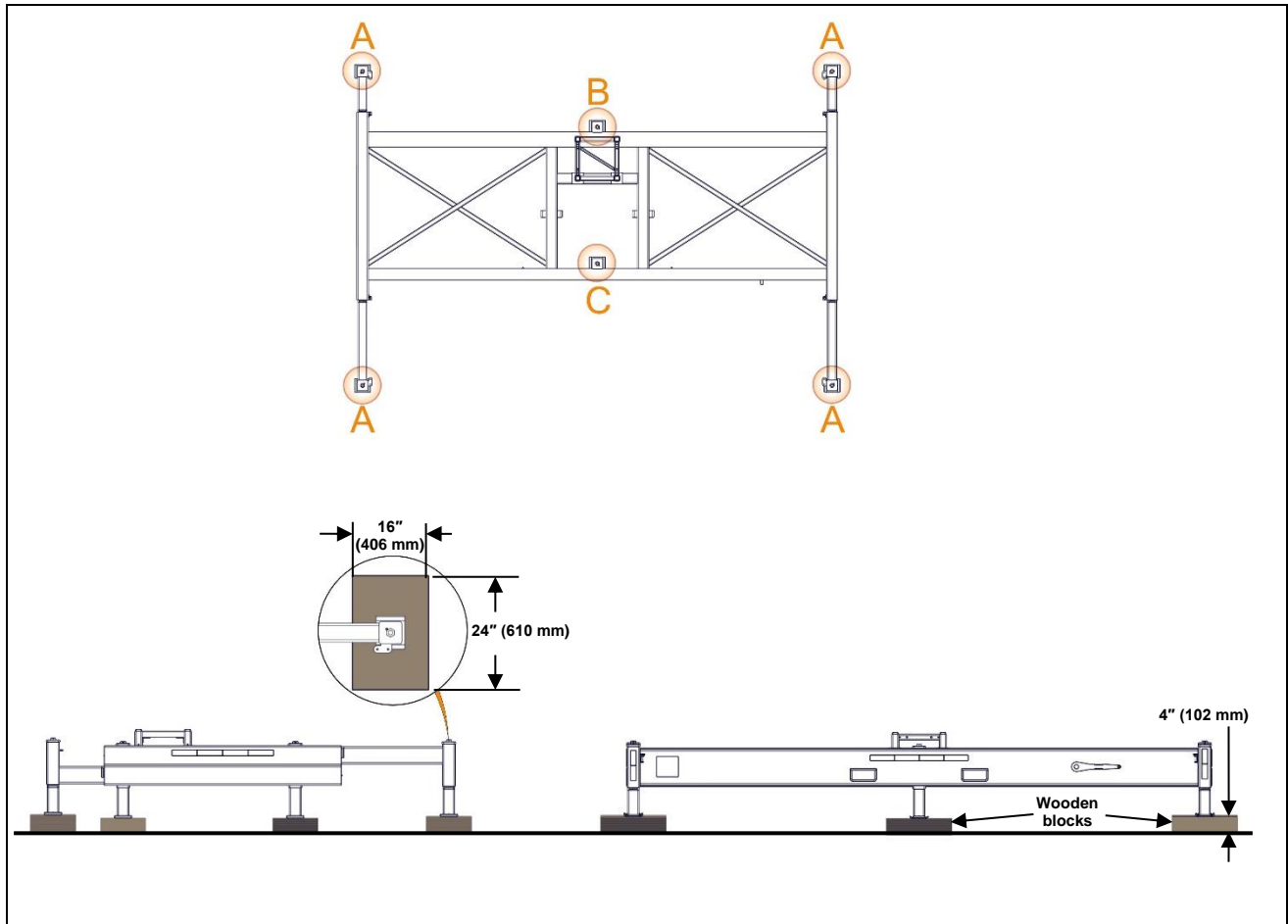


Figure 43 - Load distribution, 20K freestanding base

Table 11 - Ground load, 20K freestanding base

Installation height	Maximum load under base*		
40'-0" (13,72 m) <b>[Freestanding]</b>	A = 3 500 lb (1 590 kg) per stand	B = 22 800 lb (10 342 kg) per stand	C = 7 600 lb (3 447 kg) per stand
75'-0" (22,86 m)	A = 3 500 lb (1 590 kg) per stand	B = 24 150 lb (10 955 kg) per stand	C = 8 050 lb (3 652 kg) per stand
100'-0" (30,48 m)	A = 3 500 lb (1 590 kg) per stand	B = 25 050 lb (11 363 kg) per stand	C = 8 350 lb (3 788 kg) per stand
Over 100'-0" (30,48 m)	NOT ALLOWED		

\*The following loads are not factored.

°REFER TO SECTION DIMENSIONS WITH FREESTANDING BASE (UNIVERSAL, 20K), ON PAGE 11

## Chapter C – Installation and Dismantling

### Installation

The required equipment is determined according to the specific needs of the works to be carried out (surfaces to be covered, working methods, building relevant architectural details, presence of balconies, roofing, numbers of planks used, etc.) and the allowed configurations.

Such information is gathered during the identification of the installation site and must be the subject of a site plan and/or quote established by an engineer. Please refer to this page for specific details, if any.

To be performed upon receipt of the equipment and after on-site equipment unloading: ensure you have all the components required to carry out the installation and that the equipment received corresponds to the packing slip. Notify the transport provider of any damage found during the receipt verification, and notify your supervisor.

Make sure that you have the tools for proper assembly.

**Important!** Refer to the section **OPERATION, USE OF THE LIFTING UNIT** for instructions on using the platform before you begin.

∞SEE OPERATION, USE OF THE LIFTING UNIT, ON PAGE 25

**Important!** Tightening the bolts when assembling the various components must be done using a pneumatic or electric shock wrench. Regardless of the method used, it is imperative to **respect the tightening torques defined** at each step.

**Important!** Any installation, dismantling and displacement operation must be carried out by a certified installer (Level 2A or 2B).

**Important!** Always use a safety harness that is properly secured to an attachment point on the platform when assembling and dismantling the platform.

∞SEE REGULATORY REGULATORY attachment **points** ON PAGE 9

### Locating the installation site and taking measurements

Identify the building facade on which the platform will be installed.

### Safety perimeter

Determine a sufficient safety perimeter and prohibit access around the base, platform and any areas at risk around such area. This must be done in accordance with applicable local safety standards and regulations. No objects or debris should be stored in this perimeter.

### Taking measurements and identifying the location of the lifting unit

**NOTE:** The distance to the building will be determined based on the distance from the finished wall, the most distant point (balconies, window edges, gutters, roofs, etc.) and the number of planks placed on the outriggers used to perform the works.

Mark the exact location of the base of the unit on the ground. In case of a bridge configuration (double-mast or more), determine the exact position of each unit taking into account the distance between the masts.

∞SEE FIGURE 6 - CLEARANCE TO FINISHED WALLS AND AROUND THE UNITS, ON PAGE 12

∞SEE TABLE 1 - DIMENSIONS AND CLEARANCE, ON PAGE 13

∞SEE TABLE 17 - DISTANCE BETWEEN THE MASTS, ON PAGE 151

## Handling and lifting operation

### Lifting points

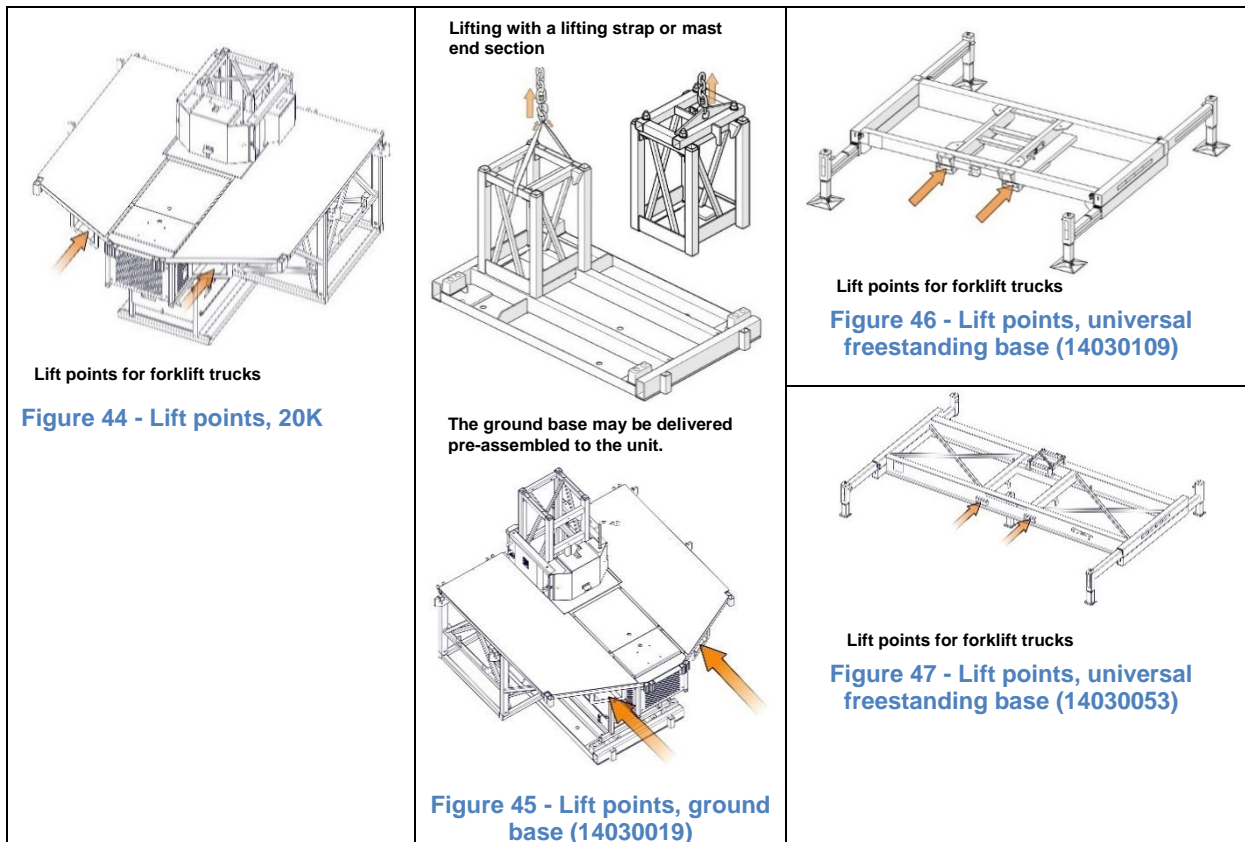
The various components of the platform can be loaded and unloaded using a forklift truck, crane truck or mobile crane, or a tower crane with sufficient capacity.

Some components such as the lifting unit, the bases or the bridge and extension sections have specific lifting points designed for the insertion of forklift forks.

Lifting straps can also be used to move the components.

The choice of lifting straps, their load capacity, layout, number and manner in which they are used to lift components is the responsibility of the operator of the lifting equipment. This person must also take into account the combined total weight of the handled components.

The operator must be adequately trained in the use of lifting equipment as defined in the applicable local regulations.



## Lifting, use of the mast end section

During lifting operations, the mast end section (13030029) and the mast sections (13030041) may only be moved as a **MAXIMUM** assembly section of 40'-0" (12,2 m). This limit eliminates the risk of the masts being bent during lifting and placement of equipment. The mast end section can lift a maximum load of 6 500 lb (2 950 kg). (*Figure 48*).

Bolt each section by applying a torque of 265 ft\*lb (360 N\*m).

**Note:** For all of the following explanations, the term « **mast sections** » means an individual part (13030018) and « **mast** » means an assembly of two (2) or more mast sections. The masts may be pre-assembled on the ground or erected one section at a time.

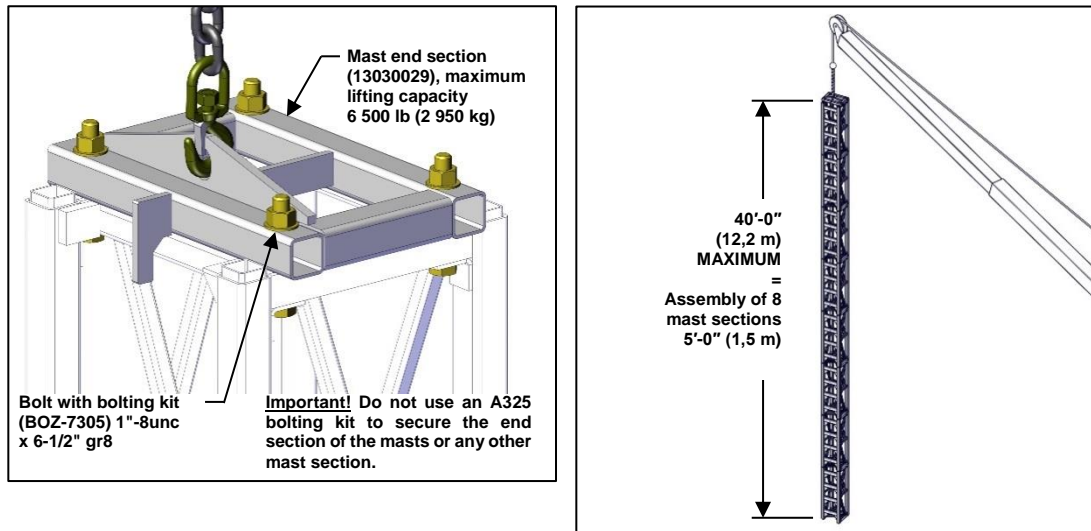


Figure 48 – Mast end section

## Use of lifting slings

- Mast end sections must be removed before positioning the slings or belts (*Figure 49*).
- Lifting operations of assemblies up to a **MAXIMUM** 15 000 lb (6 804 kg) may be carried out using slings (*Figure 50*).
- The assemblies shall have an equivalent load distribution on both (2) sides of the mast's centre of gravity.
- The responsibility for checking the weights of the assembled elements belongs to the person in charge of the lifting operations.
- Only a FRACO certified installer (Level 2A and 2B) may handle, assemble or dismantle FRACO equipment.
- Ensure that the lifting equipment used (cranes, slings, chains, belts, etc.) have the required lifting capacity.
- Ensure that the working methods used comply with applicable local laws and regulations.

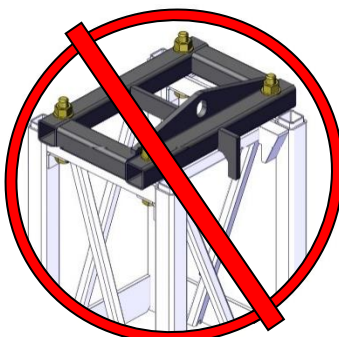


Figure 49

Lifting capacity of 15 000 lb (6 804 kg) **MAXIMUM**

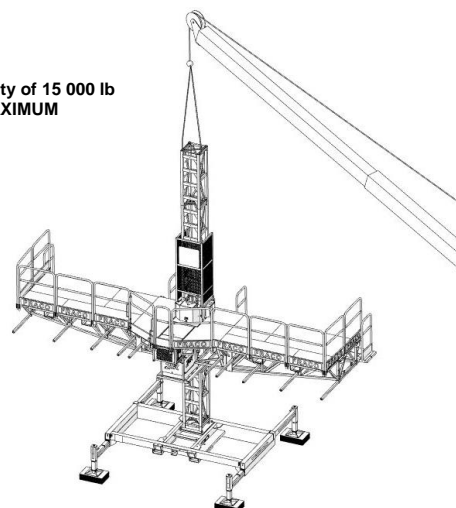


Figure 50



## Use of lifting slings (CONTINUED)

- Lifting belts and slings must be positioned on the side of the lifting bars for the 20K machine, in the corners marked by the bolt insertion holes (51).
- There must be a minimum distance of 8'-0" (2,44 m) between the end of the mast and the lifting hook must be observed (51).

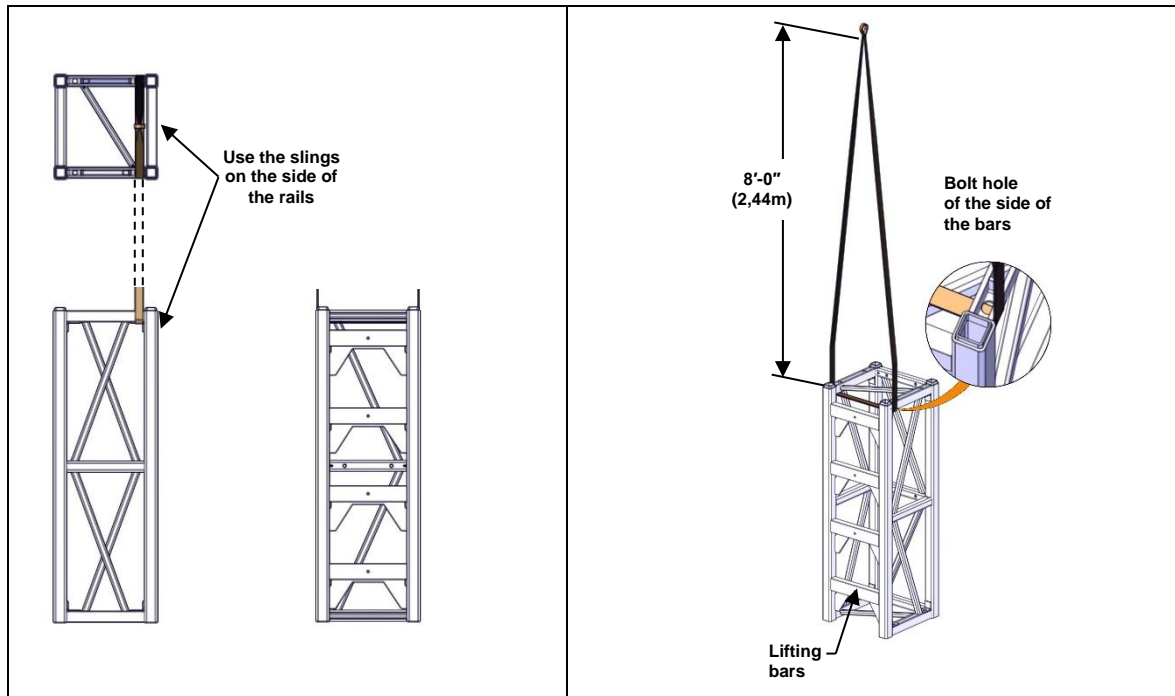


Figure 51 - Use of slings and belts

## Installing the base and lifting unit

### Installation with ground base (14030019)

**Figure 52 - Crushed stone foundation**

**Step 1** – Level the floor under the base with 4,0" (100 mm) to 6" (150 mm) of 0-3/4" crushed stone, respecting the dimensions defined in [Table 9, ON PAGE 34](#)

**Step 2** – Accurately mark the dimensions of the ground base on the crushed stone foundation with a minimum clearance of 4" (100 mm) all around it. Mark the centre in front of the foundation facing the wall.

**Step 3** – Check the levelling of the stone foundation using a spirit level and check its perpendicularity to the wall.

**Step 4** – Accurately measure the « N » distance between the centre mark and the finished wall. « N » = 21" (553 mm) min for a unit with two (2) plankings installed on its outriggers. « N » = 67" (1.702 mm) MAX.

∞SEE FIGURE 6 - CLEARANCE TO FINISHED WALLS AND AROUND THE UNITS, ON PAGE 12

∞SEE TABLE 1 - DIMENSIONS AND CLEARANCE, ON PAGE 13

**Step 5** – Position the unit perpendicular to the wall using a lifting device.

∞SEE INSTALLATION/DISMANTLING OF MAST SECTIONS, ON PAGE 73

**Step 6** – Check the vertical and horizontal levelling of the unit. It is important that the mast be perfectly perpendicular to the ground.

---

**Figure 53 - Unit installation on ground base**

« H »

Elevating unit

Spirit level -  
Horizontal levelling of the crushed stone foundation

Crushed stone foundation

Spirit level -  
Vertical levelling of the mast

« N »

## Installation with universal freestanding base (14030109)

**Step 1** – Pull the front and rear stabilizers of the base as far as possible and lower the legs of the stabilizers onto wooden blocks. It is important to respect the **MINIMUM** and **MAXIMUM** limits of opening stickers as shown in [Figure 136](#) ON PAGE 148. For installations over 100'-0" (30 m) high, retract the stabilizers in the closed position as shown in [Figure 42](#) and install shoring pads directly under the mast.

**Step 2** – Accurately measure the « H » distance between the mast and the anchor wall and confirm perpendicularity to the wall.

∞ SEE FIGURE 6 - CLEARANCE TO FINISHED WALLS AND AROUND THE UNITS, ON PAGE 12

∞ SEE TABLE 1 - DIMENSIONS AND CLEARANCE, ON PAGE 13

**Step 3** – Check that the mast is perfectly vertical using a spirit level. Check that the base (not the platform) is perfectly horizontal using a level. Ensure that the stabilizers are centered in the middle of the shoring pads. To level the base, use the hex wrench to adjust the stabilizer jacks.

**Step 4** – Install the bolted base (14030019) or the bolted base (14030110) directly on to the universal freestanding base (14030109) as shown in [Figure 55](#). Then, bolt the first mast section of the lifting unit (13030041) to the ground base (14030019) or the bolted base (14030110).

**Step 5** – Bolt a mast section (13030041) above the one already present in the unit. Lift the unit approximately 18" (460 mm) and bolt all the mast bolts with an impact wrench. Check that the mast is perfectly vertical using a level.

**Step 6** – Lower the unit to its lowest position and recheck general levelling.

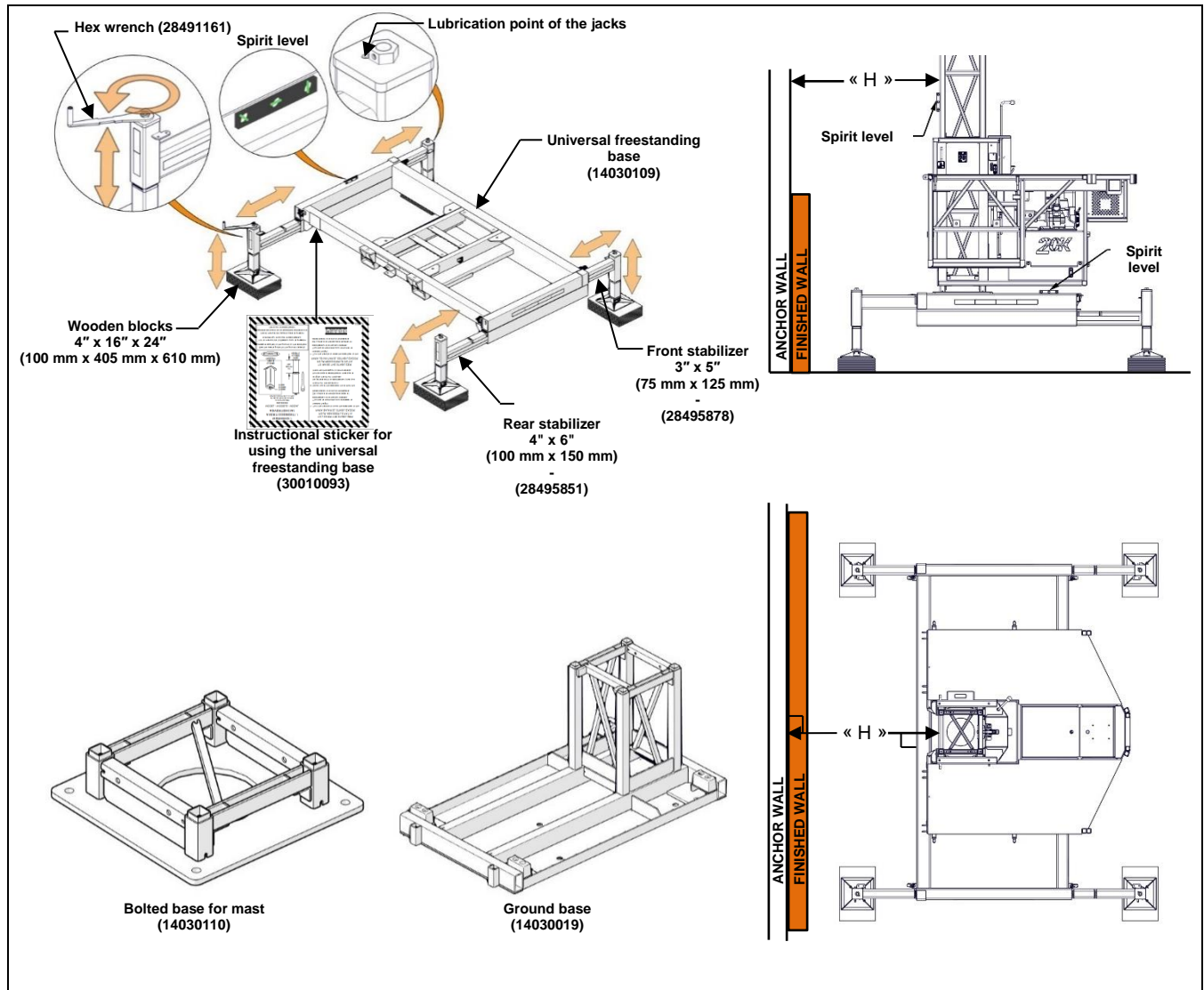


Figure 54 - Installation of universal freestanding base

## Installation with universal freestanding base (14030109) (CONTINUED)

The universal freestanding base is compatible with the ground base (14030019) and the mast bolted base (14030110).

**Important!** The bases must be bolted with 1"-8UNC x 3-1/2", gr8 zinc or A325 galv. bolting kits.

A325 galv. bolting kits **must not be used** to assemble the mast sections (13030041) between them. A325 galv. bolting kits must also not be used for assemblies between mast section (13030041) and ground base (14030019) or bolted base (14030110).

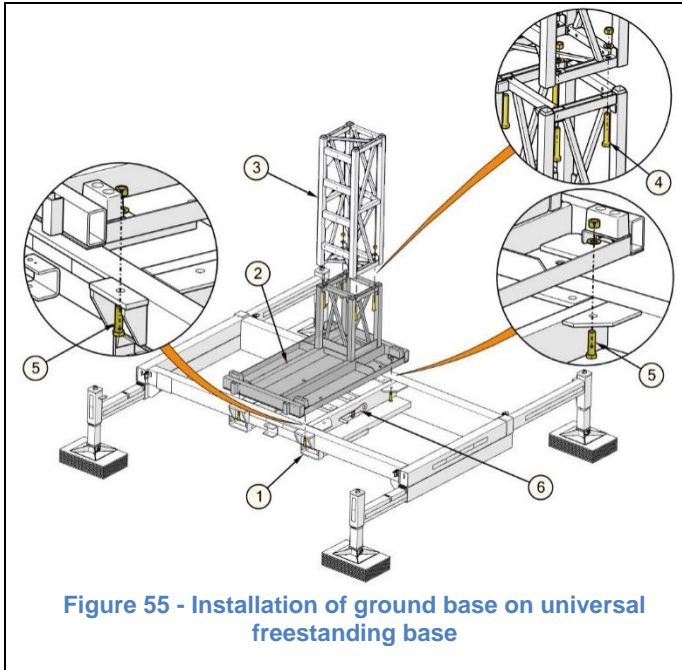


Figure 55 - Installation of ground base on universal freestanding base

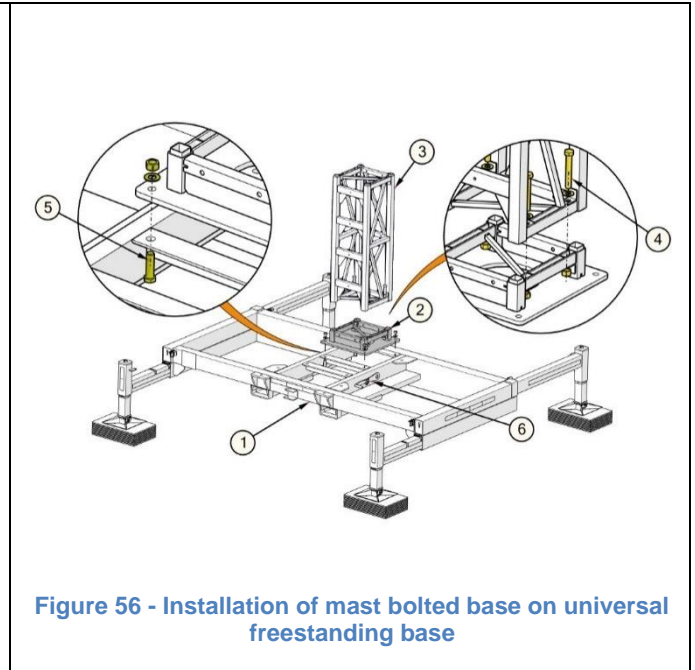


Figure 56 - Installation of mast bolted base on universal freestanding base

No	Item	Description	No	Item	Description
01	14030109	Universal freestanding base	01	14030109	Universal freestanding base
02	14030019	Ground base for 20" x 20" mast (3'-6" x 6'-0")	02	14030110	Bolted base for 20" x 20" mast (6'-1/2")
03	13030018	Mast section 20" x 20" x 5'-0" with rail (ACT)	03	13030018	Mast section 20" x 20" x 5'-0" with rail (ACT)
04	BOZ-7305 or BOA-2080	Bolt kit 1"-8unc x 6-1/2", gr8 zinc or Bolt kit 1"-8unc x 6-1/2", A325	04	BOZ-7305 or BOA-2080	Bolt kit 1"-8unc x 6-1/2", gr8 zinc or Bolt kit 1"-8unc x 6-1/2", A325
05	BOA-2072	Bolt kit 1"-8unc x 3-1/2", A325	05	BOA-2072	Bolt kit 1"-8unc x 3-1/2", A325
06	28491161	Hex wrench 1-5/8"	06	28491161	Hex wrench 1-5/8"

## Installation with 20K freestanding base (14030053)

**Step 1** – Pull the front and rear stabilizers of the base as far as possible and lower the legs of the stabilizers on to wooden blocks. For installations over 100'-0" (30 m) high, retract the stabilizers in the closed position as shown in [Figure 42](#) and install shoring pads directly under the mast. It is important to respect the **MAXIMUM** limits of opening stickers as shown in [Figure 138](#), ON PAGE 149.

**Step 2** – Accurately measure the « H » distance between the mast and the anchor wall and validate perpendicularity to the wall.

∞SEE FIGURE 6 - CLEARANCE TO FINISHED WALLS AND AROUND THE UNITS, ON PAGE 12

∞SEE TABLE 1 - DIMENSIONS AND CLEARANCE, ON PAGE 13

**Step 3** – Check that the base (not the platform) is perfectly horizontal using a level. Ensure that the stabilizers are centered in the middle of the shoring pads. To level the base, use the hex wrench to adjust the stabilizer jacks.

**Step 4** – Install the ground base (14030019) or the bolted base (14030110) directly onto the 20K universal freestanding base (14030053) as shown in [Figure 55](#). Then, bolt the first mast section of the lifting unit (13030041) to the ground base (14030019) or the bolted base (14030110).

**Step 5** – Bolt a mast section (13030041) above the one already present in the unit. Lift the unit approximately 18" (460 mm) and bolt all the mast bolts with an impact wrench. Check that the mast is perfectly vertical using a level.

**Step 6** – Lower the unit to its lowest position and recheck general levelling.

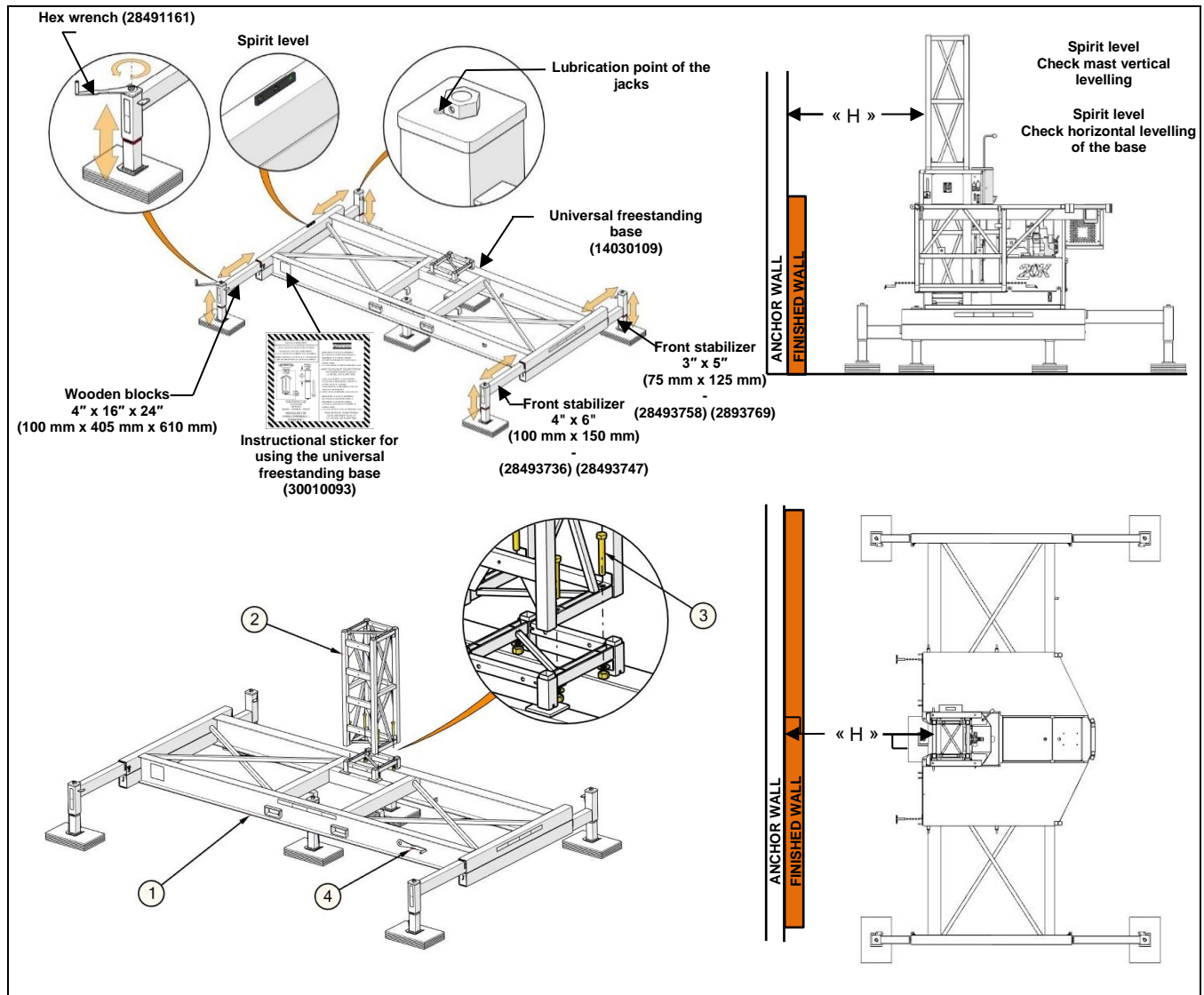
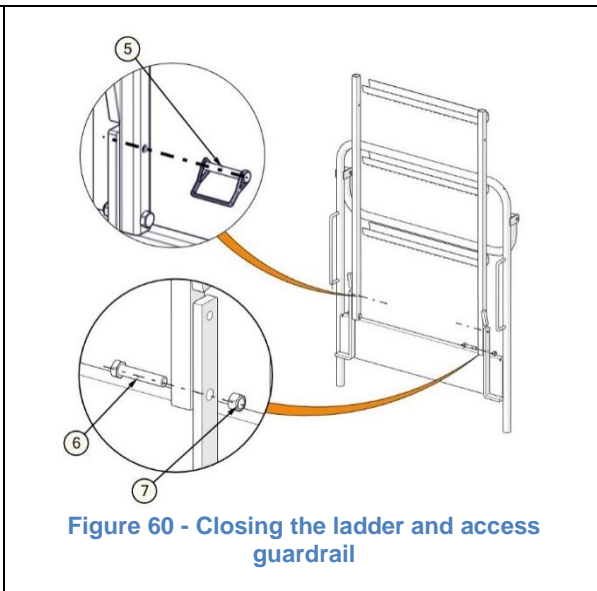
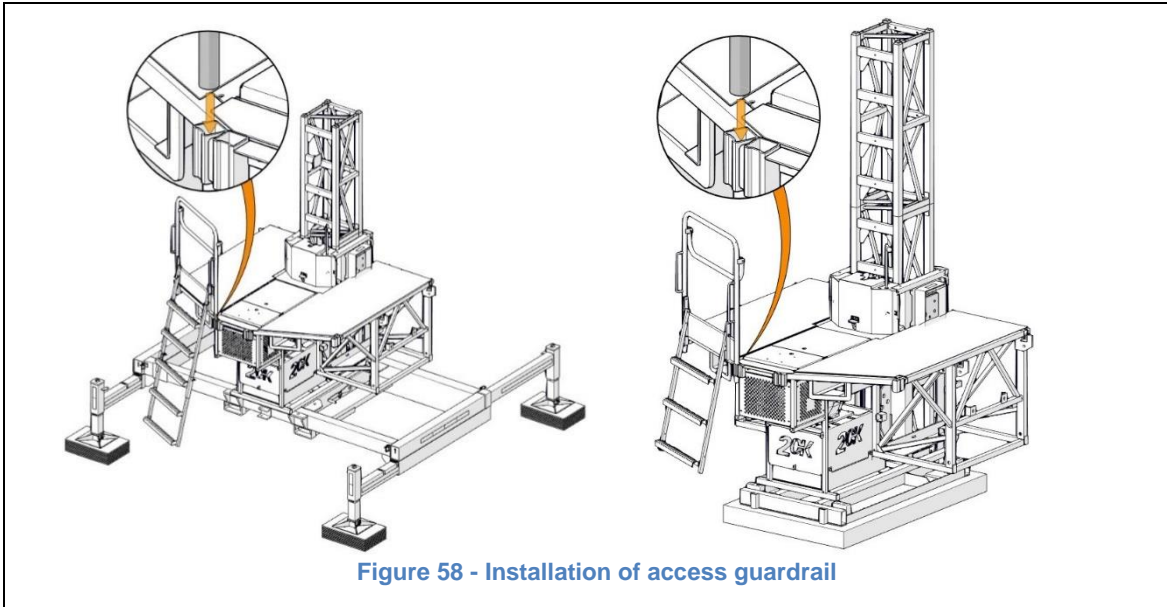


Figure 57 - Installation of 20K freestanding base

No	Item	Description	No	Item	Description
01	14030053	ACT8 freestanding base	03	BOZ-7305	Bolt kit 1"-8unc x 6-1/2", gr8 zinc
02	13030041	Mast section 20" x 20" x 5'-0" with bars (FRSM-20K)	04	28491161	Hex wrench 1-5/8"

## Installation of the guardrail with ladder

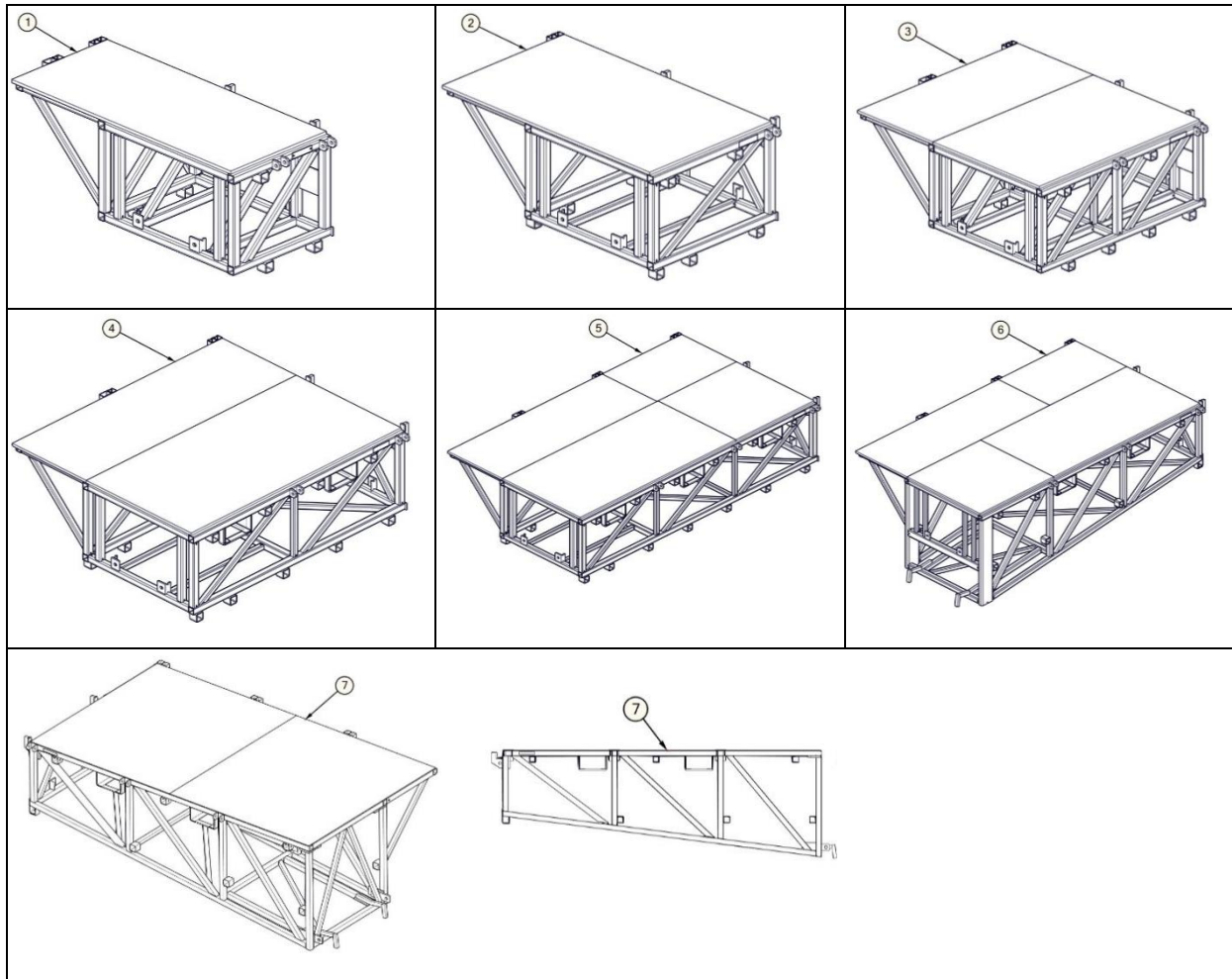


No	Item	Description	No	Item	Description
01	28071226	Guardrail segment	05	GOU-5040	Locking pin 3/8" x 2-1/2" x 1-1/2"
02	28494197	Access guard-rails	06	BOZ-7165	Bolt 1/2"-13unc x 2-1/2" gr5 zinc
03	28494204	Retractable ladder, access guardrail	07	NYL-2030	Nylon lock nut 1/2"-13unc gr5 zinc
04	20491567	Access guard-rail ladder extension (FRSM-20K)			

## Extension section

### MODULAR extension section

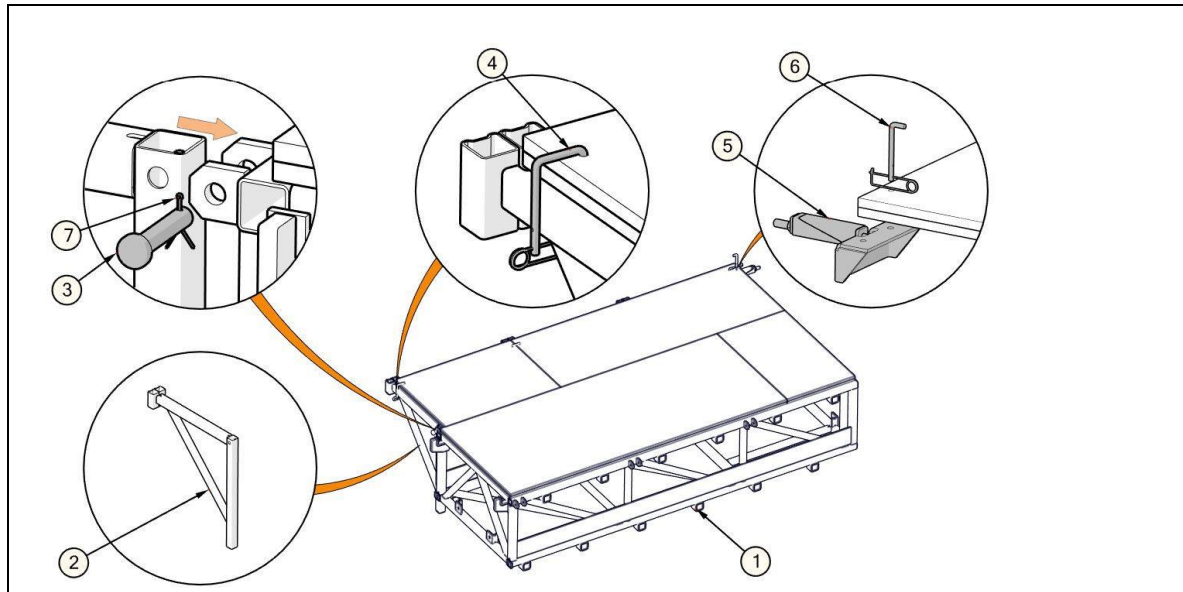
The extension sections are used to extend the platform part of the lifting unit.  
The « **MODULAR** » sections do not include any removable components.



No.	FRACO Code	Description
1	15090016 (Left) 15090094 (Right)	Intermediate extension section 2'-6" x 5'-9" (762 mm x 1,75 m) left (green) Intermediate extension section 2'-6" x 5'-9" (762 mm x 1,75 m) right (blue)
2	15090027 (Left) 15090106 (Right)	Extension section 3'-4" x 5'-9" (1 m x 1,75 m) left (green) Extension section 3'-4" x 5'-9" (1 m x 1,75 m) right (blue)
3	15090038 (Left) 15090117 (Right)	Intermediate extension section 5'-0" x 5'-9" (1,52 m x 1,75 m) left (green) Intermediate extension section 5'-0" x 5'-9" (1,52 m x 1,75 m) right (blue)
4	15090049 (Left) 15090128 (Right)	Extension section 6'-8" x 5'-9" (2 m x 1,75 m) left (green) Extension section 6'-8" x 5'-9" (2 m x 1,75 m) right (blue)
5	15090050 (Left) 15090139 (Right)	Extension section 10'-0" x 5'-9" (3 m x 1,75 m) left (green) Extension section 10'-0" x 5'-9" (3 m x 1,75 m) right (blue)
6	15090184 (Left) 15090195 (Right)	Universal taper extension section 10'-0" x 5'-9" (3 m x 1,75 m) left (orange) Universal taper extension section 10'-0" x 5'-9" (3 m x 1,75 m) right (white)
7	15060013 (Left) 15060024 (Right)	Tapered extension section 10'-0" x 5'-9" (3 m x 1,75 m) left (green) Tapered extension section 10'-0" x 5'-9" (3 m x 1,75 m) right (blue)

## NON-MODULAR extension section

The « **NON-MODULAR** » sections have removable and reversible brackets as illustrated below.



No.	FRACO Code	Description
1	150200XX	Non-modular extension section (Example)
2	18490046	2'-4" bracket with 3/4" hole
3	25490055	Locking pin Ø 3/4" x 4-3/16"
4	25490088	U-pin. Ø 3/8" (2-7/8" x 4-3/4") assembled
5	20490959	Plywood support for extension system
6	25490099	Half-U-pin Ø 3/8" x 4-3/4" assembled
7	GOU-1120	Split Pin 1/8" x 2" zinc
« 8 »	15020019	Extension section 2'-6" x 3'-6" (762 mm x 1,07 m)
« 9 »	15020020	Extension section 3'-4" x 3'-6" (1,00 m x 1,07 m)
« 10 »	15020031	Extension section 6'-8" x 3'-6" (2,00 m x 1,07 m)
« 11 »	15020042	Extension section 10'-0" x 3'-6" (3,0 m x 1,07 m)
« 12 »	15020086	Taper extension section 10'-0" x 3'-6" (3,0 m x 1,07 m)

Note: Items numbered between « » are not shown in the illustration.



## Installation of an extension section

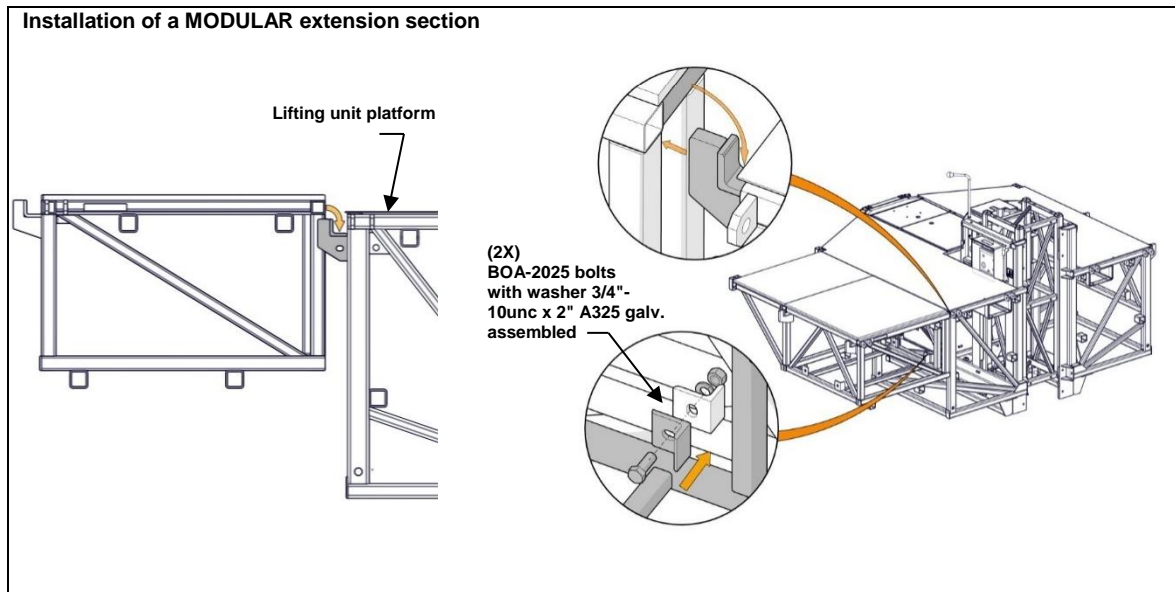


Figure 61 - MODULAR extension section

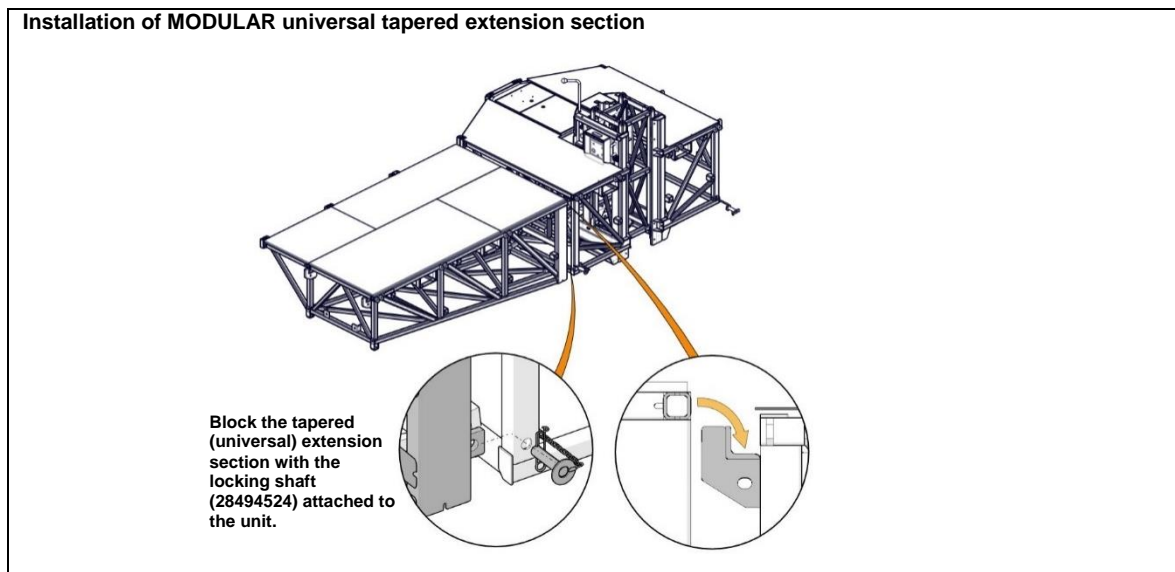


Figure 62 - MODULAR tapered (universal) extension section

## Installation of an extension section (CONTINUED)

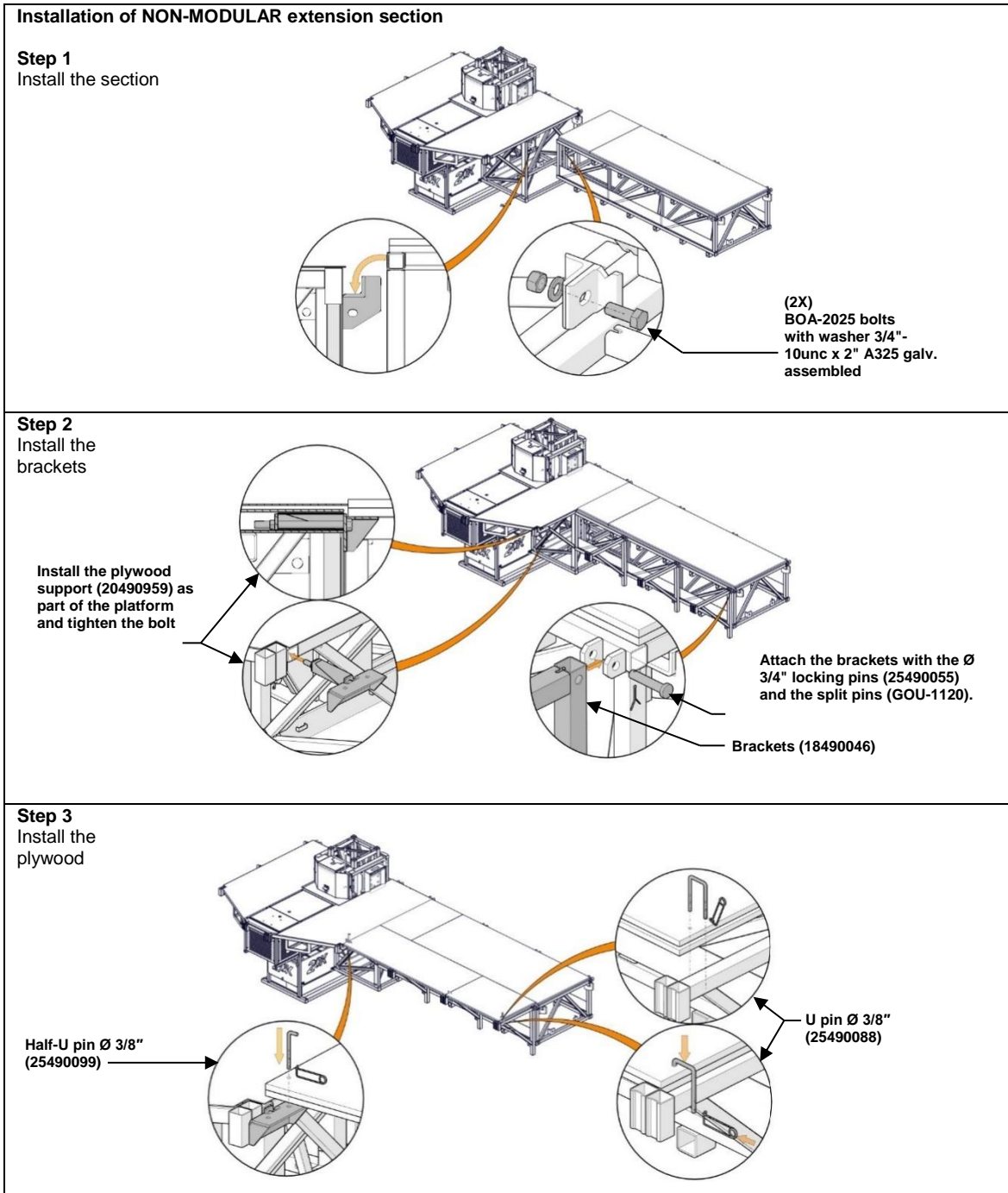


Figure 63 - NON-MODULAR extension section

## Installation of extension section joints (20490566)

Extension section joints are required to join a **MODULAR** extension section to a **NON MODULAR** section.

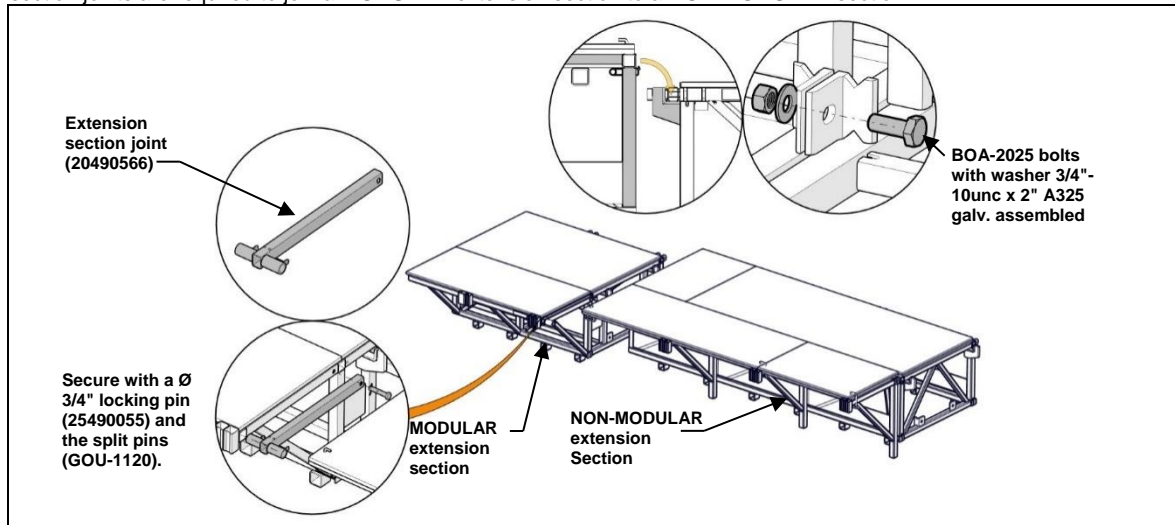


Figure 64 - MODULAR Extension joint

### Installation of tapered extension sections with protective hook supports

The protective supports **must** be present on all tapered extension models installed on a 20K platform. This preventive measure prevents the hooks from breaking in the event of mishandling during dismantling.

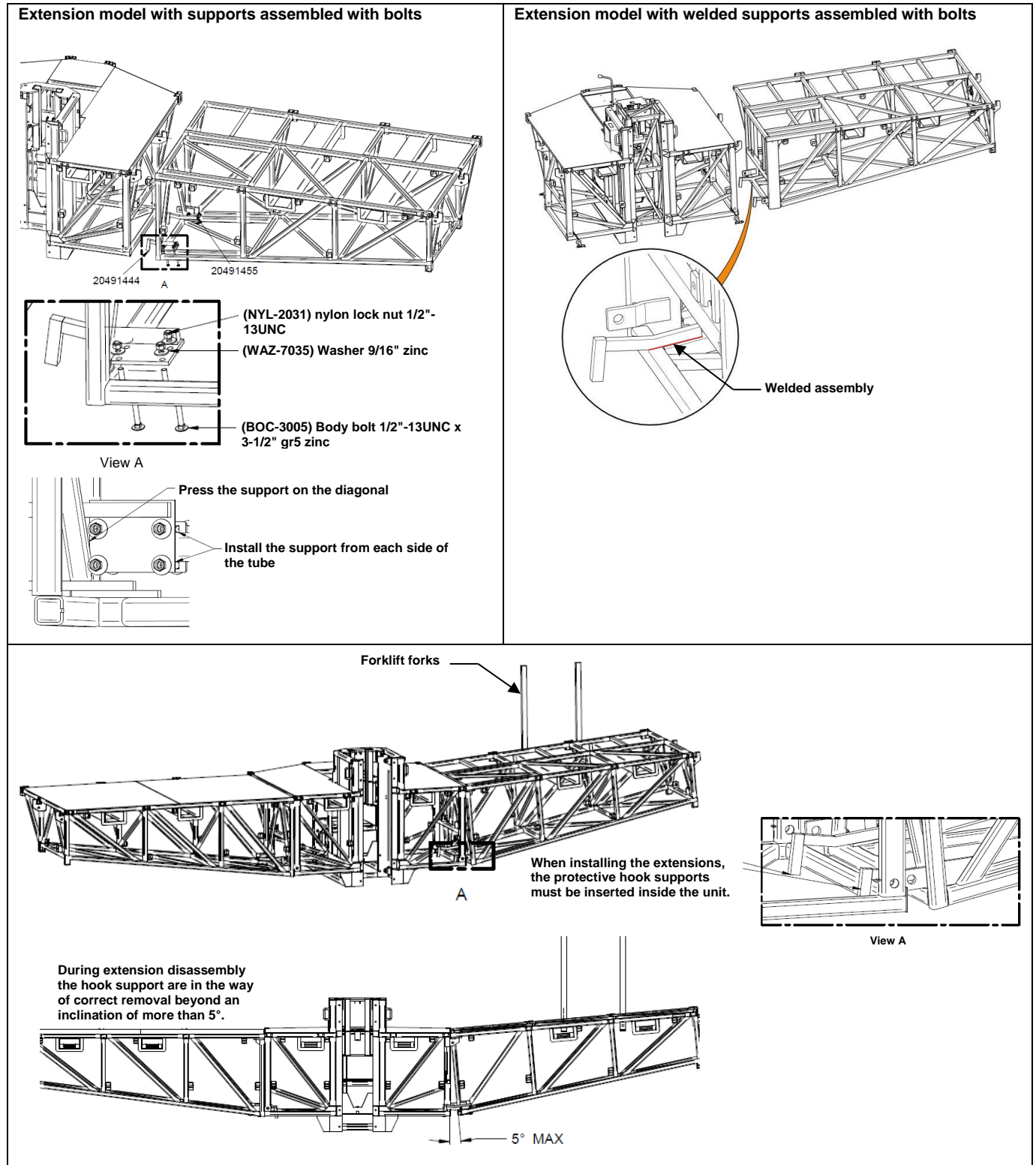


Figure 65 - Tapered extensions with protective hook supports

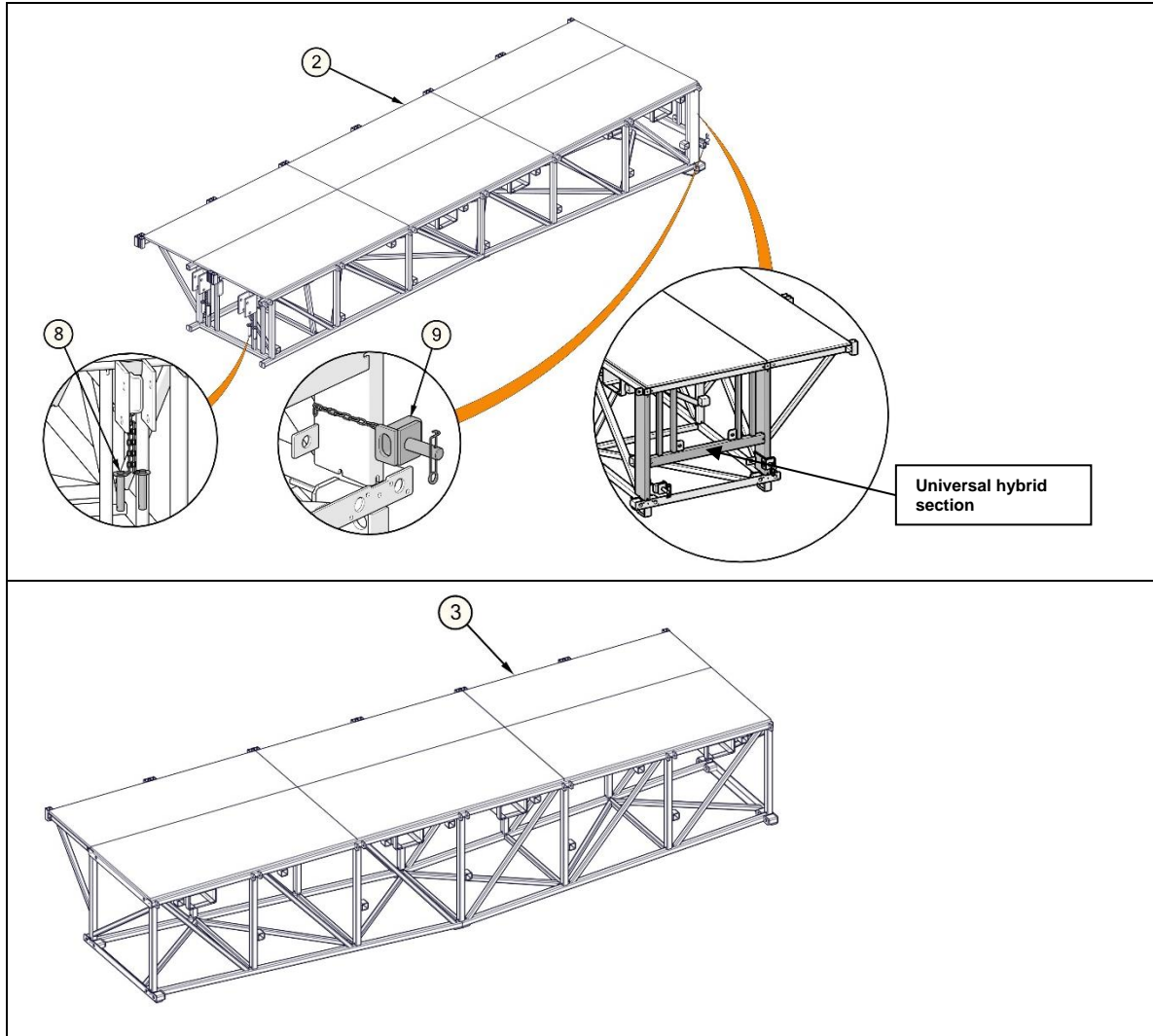
## Bridge section

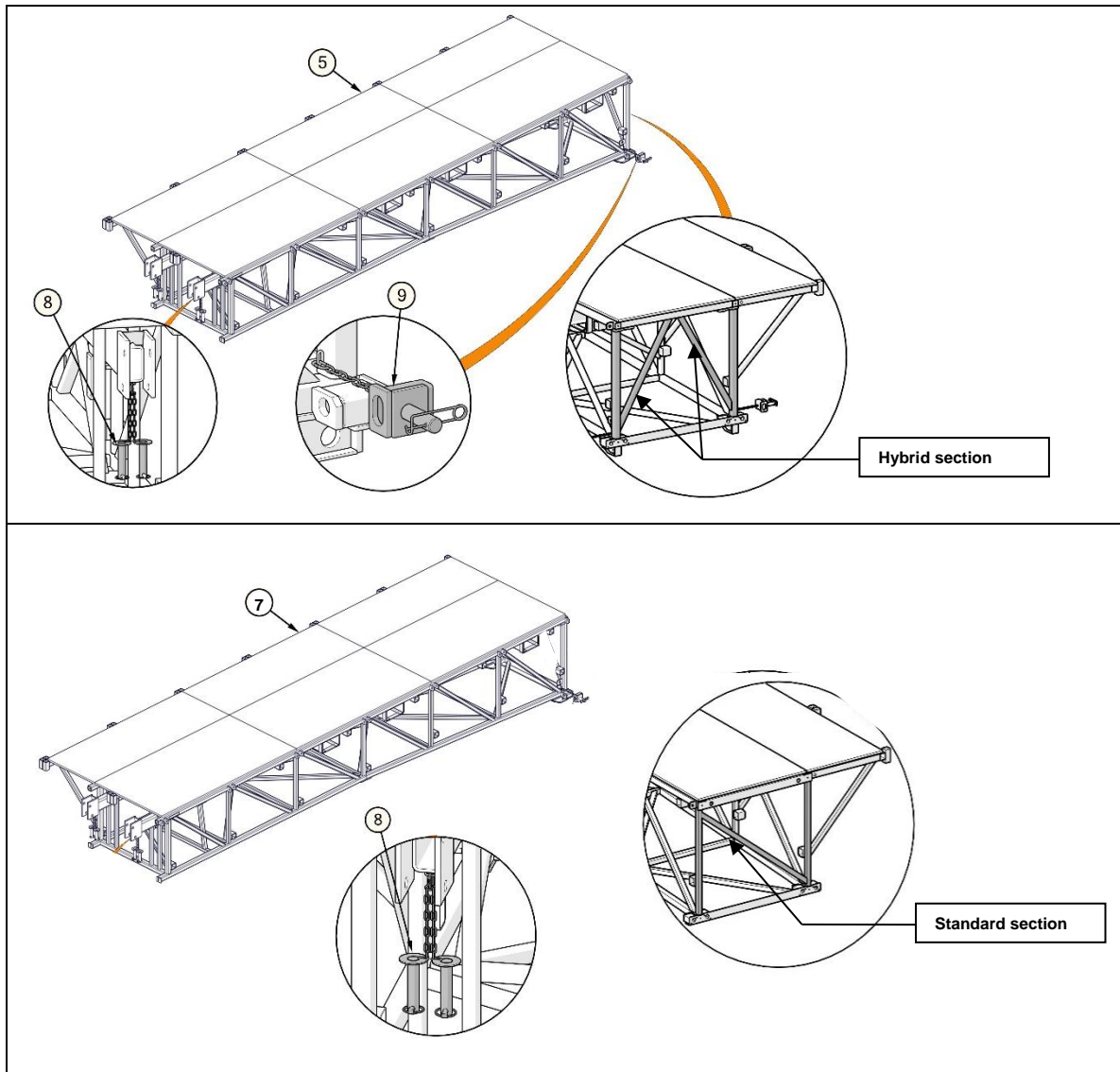
### MODULAR bridge section

The bridge sections link two units installed on independent masts.

There are three (3) types of **MODULAR** bridge sections: « Universal hybrid », « Hybrid », « Standard ».

- The « Universal hybrid » bridges can be used as a bridge on the **20K units**.
- The « Universal hybrid » bridges can be used as an extension on the **20K units**.
- The « Hybrid » bridges can be used as a bridge on the **20K units**.
- The « Hybrid » bridges can be used as extensions on **the 20K units**.
- The « Standard » bridges can only be used as a bridge on the **20K units**.
- The « Standard » bridges **cannot** be used as extensions.



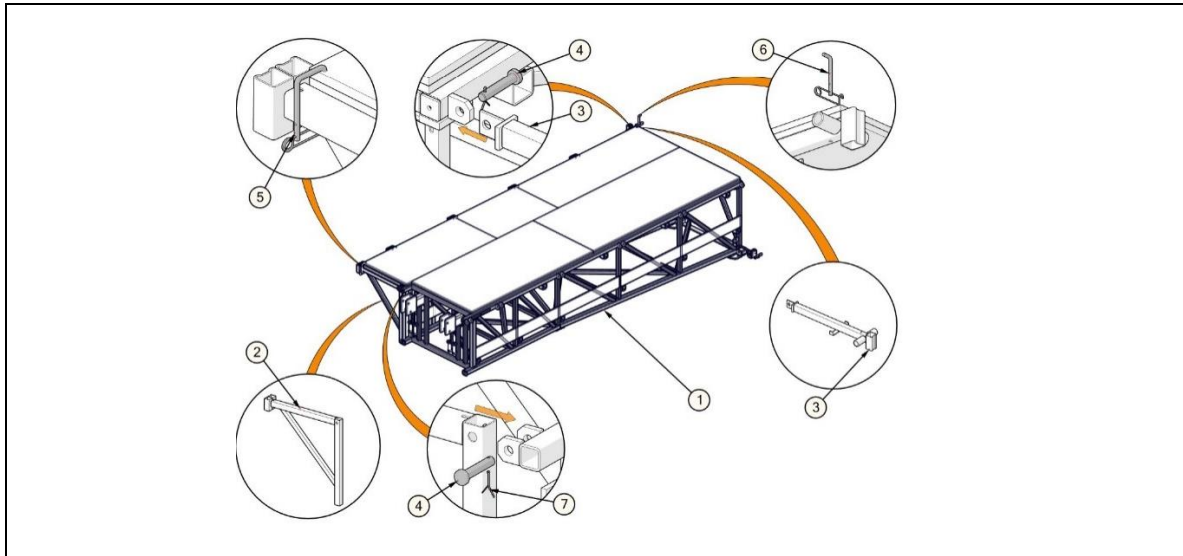


No.	FRACO Code	Description
« 1 »	15090229 (Left)	Hybrid – Universal) bridge section (MODULAR) 5'-9" x 15'-0" (1,75 m x 4,57 m) left (orange)
	15090230 (Right)	(Hybrid – Universal) bridge section (MODULAR) 5'-9" x 15'-0" (1,75 m x 4,57 m) right (white)
2	15090207 (Left)	(Hybrid – Universal) bridge section (MODULAR) 5'-9" x 20'-0" (1,75 m x 6,10 m) Right (White)
	15090218 (Right)	(Hybrid – Universal) bridge section (MODULAR) 5'-9" x 20'-0" (1,75 m x 6,10 m) right (white)
3	15090083 (Centre)	Central bridge section (MODULAR) 5'-9" x 20'-0" (1,75 m x 6,10 m)
« 4 »	15090061 (Left)	(Hybrid) Bridge section (MODULAR) 5'-9" x 15'-0" (1,75 m x 4,57 m) left (green)
	15090140 (Right)	(Hybrid) Bridge section (MODULAR) 5'-9" x 15'-0" (1,75 m x 4,57 m) right (blue)
5	15090072 (Left)	(Hybrid) Bridge section (MODULAR) 5'-9" x 20'-0" (1,75 m x 6,10 m) left (green)
	15090151 (Right)	(Hybrid) Bridge section (MODULAR) 5'-9" x 20'-0" (1,75 m x 6,10 m) right (blue)
« 6 »	15030054 (Left)	Bridge section (MODULAR) 5'-9" x 15'-0" (1,75 m x 4,57 m) left (green)
	15030133 (Right)	Bridge section (MODULAR) 5'-9" x 15'-0" (1,75 m x 4,57 m) right (blue)
7	15090205 (Left)	Bridge section (MODULAR) 5'-9" x 20'-0" (1,75 m x 6,10 m) left (green)
	15090206 (Right)	Bridge section (MODULAR) 5'-9" x 20'-0" (1,75 m x 6,10 m) right (blue)
8	28493938 + GOU-6040 + FOD-5325	Double bridge arm chain
9	28494906	Locking shaft Ø 1,000" x 3,188" with 9,500" chain

Note: Items numbered between « » are not shown in the illustrations.

### NON-MODULAR bridge section

The « **NON MODULAR** » sections have removable and reversible brackets as illustrated below.



No.	FRACO Code	Description
1	150200XX	NON-MODULAR bridge section (Example)
2	18490046	Side bracket with 3/4" hole 2'-4"
3	20490577	MODULAR bridge joint with bottle
4	25490055	Pin dia. 3/4" x 4-3/16"
5	25490088	U-lock pin Ø 3/8" x 2-7/8" x 4-3/4" assembled
6	25490099	Half-U-pin Ø 3/8" x 4-3/4" assembled
7	GOU-1120	Split Pin 1/8" x 2" zinc
« 8 »	15020097	NON-MODULAR Hybrid bridge section 3'-6" x 15'-0" (1,07 m x 4,57 m) (orange – white)
« 9 »	15020109	NON-MODULAR Hybrid bridge section 3'-6" x 20'-0" (1,07 m x 6,10 m) (orange – white)
« 10 »	15020075	Central bridge section 3'-6" x 20'-0" (1,07 m x 6,10 m)

Note: Items numbered between « » are not shown in the illustration.

## Installation of bridge section

### Examples of bridge section combinations



Bridge assembly 20'-0" (6,10 m), with bridge end adapter

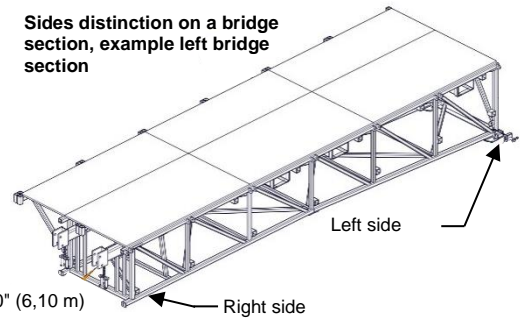


Bridge assembly 40'-0" (12,20 m), with two (2) bridges 20'-0" (6,10 m)



Bridge assembly 60'-0" (18,30 m), with two (2) bridges of 20'-0" (6,10 m) and a central bridge 20'-0" (6,10 m)

Sides distinction on a bridge section, example left bridge section



### List of all possible bridge combinations

Note: Only the MODULAR « universal hybrid » bridge sections are shown in the components list in the table below, but all combinations can also be made using « Hybrid » and « Standard » bridge sections.

Result	Components list	
Bridge 15'-0" (4,57 m)	Bridge section 15'-0" (4,57 m)	(15090229-left) or (15090230-right) + bridge end adapter (20491501)
Bridge 20'-0" (6,10m)	Bridge section 20'-0" (6,10m)	(15090207-left) or (15090218-right) + bridge end adapter (20491501)
Bridge 30'-0" (9,15 m)	Bridge section 15'-0" (4,57 m) Bridge section 15'-0" (4,57 m)	(15090229-left) or (15090230-right) + (15090229-left) or (15090230-right)
Bridge 35'-0" (10,67 m)	Bridge section 15'-0" (4,57 m) Bridge section 20'-0" (6,10m)	(15090229-left) or (15090230-right) + (15090207-left) or (15090218-right)
Bridge 40'-0" (12,20 m)	Bridge section 20'-0" (6,10m) Bridge section 20'-0" (6,10m)	(15090207-left) or (15090218-right) + (15090207-left) or (15090218-right)
Bridge 50'-0" (15,25m)	Bridge section 15'-0" (4,57 m) Central bridge section 20'-0" (6,10 m) Bridge section 15'-0" (4,57 m)	(15090229-left) or (15090230-right) + (15090083) + (15090229-left) or (15090230-right)
Bridge 55'-0" (16,75 m)	Bridge section 15'-0" (4,57 m) Central bridge section 20'-0" (6,10 m) Bridge section 20'-0" (6,10 m)	(15090229-left) or (15090230-right) + (15090083) + (15090207-left) or (15090218-right)
Bridge 60'-0" (18,30 m)	Bridge section 20'-0" (6,10 m) Central bridge section 20'-0" (6,10 m) Bridge section 20'-0" (6,10 m)	(15090207-left) or (15090218-right) + (15090083) + (15090207-left) or (15090218-right)

For any questions about bridge section combinations, contact the FRACO engineering department.

### Example of a bridge section to bridge section assembly

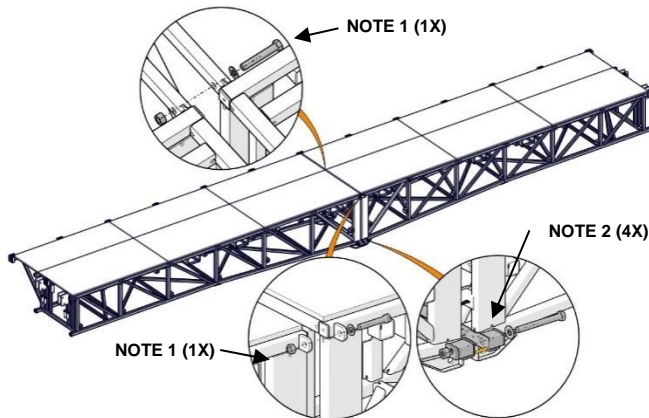


Figure 66 - Combination 20'-0" to 20'-0"

### Example of assembly between bridge section and central section

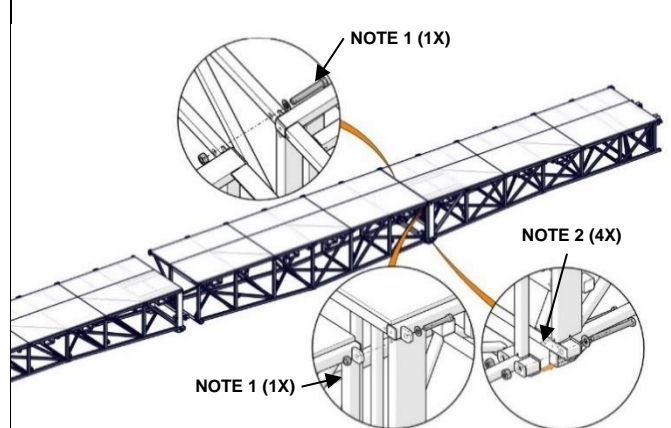


Figure 67 - Combination 20'-0" to centre

No	Item	Description	No	Item	Description
01	BOA-2090	Bolting kit with washer and nut Ø 3/4"-10unc x 4-1/2" A325, galv.	02	BOA-2085	Bolting kit with washer and nut Ø 1"-8unc x 9" A325, galv.



### Installation of bridge joint with bottle (20490577)

Bridge joints are required to join a **MODULAR** bridge section to a **NON MODULAR** bridge section.

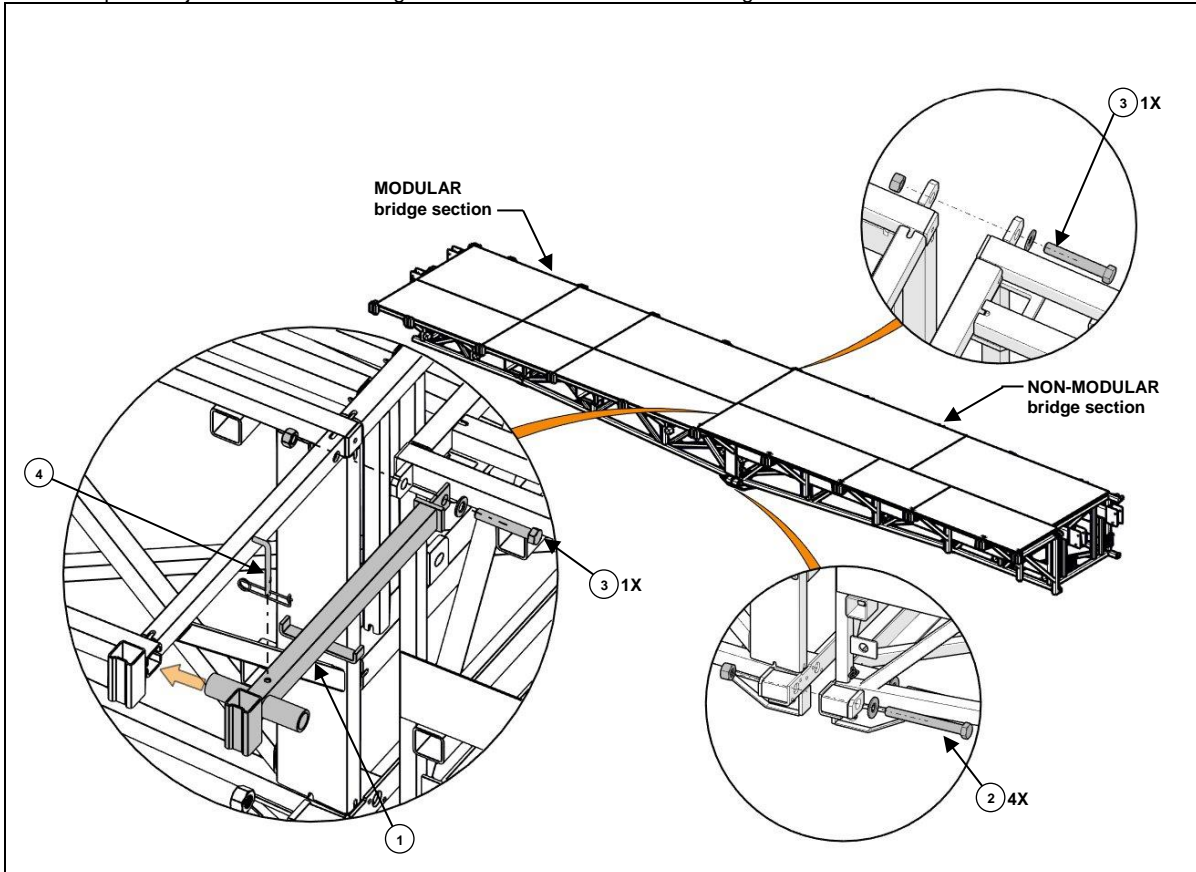


Figure 68 - Bridge joint with bottle

No	Item	Description	No	Item	Description
01	20490577	Bridge joint with bottle	03	BOA-2090	Bolt kit with washer and nut Ø 3/4"-10unc x 4-1/2" A325, galv.
02	BOA-2085	Bolt kit with washer and nut Ø 1"-8unc x 9" A325, galv.			

### Installation of 15'-0" or 20'-0" individual bridge section between two (2) units

Install a 15'-0" (4,57 m) or 20'-0" (6,10 m) bridge section directly between two (2) lifting units.

Note: When installing **only one** 15'-0" (4,57 m) or 20'-0" (6,10 m) bridge section, it is **mandatory** to use a bridge end adapter (20491501).

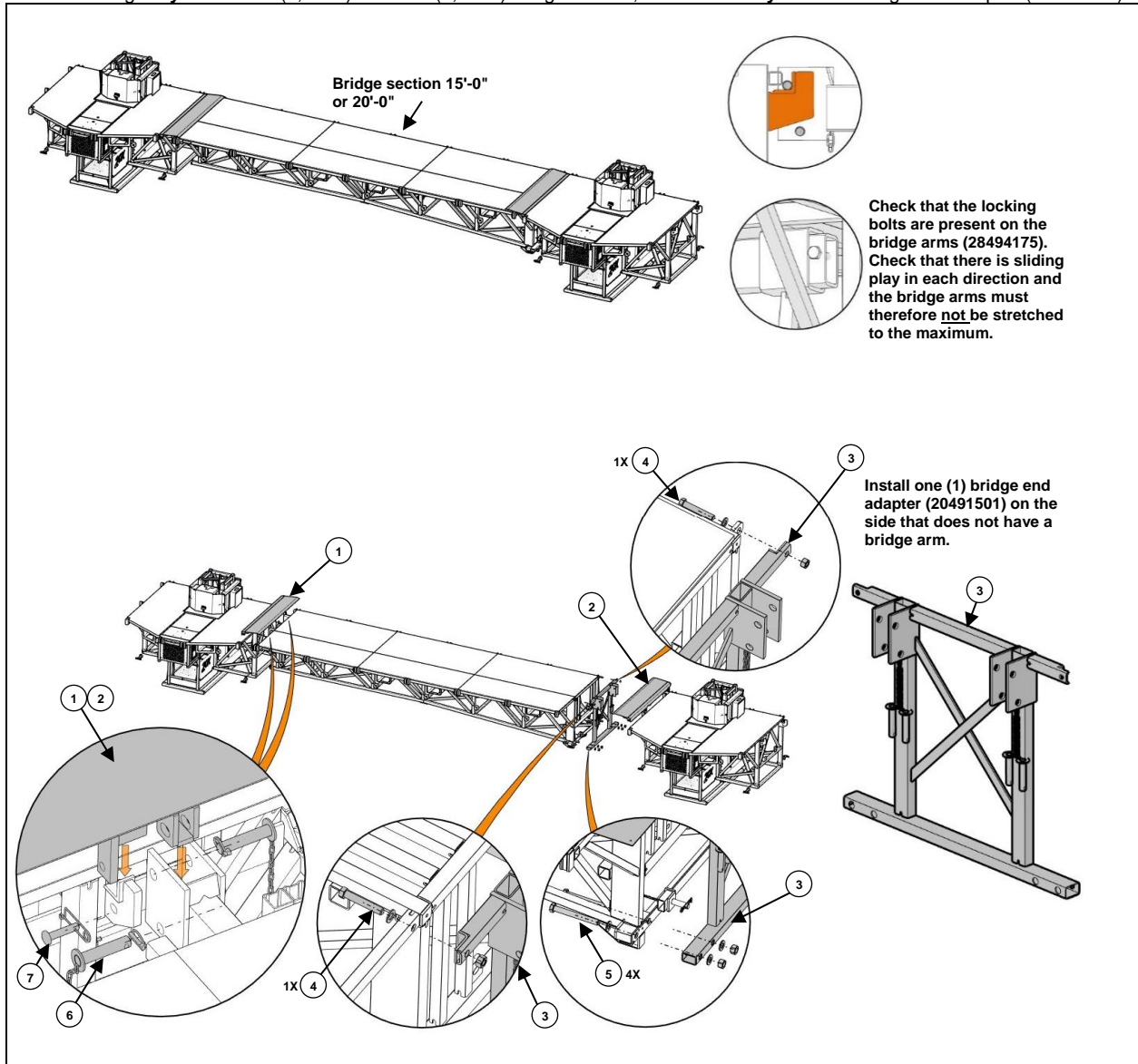


Figure 69 - Installation of 15'-0" or 20'-0" bridge section between lifting units

No	Item	Description	No	Item	Description
01	20490689	Bridge arm adapter (assembled.) right (blue)	05	BOA-2085	Bolt kit with washer and nut Ø 1"-8unc x 9" A325, galv.
02	20490690	Bridge arm adapter (assembled.) left (green)	06	28493938	Double bridge arm chain
03	20491501	Bridge end adapter (3'-0" x 4'-0")	07	25490033 + GOU-5020	Pin (dia. 5/8" x 3-3/16") Safety pin 1/8" x 4-1/4"
04	BOA-2090	Bolt kit with washer and nut Ø 3/4"-10unc x 4-1/2" A325, galv.			

## Installation of individual 15'-0" or 20'-0" bridge section on intermediate units and/or extensions

Install a 15'-0" (4,57 m) or 20'-0" (6,10 m) bridge section directly between two (2) lifting units and/or between intermediate extensions.

Note: When installing **only one** 15'-0" (4,57 m) or 20'-0" (6,10 m) bridge section, it is **mandatory** to use a bridge end adaptor (20491501).

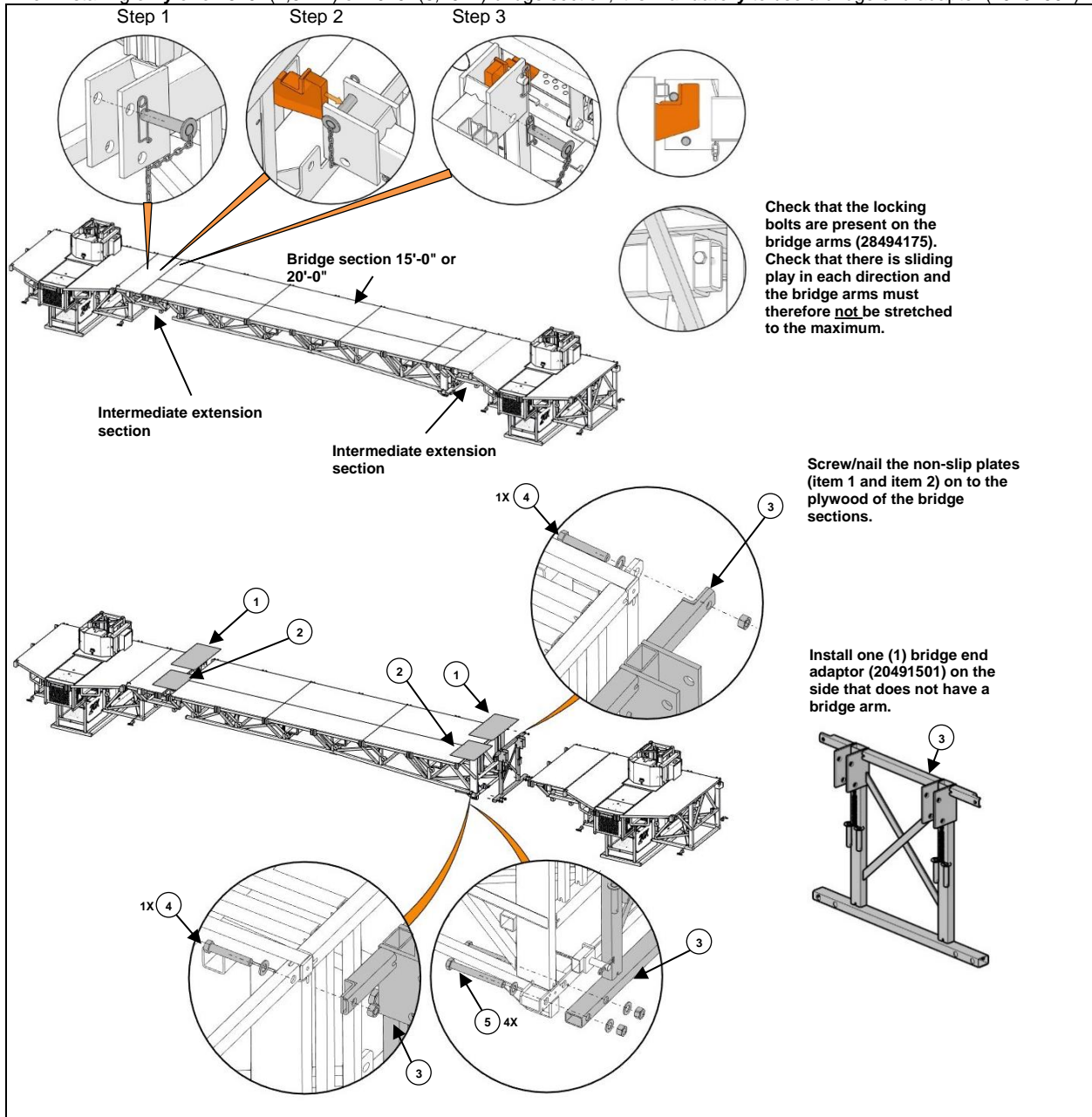


Figure 70 - Installation of 15'-0" or 20'-0" bridge section between lifting units and/or intermediate extensions

No	Item	Description	No	Item	Description
01	20490320	Anti skid steel plate (1/8" x 20" x 39-1/2")	04	BOA-2090	Bolt kit with washer and nut Ø 3/4"-10unc x 4-1/2" A325, galv.
02	20490319	Anti skid steel plate (1/8" x 20" x 2'-4")	05	BOA-2085	Bolt kit with washer and nut Ø 1"-8unc x 9" A325, galv.
03	20491501	Bridge end adaptor (3'-0" x 4'-0")			

## Installation of 30'-0" to 60'-0" bridge assembly between two (2) units and/or intermediate extensions

Assemble 15'-0" (4,57 m) or 20'-0" (6,10 m) bridge sections and install the bridge assembly between two (2) lifting units and/or intermediate extensions.

For admissible bridge combinations, SEE INSTALLATION OF BRIDGE SECTION, ON PAGE 55.

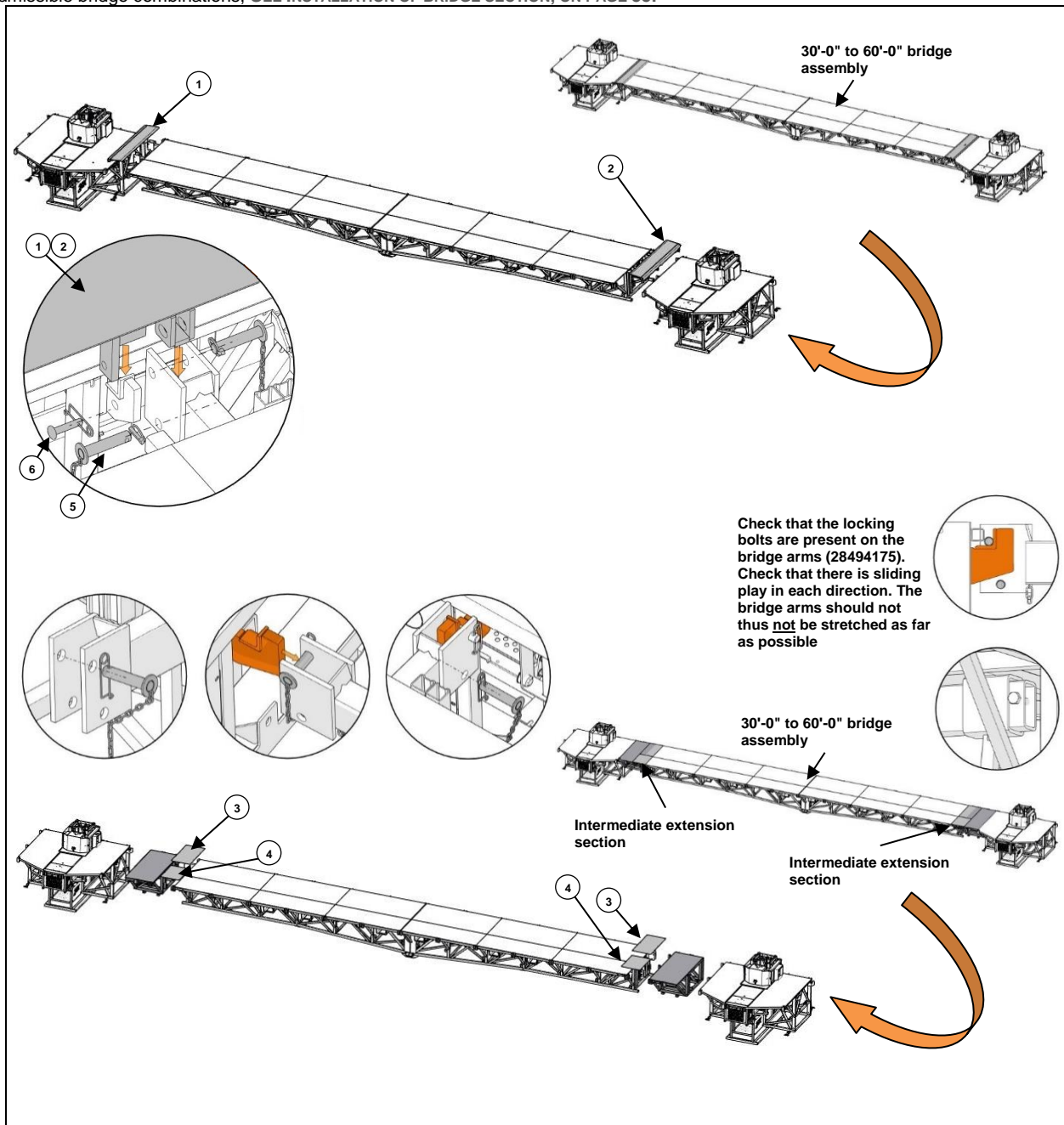


Figure 71 - Installation of 30'-0" to 60'-0" bridge assembly on the lifting unit and/or intermediate extensions

No	Item	Description	No	Item	Description
01	20490689	Bridge arm adapter (assembled) right (blue)	04	20490319	Anti skid steel plate (1/8" x 20" x 2'-4")
02	20490690	Bridge arm adapter (assembled) left (green)	05	28493938	Double bridge arm chain
03	20490320	Anti skid steel plate (1/8" x 20" x 39-1/2")	06	25490033" GOU-5020	Pin (dia. 5/8" x 3-3/16") Safety pin 1/8" x 4-1/4"

## Installation of an extension bridge section

**Important!** This is a **special installation** and thus requires special attention.

For conditions of use. **SEE BRIDGE SECTION, ON PAGE 52.**

- It is possible to use a « **Universal hybrid** » 15'-0" (4,57 m) or 20'-0" (6,10 m) bridge section as an extension, directly on the lifting unit. **Excludes central bridge sections.**
- It is possible to use a « **Hybrid** » 15'-0" (4,57 m) or 20'-0" (6,10 m) bridge section as an extension directly on the lifting unit. **Excludes central bridge sections.**

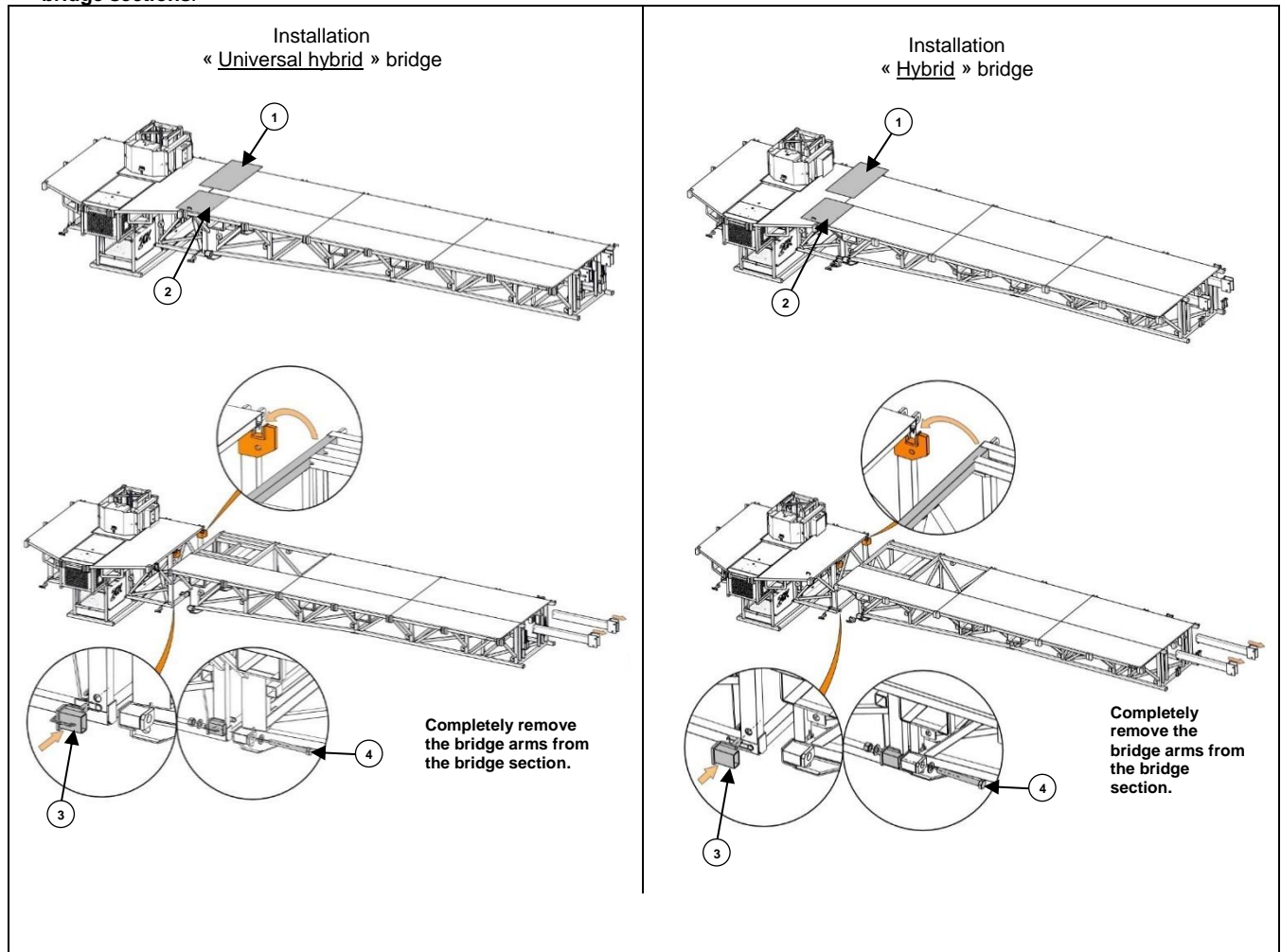


Figure 72 - Installation of an extension bridge section

No	Item	Description	No	Item	Description
01	20490320	Anti skid steel plate 1/8" x 20" x 39-1/2"	03	28494906	Locking shaft Ø 1,000" x 3,188" with 11,00" chain
02	20490319	Anti skid steel plate (1/8" x 20" x 2'-4")	04	BOA-2085	Bolt kit with washers and nut Ø 1"-8unc x 9" A325, galv.

## Bolting mast sections and mast end section

Assemble the mast sections by joining the male and female ends with the four (4) bolts (BOZ-7305 or BOA-2080). Tighten the bolts according to the prescribed tightening torque. **SEE TABLE 16 - TECHNICAL DATA SHEET 20K mast section, ON PAGE 150.**

**Note:** For all of the following explanations, « mast sections » means an individual part (13030041) and « mast » means an assembly of two (2) or more mast sections. The masts may be pre-assembled on the ground or erected one section at a time.

**IMPORTANT!** The bolts must always be installed from below, with nut and washer on top.

Install the mast end section to the last installed mast section using four (4) bolting kits (BOZ-7305) (BOZ-7305). Tighten the bolts according to the prescribed tightening torque.

The tightening torque of the mast section bolts should be close to **265 lb-ft (360 Nm)**.

**Do not exceed the following vertical tolerances:**

- 1/2" (13 mm) for a 10'-0" mast (3,0 m).
- 3/4" (19 mm) for a 20'-0" mast (6,1 m).
- 1" (25 mm) for the maximum mast height.

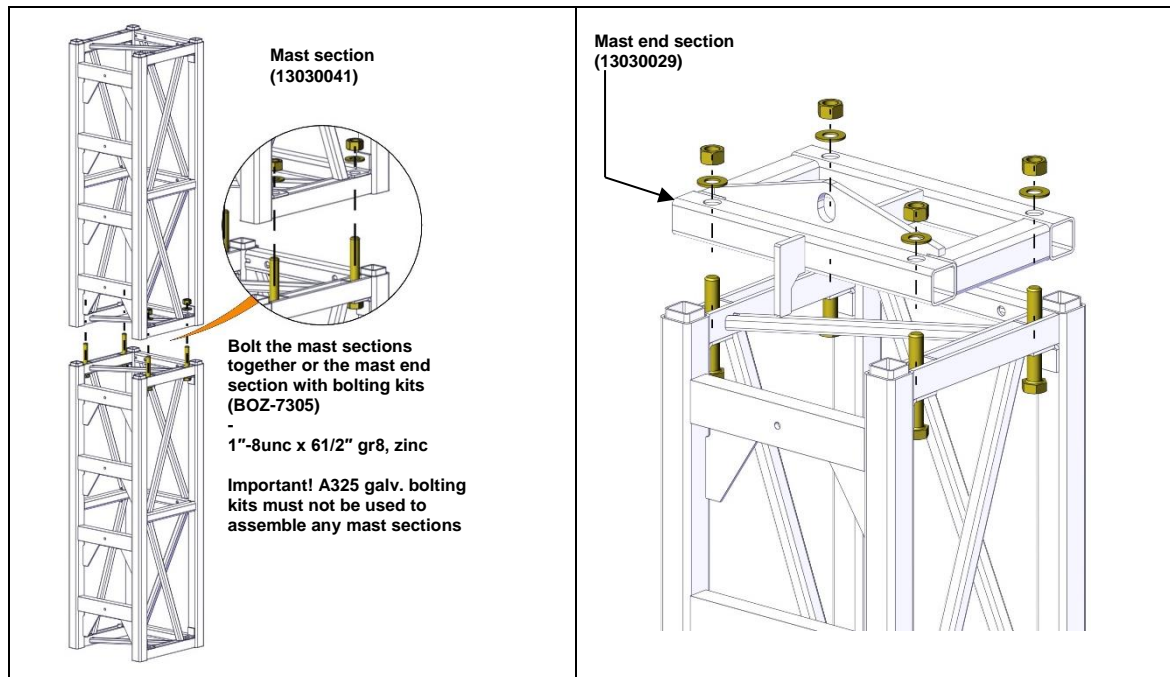


Figure 73 - Bolting mast and mast end sections

## Mast anchor

For information on detailed parts, **FRACO** part numbers and engineering data specific to the various mast anchors devices, refer to the most recent « **MAST ANCHOR SPECIFICATIONS** » documents available with the project quotation. You can also contact your **FRACO** representative for a copy of these documents.

## Mast anchor specifications

### Transmitted efforts

The following figures show the loads transmitted by the mast anchor to the building for the different types of mast anchors available. These loads **do not include** the safety factors that must be taken into account in accordance with the applicable local regulations. Refer to the anchor details of the specific installation quote for installation requirements. These loads include the dynamic coefficients.

The maximum horizontal load considered for a man's thrust is 45 lbf (200 N). If work tools (such as a hydrodemolition system, remote-controlled jackhammer, etc.) creates a greater thrust. This thrust must be evaluated and approved by FRACO's engineering department.

Note: Refer to the tables of the opening angles and anchor details of **PAGE 65 TO 70**

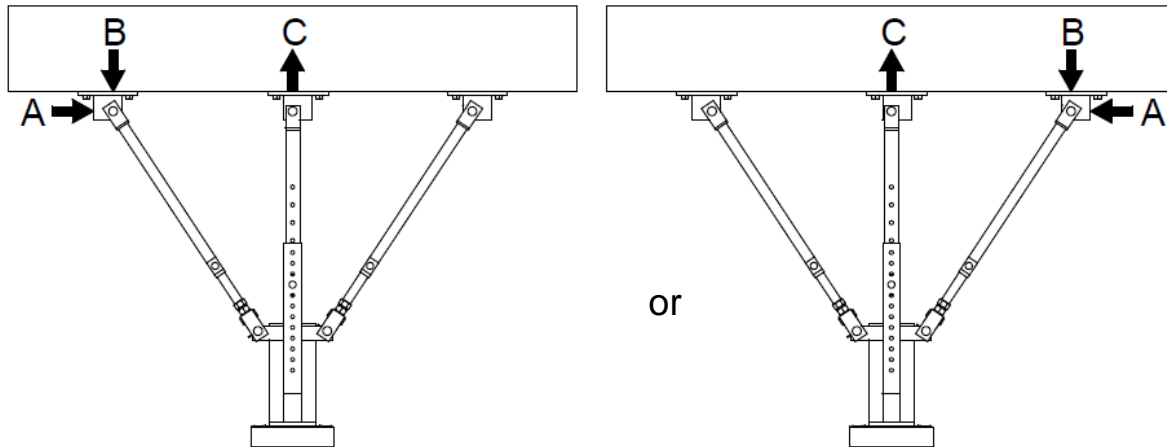
**IMPORTANT:** An engineer must confirm that the building will be able to withstand the efforts transmitted.

A = 2 500 lb (1 136 kg)

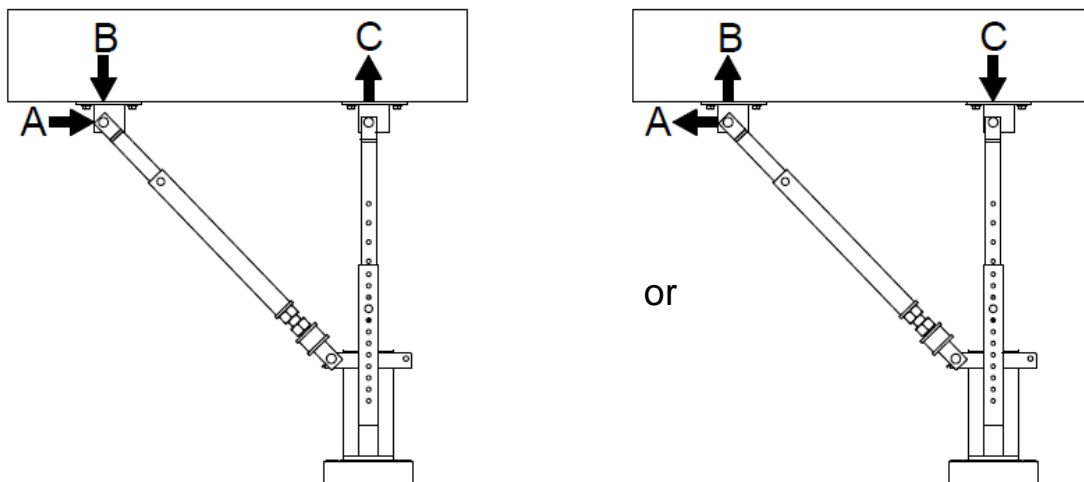
B = 4 500 lb (2 045 kg)

C = 5 500 lb (2 500 kg)

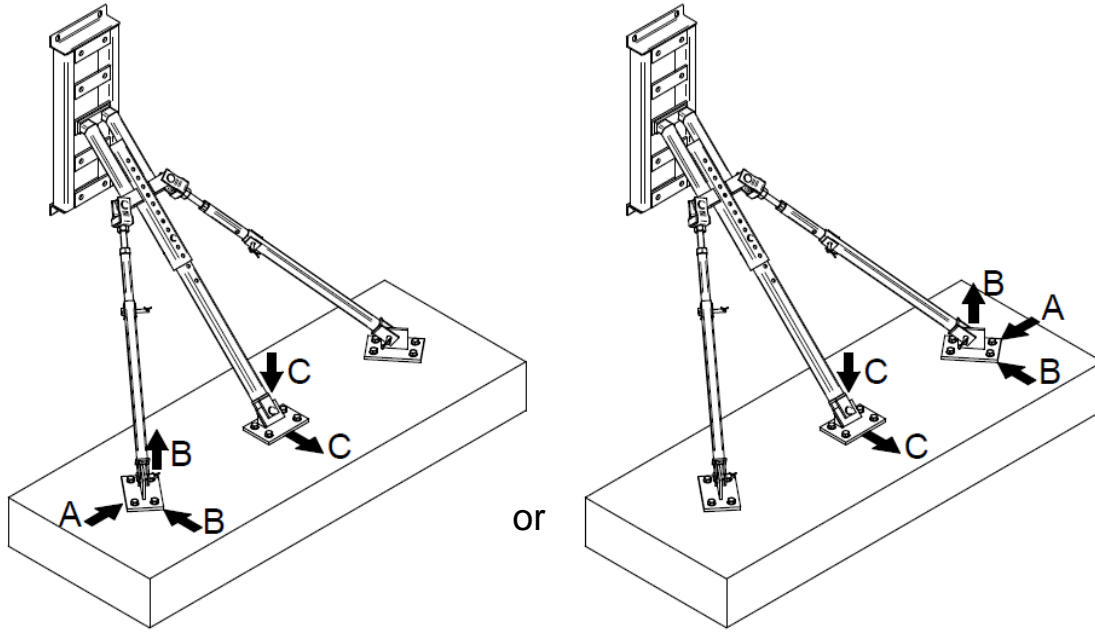
### 3-point mast anchor - vertical surface



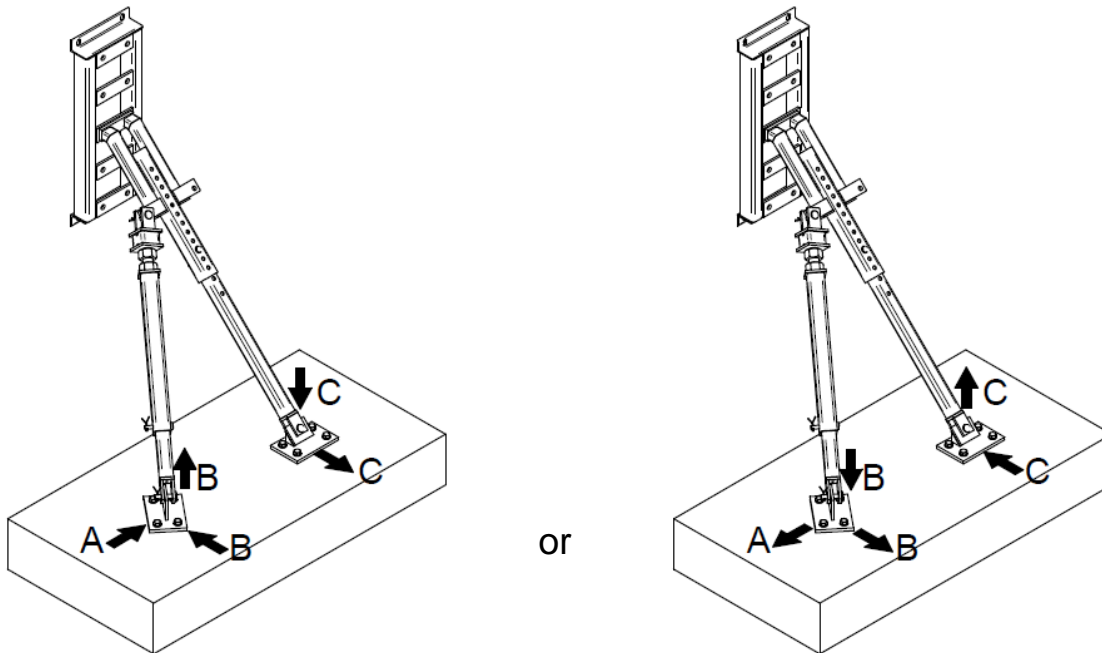
### 2-point mast anchor - vertical surface



*3-point mast anchor - horizontal surface*



*2-point mast anchor - horizontal surface*

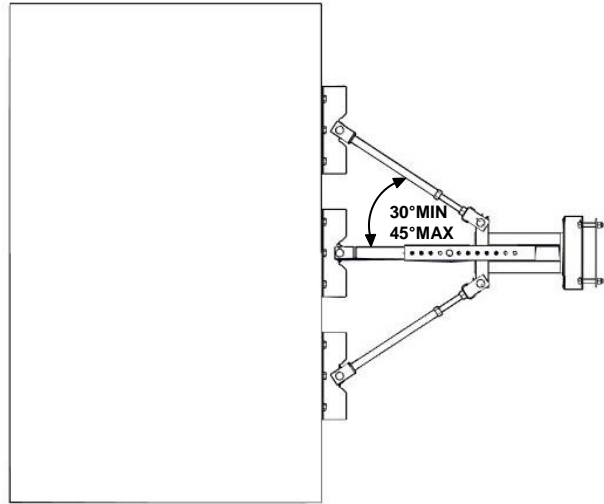
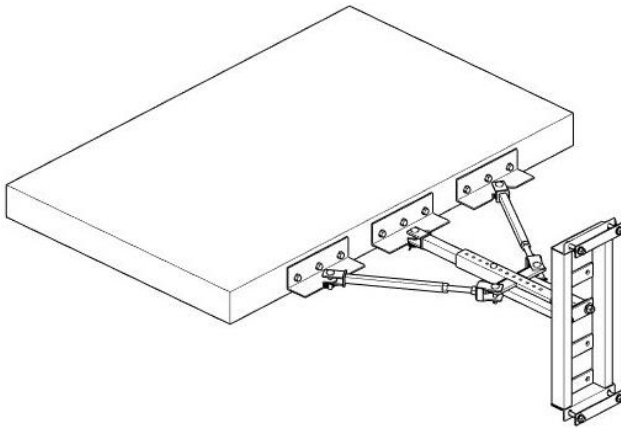




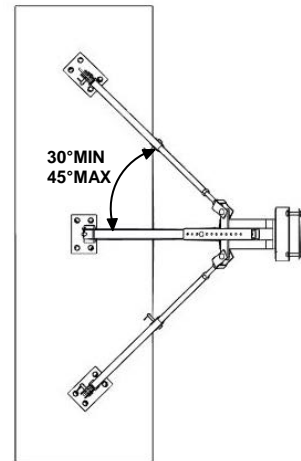
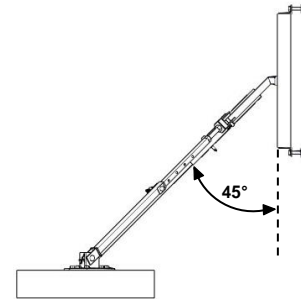
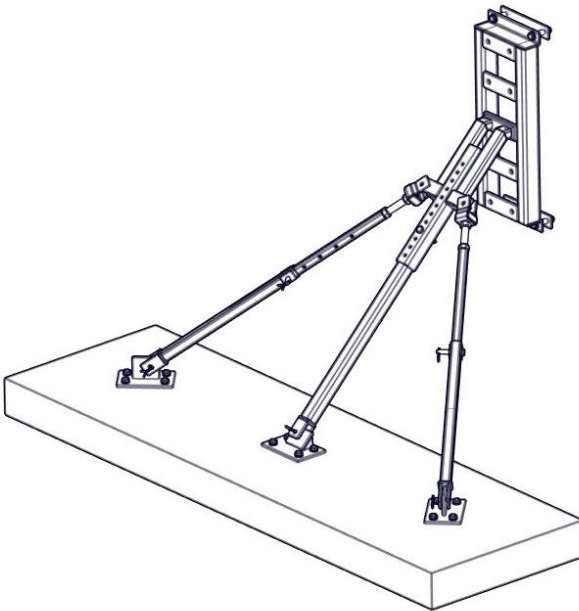
### Mast anchor opening constraints

The installation distance between the « D » anchor centres is calculated based on the opening angle and the distance between the anchor wall and the « H » mast.

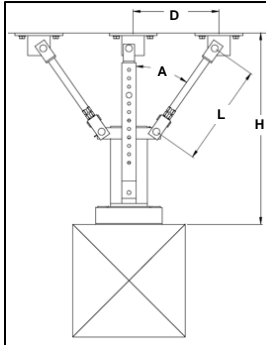
#### Horizontal attach system - Vertical anchor surface



#### 45° inclined attach system - Horizontal anchor surface



Three (3) point horizontal anchors - Composition of the mast attach



- A: Turnbuckle opening angle
- H: Distance from wall face
- D: Distance between the anchor plates
- L: Length of assembled turnbuckle

All anchors are composed of a wall attachment, a central tube and two (2) turnbuckle assemblies. The tables show the MIN/MAX dimensions for the different turnbuckle options.

**Note:** For higher H dimensions, contact the FRACO engineering department

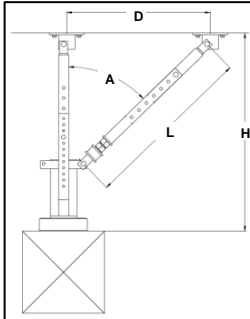
**Example:**

	COMPONENTS ACCEPTANCE	Item #	Qty
	2'-0" central tube	22010027	1
Turnbuckle option (0)	14" assembled turnbuckle	23070114	2
Turnbuckle option (1)	18" assembled turnbuckle	23070147	2
Turnbuckle option (2)	2'-0" assembled turnbuckle	23070147	2

		COMPONENTS ACCEPTANCE	Item #	Qty
		6" central tube	22020039	1
(0)		14" assembled turnbuckle	23070114	2
		H      D      L		
(0)	A=30°	MIN/ MAX	N/A	N/A
(0)	A=45°	MIN/ MAX	19" (482 mm)	13" (330 mm) 14-1/4" (362 mm)
		COMPONENTS ACCEPTANCE	Item #	Qty
		15" central tube	22020028	1
		14" assembled turnbuckle	23070114	2
		H      D      L		
(0)	A=30°	MIN/ MAX	22" (560 mm)	10,54" (268 mm) 15,08" (383 mm)
(0)	A=45°	MIN/ MAX	21" (535 mm) 22" (560 mm)	15,06" (382 mm) 17,06" (433 mm) 16,06" (408 mm) 18,47" (470 mm)
		COMPONENTS ACCEPTANCE	Item #	Qty
		15" central tube	22020028	1
(0)		14" assembled turnbuckle	23070114	2
(1)		18" assembled turnbuckle	23070147	2
		H      D      L		
(0)	A=30°	MIN/ MAX	29" (736 mm)	12,17" (310 mm) 15,08" (383 mm)
(0)	A=45°	MIN/ MAX	26" (660 mm) 29" (736 mm)	14,70" (375 mm) 14,25" (362 mm) 17,70" (450 mm) 18,50" (470 mm)
(1)	A=45°	MIN/ MAX	30" (762 mm)	18,70" (475 mm) 20" (508 mm)

		COMPONENTS ACCEPTANCE	Item #	Qty
		2'-0" central tube	22010027	1
(0)		14" assembled turnbuckle	23070114	2
(1)		18" assembled turnbuckle	23070147	2
(2)		2'-0" assembled turnbuckle	23070147	2
		H      D      L		
(0)	A=30°	MIN/ MAX	34" (864 mm) 35" (890 mm)	13,5" (343 mm) 14" (355 mm)
(1)	A=30°	MIN/ MAX	36" (915 mm) 39" (990 mm)	14,58" (370 mm) 16,30" (414 mm)
(1)	A=45°	MIN/ MAX	34" (864 mm) 35" (890 mm)	19,70" (500 mm) 20,70" (526 mm)
(2)	A=30°	MIN/ MAX	40" (1,02 m) 50" (1,27 m)	16,90" (430 mm) 22,66" (575 mm)
(2)	A=45°	MIN/ MAX	36" (915 mm) 44" (1,12 m)	21,70" (551 mm) 29,70" (755 mm)
		COMPONENTS ACCEPTANCE	Item #	Qty
		3'-0" central tube	22010049	1
(0)		2'-0" assembled turnbuckle	23070125	2
(1)		3'-1" assembled turnbuckle	23070013	2
		H      D      L		
(0)	A=30°	MIN/ MAX	46" (1,17 m) 50" (1,27 m)	20,35" (517 mm) 22,66" (575 mm)
(1)	A=30°	MIN/ MAX	52" (1,32 m) 62" (1,57 m)	23,82" (605 mm) 29,60" (752 mm)
(1)	A=45°	MIN/ MAX	46" (1,17 m) 62" (1,57 m)	31,70" (805 mm) 47,70" (1,21 m)
		COMPONENTS ACCEPTANCE	Item #	Qty
		4'-0" central tube	22010050	1
(0)		3'-1" assembled turnbuckle	23070013	2
		H      D      L		
(0)	A=30°	MIN/ MAX	63" (1,60 m) 73" (1,85 m)	30,17" (766 mm) 36" (915 mm)
(0)	A=45°	MIN/ MAX	58" (1,50 m) 63" (1,60 m)	43,70" (1,11 m) 48,70" (1,25 m)

Two (2) point horizontal anchors - Composition of the mast attach



- A: Turnbuckle opening angle
- H: Distance from wall face
- D: Distance between the anchor plates
- L: Length of assembled turnbuckle

Note: For higher H dimensions, contact the FRACO engineering department

All anchors are composed of a wall attachment, a central tube and one (1) turnbuckle assembly. The tables show the MIN/MAX dimensions for the different turnbuckle options.

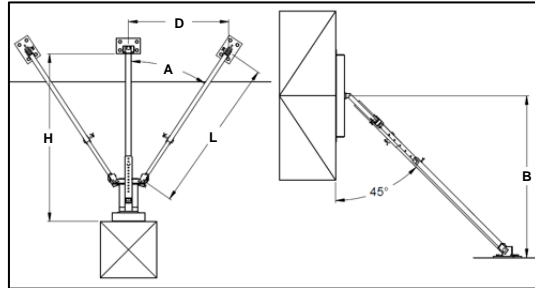
Example:

	COMPONENTS ACCEPTANCE	Item #	Qty
Turnbuckle option (0)	2'-0" central tube	22010027	1
Turnbuckle option (1)	14" assembled turnbuckle	23070114	2
Turnbuckle option (2)	18" assembled turnbuckle	23070147	2
Turnbuckle option (2)	2'-0" assembled turnbuckle	23070147	2

		COMPONENTS ACCEPTANCE	Item #	Qty		
Wall Attachment 2'-3" (21490017)	(0)	2'-0" central tube	22010027	1		
		2'-7" reinforced turnbuckle +	23070103	1		
		2'-0" central tube	22010027	1		
	(0)	H D L				
		A=30°	MIN/MAX	N/A	N/A	N/A
		A=45°	MIN	49" (1,25 m)	34,70" (880 mm)	42,16" (1,07 m)
	(0)	A=45°	MAX	50" (1,27 m)	35,70" (907 mm)	43,57" (1,10 m)
		(1)				
	Wall Attachment 2'-3" (21490017)	(0)	3'-0" central tube	22010049	1	
			2'-7" turnbuckle +	23070103	1	
			2'-0" central tube	22010027	1	
(1)		2'-7" turnbuckle +	23070103	1		
		3'-0" central tube	22010049	1		
(0)		H D L				
		A=30°	MIN	56" (1,42 m)	26,13" (664 mm)	42,50" (1,08 m)
		MAX	62" (1,58 m)	29,60" (752 mm)	49,50" (1,25 m)	
(0)		A=45°	MIN	49" (1,25 m)	34,70" (880 mm)	42,16" (1,07 m)
			MAX	57" (1,45 m)	42,70" (1,08 m)	53,50" (1,35 m)
		(1)	A=45°	MIN	58" (1,47 m)	43,70" (1,11 m)
(1)	A=45°	MAX	62" (1,58 m)	47,70" (1,20 m)	60,55" (1,54 m)	
	(2)					
Wall Attachment 2'-3" (21490017)	(0)	4'-0" central tube	22010050	1		
		2'-7" turnbuckle +	23070103	1		
		2'-0" central tube	22010027	1		
	(1)	2'-7" turnbuckle +	23070103	1		
		3'-0" central tube	22010049	1		
		2'-7" turnbuckle +	23070103	1		
	(2)	4'-0" central tube	22010050	1		
	(0)	H D L				
		A=30°	MIN	58" (1,47 m)	27,28" (693 mm)	44,82" (1,14 m)
		MAX	65" (1,65 m)	31,32" (795 mm)	52,90" (1,35 m)	
(1)	A=30°	MIN	66" (1,68 m)	31,90" (810 mm)	54" (1,37 m)	
		MAX	74" (1,88 m)	36,50" (928 m)	63,30" (1,60 m)	
	(1)	A=45°	MIN	58" (1,47 m)	43,70" (1,11 m)	54,90" (1,40 m)
(2)	A=45°	MAX	65" (1,65 m)	50,70" (1,29 m)	64,80" (1,65 m)	
		MIN	66" (1,68 m)	51,70" (1,30 m)	66,20" (1,68 m)	
	MAX	74" (1,88 m)	59,70" (1,52 m)	77,52" (2,00 m)		

		COMPONENTS ACCEPTANCE	Item #	Qty	
Wall attachment 2'-3" (21490017)	(0)	5'-0" central tube	22010061	1	
		2'-7" turnbuckle +	23070103	1	
		3'-0" central tube	22010049	1	
	(1)	2'-7" turnbuckle +	23070103	1	
		4'-0" central tube	22010050	1	
		2'-7" turnbuckle +	23070103	1	
	(2)	5'-0" central tube	22010061	1	
		2'-7" turnbuckle +	23070103	1	
		6'-0" reinforced central tube	22030074	1	
	(3)	2'-7" turnbuckle +	23070103	1	
		6'-0" reinforced central tube	22030074	1	
(0)	H D L				
	A=30°	MIN	70" (1,78 m)	34,20" (869 mm)	58,67" (1,50 m)
	MAX	76" (1,93 m)	37,68" (957 mm)	65,60" (1,67 m)	
(1)	A=30°	MIN	77" (1,96 m)	38,25" (972 mm)	66,75" (1,70 m)
		MAX	86" (2,18 m)	43,45" (1,10 m)	77,15" (1,96 m)
	(1)	A=45°	MIN	70" (1,78 m)	55,70" (1,40 m)
(2)	A=45°	MAX	74" (1,88 m)	59,70" (1,52 m)	77,52" (1,97 m)
		MIN	75" (1,90 m)	60,70" (1,55 m)	78,93" (2,00 m)
	(2)	A=45°	MAX	82" (2,08 m)	67,70" (1,72 m)
(3)	A=45°	MIN	83" (2,10 m)	68,70" (1,75 m)	90,25" (2,30 m)
		MAX	86" (2,18 m)	71,70" (1,82 m)	94,50" (2,40 m)
Wall attachment 2'-3" (21490017)	(0)	5'-0" central tube	22010061	1	
		2'-7" turnbuckle +	23070103	1	
		4'-0" central tube	22010050	1	
	(1)	2'-7" turnbuckle +	23070103	1	
		5'-0" central tube	22010061	1	
		2'-7" turnbuckle +	23070103	1	
	(2)	6'-0" reinforced central tube	22030074	1	
		2'-7" turnbuckle +	23070103	1	
		7'-0" reinforced central tube	22030085	1	
	(3)				
(0)	H D L				
	A=30°	MIN	85" (2,16 m)	42,87" (1,09 m)	76" (1,93 m)
	MAX	86" (2,18 m)	43,45" (1,10 m)	77,15" (1,96 m)	
(1)	A=30°	MIN	87" (2,21 m)	44,03" (1,12 m)	78,30" (2,00 m)
		MAX	97" (2,46 m)	49,80" (1,25 m)	89,85" (2,28 m)
	(2)	A=45°	MIN	85" (2,16 m)	70,70" (1,80 m)
(3)	A=45°	MAX	91" (2,31 m)	76,70" (1,95 m)	101,56" (2,58 m)
		MIN	92" (2,34 m)	77,70" (1,97 m)	103" (2,62 m)
	MAX	98" (2,50 m)	83,70" (2,13 m)	111,50" (2,83 m)	

45° inclined three (3) point anchors - Composition of the mast attach



- A: Turnbuckle opening angle
- H: Distance from wall face
- D: Distance between the anchor plates
- L: Length of assembled turnbuckle
- B: Attachment height

All anchors are composed of a wall fixture, a central tube and two (2) turnbuckle assemblies. The tables show the MIN/MAX dimensions for the different turnbuckle options. Example:

Note: For higher H dimensions, contact the FRACO engineering department

Turnbuckle option (0)  
Turnbuckle option (1)  
Turnbuckle option (2)

COMPONENTS ACCEPTANCE	Item #	Qty
2'-0" central tube	22010027	1
14" assembled turnbuckle	23070114	2
18" assembled turnbuckle	23070147	2
2'-0" assembled turnbuckle	23070147	2

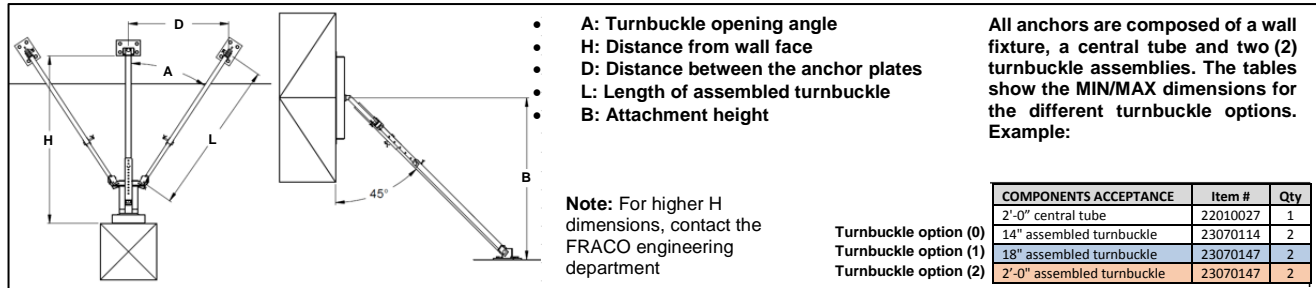
		COMPONENTS ACCEPTANCE		Item #	Qty	
		2'-0" central tube		22010027	1	
(0)		14" turnbuckle		23070114	2	
(1)		18" turnbuckle		23070147	2	
(2)		2'-0" turnbuckle		23070125	2	
(3)		3'-1" turnbuckle		23070013	2	
		H	D	L	B	
(0)	A=30°	MIN	24" (610 mm)	13,31" (338 mm)	16,87" (428 mm)	21,95" (558 mm)
		MAX	25" (635 mm)	14,13" (360 mm)	18,50" (470 mm)	22,95" (583 mm)
(1)	A=30°	MIN	26" (660 mm)	14,95" (380 mm)	20,13" (511 mm)	23,95" (608 mm)
		MAX	27" (686 mm)	15,75" (400 mm)	21,77" (553 mm)	24,95" (634 mm)
(2)	A=30°	MIN	29" (737 mm)	17,40" (442 mm)	25,00" (635 mm)	26,95" (685 mm)
		MAX	34" (864 mm)	21,50" (546 mm)	33,20" (843 mm)	31,95" (812 mm)
(1)	A=45°	MIN	24" (610 mm)	19,50" (495 mm)	20,66" (525 mm)	21,95" (558 mm)
		MAX	25" (635 mm)	20,90" (531 mm)	22,66" (575 mm)	22,95" (583 mm)
(2)	A=45°	MIN	26" (660 mm)	22,32" (567 mm)	24,66" (626 mm)	23,95" (608 mm)
		MAX	31" (787 mm)	29,40" (747 mm)	34,66" (880 mm)	28,95" (735 mm)
(3)	A=45°	MIN/MAX	34" (864 mm)	33,63" (854 mm)	40,66" (1,03 m)	91,95" (2,33 mm)
		COMPONENTS ACCEPTANCE		Item #	Qty	
		3'-0" central tube		22010049	1	
(0)		2'-0" turnbuckle		23070125	2	
(1)		3'-1" turnbuckle		23070013	2	
		H	D	L	B	
(0)	A=30°	MIN	34" (864 mm)	21,50" (546 mm)	33,20" (843 mm)	31,95" (812 mm)
		MAX	35" (889 mm)	22,30" (566 mm)	34,83" (885 mm)	32,95" (837 mm)
(1)	A=30°	MIN	37" (840 mm)	23,93" (608 mm)	38,10" (968 mm)	34,95" (888 mm)
		MAX	43" (1,09 m)	28,83" (732 mm)	47,90" (1,22 m)	40,95" (1,04 m)
(1)	A=45°	MIN	34" (864 mm)	33,63" (854 mm)	40,66" (1,03 m)	91,95" (812 mm)
		MAX	43" (1,09 m)	46,36" (1,18 m)	58,66" (1,50 m)	40,95" (1,04 m)
		COMPONENTS ACCEPTANCE		Item #	Qty	
		4'-0" central tube		22010050	1	
(0)		3'-1" turnbuckle		23070013	2	
(1)		3'-1" turnbuckle + 15-1/8" turnbuckle ext.		23070013 23040010	2 2	
		H	D	L	B	
(0)	A=30°	MIN	40" (1,02 m)	26,38" (670 mm)	43,00" (1,09 m)	37,95" (964 mm)
		MAX	51" (1,30 m)	35,36" (898 mm)	60,96" (1,55 m)	48,95" (1,24 m)
(0)	A=45°	MIN	40" (1,02 m)	42,12" (1,07 m)	52,66" (1,34 m)	37,95" (964 mm)
		MAX	45" (1,14 m)	49,20" (1,25 m)	62,66" (1,60 m)	42,95" (1,09 m)
(1)	A=45°	MIN	46" (1,17 m)	50,60" (1,28 m)	64,66" (1,64 m)	43,95" (1,12 m)
		MAX	51" (1,30 m)	57,67" (1,46 m)	74,66" (1,90 m)	48,95" (1,24 m)

Angled wall attachment (21490051)

		COMPONENTS ACCEPTANCE		Item #	Qty	
		5'-0" central tube		22010061	1	
(0)		3'-1" turnbuckle		23070013	2	
(1)	A=30°	3'-1" turnbuckle	23070013	2		
		15-1/8" turnbuckle ext. +	23040010	2		
(2)	A=30°	3'-1" turnbuckle	23070013	2		
		2'-3" turnbuckle ext. +	23040032	2		
(3)	A=30°	3'-1" turnbuckle + 3'-3" turnbuckle ext.	23070013 23040021	2 2		
		H	D	L	B	
(0)	A=30°	MIN	48" (1,22 m)	32,91" (836 mm)	56,06" (1,42 m)	45,95" (1,17 m)
		MAX	52" (1,32 m)	36,18" (919 mm)	62,59" (1,59 m)	49,95" (1,27 m)
(1)	A=30°	MIN	53" (1,35 m)	37,00" (940 mm)	64,22" (1,63 m)	50,95" (1,30 m)
		MAX	59" (1,50 m)	41,89" (1,06 m)	74,02" (1,88 m)	56,95" (1,45 m)
(2)	A=30°	MIN/MAX	60" (1,52 m)	42,71" (1,08 m)	75,66" (1,92 m)	57,95" (1,47 m)
(1)	A=45°	MIN	48" (1,22 m)	53,43" (1,36 m)	68,66" (1,74 m)	45,95" (1,17 m)
		MAX	51" (1,30 m)	57,67" (1,46 m)	74,66" (1,90 m)	48,95" (1,24 m)
(2)	A=45°	MIN	52" (1,32 m)	59,09" (1,50 m)	76,66" (1,95 m)	49,95" (1,27 m)
		MAX	57" (1,45 m)	66,16" (1,68 m)	86,66" (2,20 m)	54,95" (1,40 m)
(3)	A=45°	MIN	58" (1,47 m)	67,57" (1,72 m)	88,66" (2,25 m)	55,95" (1,42 m)
		MAX	60" (1,52 m)	70,40" (1,79 m)	92,66" (2,35 m)	57,95" (1,47 m)
		COMPONENTS ACCEPTANCE		Item #	Qty	
		6'-0" central tube		22030074	1	
(0)		3'-1" turnbuckle		23070013	2	
(1)	A=30°	3'-1" turnbuckle	23070013	2		
		15-1/8" turnbuckle ext. +	23040010	2		
(2)	A=30°	3'-1" turnbuckle	23070013	2		
		2'-3" turnbuckle ext. +	23040032	2		
(3)	A=30°	3'-1" turnbuckle	23070013	2		
		15-1/8" turnbuckle ext. + 3'-3" turnbuckle ext. +	23040010 23040021	2 2		
		H	D	L	B	
(0)	A=30°	MIN/MAX	59" (1,50 m)	41,89" (1,06 m)	74,02" (1,88 m)	56,95" (1,45 m)
		MIN	60" (1,52 m)	42,71" (1,08 m)	75,66" (1,92 m)	57,95" (1,47 m)
(1)	A=30°	MAX	67" (1,70 m)	48,42" (1,23 m)	87,09" (2,21 m)	64,95" (1,65 m)
		MIN/MAX	68" (1,73 m)	49,25" (1,25 m)	88,72" (2,25 m)	65,95" (1,67 m)
(2)	A=30°	MIN	59" (1,50 m)	67,00" (1,70 m)	90,66" (2,30 m)	56,95" (1,45 m)
		MAX	63" (1,60 m)	74,65" (1,90 m)	98,66" (2,50 m)	60,95" (1,55 m)
(3)	A=45°	MIN	64" (1,62 m)	76,06" (1,93 m)	100,66" (2,56 m)	61,95" (1,57 m)
		MAX	68" (1,73 m)	81,71" (2,07 m)	108,66" (2,76 m)	65,95" (1,67 m)

Angled wall attachment (21490051)

45° inclined three (3) point anchors - Composition of the mast attach (CONTINUED)

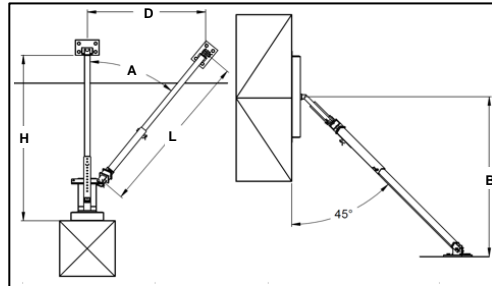


COMPONENTS ACCEPTANCE	Item #	Qty
2'-0" central tube	22010027	1
14" assembled turnbuckle	23070114	2
18" assembled turnbuckle	23070147	2
2'-0" assembled turnbuckle	23070147	2

Turnbuckle option (0)  
 Turnbuckle option (1)  
 Turnbuckle option (2)

		COMPONENTS ACCEPTANCE	Item #	Qty		
Angled wall attachment (21490051)	(0)	7'-0" central tube	22030085	1		
		3'-1" turnbuckle	23070013	2		
	(1)	2'-3" turnbuckle ext. +	23040032	2		
		3'-1" turnbuckle	23070013	2		
	(2)	3'-3" turnbuckle ext. +	23040021	2		
		3'-1" turnbuckle	23070013	2		
	(3)	15'-1/8" turnbuckle ext. +	23040010	2		
		3'-3" turnbuckle ext. +	23040021	2		
	(4)	3'-1" turnbuckle	23070013	2		
		2'-3" turnbuckle ext. +	23040032	2		
				H	D	L
(0)	A=30°	MIN/MAX	67" (1,70 m)	48,42" (1,23 m)	87,09" (2,21 m)	64,95" (1,65 m)
		MIN	68" (1,73 m)	49,25" (1,25 m)	88,72" (2,25 m)	65,95" (1,67 m)
(1)	A=30°	MAX	74" (1,88 m)	54,15" (1,37 m)	98,52" (2,50 m)	71,95" (1,83 m)
		MIN	75" (1,90 m)	54,96" (1,40 m)	100,15" (2,54 m)	72,95" (1,85 m)
(2)	A=30°	MAX	77" (1,96 m)	56,60" (1,44 m)	103,42" (2,63 m)	74,95" (1,90 m)
		MIN	67" (1,70 m)	80,30" (2,04 m)	106,66" (2,71 m)	64,95" (1,65 m)
(3)	A=45°	MAX	69" (1,75 m)	83,13" (2,11 m)	110,66" (2,81 m)	66,95" (1,70 m)
		MIN	70" (1,78 m)	84,54" (2,15 m)	112,66" (2,86 m)	67,95" (1,73 m)
(4)	A=45°	MAX	75" (1,90 m)	91,61" (2,33 m)	122,66" (3,12 m)	72,95" (1,85 m)
		MIN	76" (1,93 m)	93,03" (2,36 m)	124,66" (3,17 m)	73,95" (1,88 m)
		MAX	77" (1,96 m)	94,44" (2,40 m)	126,66" (3,22 m)	74,95" (1,90 m)

45° inclined two (2) point anchors - Composition of the mast attach



- A: Turnbuckle opening angle
- H: Distance from wall face
- D: Distance between the anchor plates
- L: Length of assembled turnbuckle
- B: Attachment height

All anchors are composed of a wall attachment, a central tube and one (1) turnbuckle assembly. The tables show the MIN/MAX dimensions for the different turnbuckle options. Example:

**Note:** For higher H dimensions, contact the FRACO engineering department

Turnbuckle option (0)  
Turnbuckle option (1)  
Turnbuckle option (2)

COMPONENTS ACCEPTANCE	Item #	Qty
2'-0" central tube	22010027	1
14" assembled turnbuckle	23070114	2
18" assembled turnbuckle	23070147	2
2'-0" assembled turnbuckle	23070147	2

		COMPONENTS ACCEPTANCE	Item #	Qty	
(0)		3'-0" central tube	22010049	1	
		2'-7" reinforced turnbuckle +	23070103	1	
(1)		2'-0" central tube	22010027	1	
		2'-7" reinforced turnbuckle +	23070103	1	
		3'-0" central tube	22010049	1	
		H	D	L	B
(0)	A=30°	MIN 40" (1,02 m)	26,38" (670 mm)	43" (1,09 m)	37,95" (964 mm)
		MAX 43" (1,09 m)	28,83" (732 mm)	47,89" (1,22 m)	40,95" (1,04 m)
(0)	A=45°	MIN 35" (889 mm)	35,04" (1,04 m)	42,66" (1,08 m)	32,95" (837 mm)
		MAX 40" (1,02 m)	42,12" (1,07 m)	52,66" (1,34 m)	37,95" (964 mm)
(1)	A=45°	MIN 41" (1,04 m)	43,53" (1,10 m)	54,66" (1,39 m)	38,95" (989 mm)
		MAX 43" (1,09 mm)	46,36" (1,18 m)	58,66" (1,50 m)	40,95" (1,04 m)
		COMPONENTS ACCEPTANCE	Item #	Qty	
(0)		4'-0" central tube	22010050	1	
		2'-7" reinforced turnbuckle +	23070103	1	
		2'-0" central tube	22010027	1	
(1)		2'-7" reinforced turnbuckle +	23070103	1	
		3'-0" central tube	22010049	1	
(2)		2'-7" reinforced turnbuckle +	23070103	1	
		4'-0" central tube	22010050	1	
		H	D	L	B
(0)	A=30°	MIN 40" (1,02 m)	26,38" (670 mm)	43" (1,09 m)	37,95" (964 mm)
		MAX 46" (1,17 m)	31,28" (795 mm)	52,79" (1,34 m)	43,95" (1,12 m)
(1)	A=30°	MIN 47" (1,20 m)	32,09" (815 mm)	54,43" (1,38 m)	44,95" (1,14 m)
		MAX 51" (1,30 m)	35,36" (898 mm)	60,96" (1,55 m)	48,95" (1,25 m)
	A=45°	MIN/MAX 40" (1,02 m)	42,12" (1,07 m)	52,66" (1,34 m)	37,95" (964 mm)
(1)	A=45°	MIN 41" (1,04 m)	43,53" (1,10 m)	54,66" (1,39 m)	38,95" (989 mm)
		MAX 46" (1,17 m)	50,60" (1,27 m)	64,66" (1,64 m)	43,95" (1,12 m)
(2)	A=45°	MIN 47" (1,20 m)	52,00" (1,32 m)	66,66" (1,70 m)	44,95" (1,14 m)
		MAX 51" (1,30 m)	57,67" (1,46 m)	74,66" (1,90 m)	48,95" (1,25 m)

Angled wall attachment (21490051)

		COMPONENTS ACCEPTANCE	Item #	Qty	
(0)		5'-0" central tube	22010061	1	
		2'-7" reinforced turnbuckle +	23070103	1	
		3'-0" central tube	22010049	1	
(1)		2'-7" reinforced turnbuckle +	23070103	1	
		4'-0" central tube	22010050	1	
(2)		2'-7" reinforced turnbuckle +	23070103	1	
		5'-0" central tube	22010061	1	
(3)		2'-7" reinforced turnbuckle +	23070103	1	
		6'-0" central tube	22030074	1	
		H	D	L	B
(0)	A=30°	MIN 48" (1,22 m)	32,91" (836 mm)	56,06" (1,42 m)	45,95" (1,17 m)
		MAX 54" (1,37 m)	37,81" (960 mm)	65,86" (1,67 m)	51,95" (1,32 m)
(1)	A=30°	MIN 55" (1,40 m)	38,63" (981 mm)	67,50" (1,71 m)	52,95" (1,34 m)
		MAX 60" (1,52 m)	42,71" (1,08 m)	75,66" (1,92 m)	57,95" (1,47 m)
(1)	A=45°	MIN 48" (1,22 m)	53,43" (1,36 m)	68,66" (1,74 m)	45,95" (1,17 m)
		MAX 52" (1,32 m)	59,09" (1,50 m)	76,66" (1,95 m)	49,95" (1,27 m)
(2)	A=45°	MIN 53" (1,35 m)	60,50" (1,54 m)	78,66" (2,00 m)	50,95" (1,30 m)
		MAX 58" (1,47 m)	67,57" (1,72 m)	88,66" (2,25 m)	55,95" (1,42 m)
(3)	A=45°	MIN 59" (1,50 m)	69,00" (1,75 m)	90,66" (2,30 m)	56,95" (1,45 m)
		MAX 60" (1,52 m)	70,40" (1,79 m)	92,66" (2,35 m)	57,95" (1,47 m)
		COMPONENTS ACCEPTANCE	Item #	Qty	
(0)		6'-0" reinforced central tube	22030074	1	
		2'-7" reinforced turnbuckle +	23070103	1	
		4'-0" central tube	22010050	1	
(1)		2'-7" reinforced turnbuckle +	23070103	1	
		5'-0" central tube	22010061	1	
(2)		2'-7" reinforced turnbuckle +	23070103	1	
		6'-0" reinforced central tube	22030074	1	
(3)		2'-7" reinforced turnbuckle +	23070103	1	
		7'-0" reinforced central tube	22030085	1	
		H	D	L	B
(0)	A=30°	MIN 59" (1,50 m)	41,89" (1,06 m)	74,02" (1,88 m)	56,95" (1,45 m)
		MAX 61" (1,55 m)	43,52" (1,11 m)	77,29" (1,96 m)	58,95" (1,50 m)
(1)	A=30°	MIN 62" (1,57 m)	44,34" (1,13 m)	78,92" (2,00 m)	59,95" (1,52 m)
		MAX 68" (1,73 m)	49,25" (1,25 m)	88,72" (2,25 m)	65,95" (1,67 m)
(2)	A=45°	MIN 59" (1,50 m)	69,00" (1,75 m)	90,66" (2,30 m)	56,95" (1,45 m)
		MAX 64" (1,62 m)	76,06" (1,93 m)	100,66" (2,56 m)	61,95" (1,57 m)
(3)	A=45°	MIN 65" (1,65 m)	77,47" (1,97 m)	102,66" (2,61 m)	62,95" (1,60 m)
		MAX 68" (1,73 m)	81,71" (2,06 m)	108,66" (2,76 m)	65,95" (1,67 m)

Angled wall attachment (21490051)

45° inclined two (2) point anchors - Composition of the mast attach (CONTINUED)

- **A:** Turnbuckle opening angle
- **H:** Distance from wall face
- **D:** Distance between the anchor plates
- **L:** Length of assembled turnbuckle
- **B:** Attachment height

**Note:** For higher H dimensions, contact the FRACO engineering department

All anchors are composed of a wall attachment, a central tube and one (1) turnbuckle assembly. The tables show the MIN/MAX dimensions for the different turnbuckle options. Example:

COMPONENTS ACCEPTANCE	Item #	Qty
2'-0" central tube	22010027	1
14" assembled turnbuckle	23070114	2
18" assembled turnbuckle	23070147	2
2'-0" assembled turnbuckle	23070147	2

Turnbuckle option (0)  
Turnbuckle option (1)  
Turnbuckle option (2)

		COMPONENTS ACCEPTANCE	Item #	Qty
Angled wall attachment (21490051)	(0)	7'-0" reinforced central tube	22030085	1
		2'-7" reinforced turnbuckle +	23070103	1
		5'-0" central tube	22010061	1
	(1)	2'-7" reinforced turnbuckle +	23070103	1
		6'-0" reinforced central tube	22030074	1
	(2)	2'-7" reinforced turnbuckle +	23070103	1
		7'-0" reinforced central tube	22030085	1
	(3)	2'-7" reinforced turnbuckle +	23070103	1
		8'-0" reinforced central tube	22030096	1

		H	D	L	B	
(0)	A=30°	MIN	67" (1,70 m)	48,42" (1,23 m)	87,09" (2,21 m)	64,95" (1,65 m)
		MAX	68" (1,73 m)	49,25" (1,25 m)	88,72" (2,25 m)	65,95" (1,67 m)
(1)	A=30°	MIN	69" (1,75 m)	50,06" (1,27 m)	90,35" (2,30 m)	66,95" (1,70 m)
		MAX	76" (1,93 m)	55,77" (1,42 m)	101,78" (1,59 m)	73,95" (1,88 m)
(2)	A=30°	MIN/MAX	77" (1,96 m)	56,59" (1,44 m)	103,42" (2,63 m)	74,95" (1,90 m)
(2)	A=45°	MIN	67" (1,70 m)	80,30" (2,04 m)	106,66" (2,71 m)	64,95" (1,65 m)
		MAX	70" (1,78 m)	84,54" (2,15 m)	112,66" (2,86 m)	67,95" (1,73 m)
(3)	A=45°	MIN	71" (1,80 m)	85,96" (2,18 m)	114,66" (2,91 m)	68,95" (1,75 m)
		MAX	76" (1,93 m)	93,03" (2,36 m)	124,66" (3,17 m)	73,95" (1,88 m)

## Installation of the mast attach device (typical)

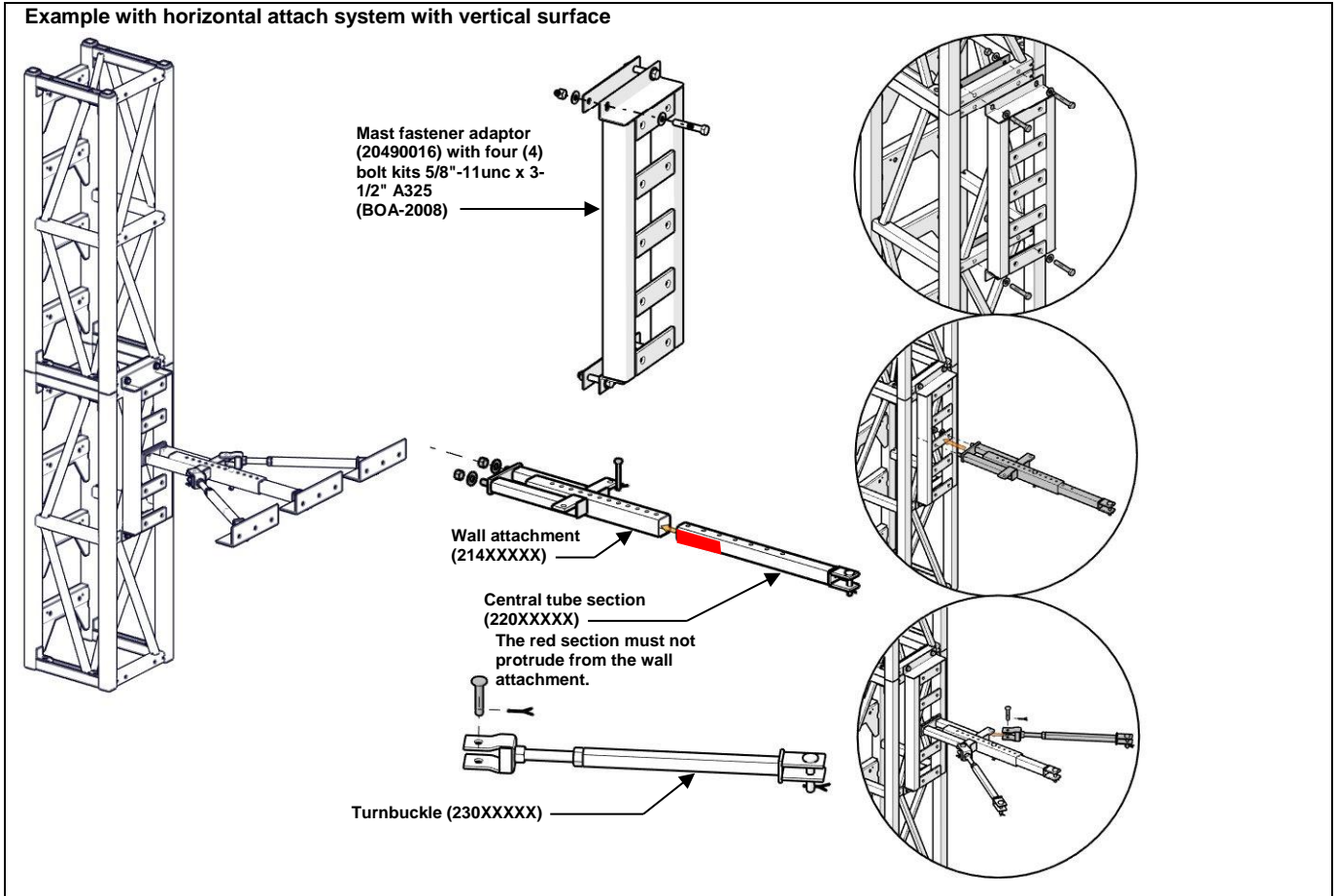


Figure 74 - Installation of attach system on to mast







## Lifting unit operation specifications

### IMPORTANT! Reminders - Operation specifications

- In the « out of service » condition, the platform, with its balanced load on each side, must always be located between two (2) levels, at equal distance from the mast anchor devices, and lowered to ground level.
- The typical distance between each mast anchor is 31'-0" (9.5 m) ± 5'-0" (1,5 m). This distance must be respected from the first or second anchor depending on the type of base used, refer to the **INSTALLATION/DISMANTLING OF MAST SECTIONS, ON PAGE 73**.
- Positioning of the unit in relation to the highest anchor:
  - The level of the highest anchorage can be exceeded by a height of 5'-0" (1,5 m) when the unit is in normal operational mode. This permission is also valid for a unit equipped with a portable crane system, or a monorail system, provided that these systems are not in operation (not loaded).
  - It is **forbidden** to exceed the level of the highest anchorage when the lifting unit is loaded, or equipped with a portable crane in operation (loaded) or monorail system in operation (loaded), or with a winter shelter accessory or a rigid roof.
- It is **forbidden** to cover guardrails and platforms with plywood (vertical faces) or to extend the guardrails without the consent of FRACO.
- Observe the maximum wind conditions:
  - [0 to 28 mph] (0 to 45 km/h): Installation wind condition
  - [0 to 34 mph] (0 to 55 km/h): In service wind condition
  - [34 to 102 mph] (55 to 165 km/h): Out of service wind condition
  - [102 mph and +] (165 km/h and +): The structure requires additional reinforcement. Contact your FRACO representative.
- For use without anchorage and associated load distributions:
  - ∞ **SEE GROUND LOAD - UNIVERSAL FREESTANDING BASE (14030109), ON PAGE 35**
  - ∞ **SEE GROUND LOAD - UNIVERSAL FREESTANDING BASE (14030053), ON PAGE 36**
- The minimum penetration into the concrete wall/slab depends on the type of mast anchor and its use. FRACO shall not be held responsible for the use and choice of anchors other than those proposed in the project quote.
  - ∞ **SEE MAST ANCHOR, ON PAGE 62**
 For more information on the various mast anchors devices, refer to the most recent « **MAST ANCHOR SPECIFICATIONS** » documents available with the project quotation. You can also contact your FRACO representative for a copy of these documents.


## Installation/dismantling of mast sections

-  **IMPORTANT!** At all times during the installation and dismantling of masts and anchors, the floor of the unit shall not be more than 30'-0" (9,1 m) above the last Installed anchor (highest).
-  **IMPORTANT!** During the installation of the first two (2) anchors, on a ground base assembly only, **it is mandatory** to support the mast with independent lifting equipment (crane, crane truck or forklift truck).
-  **IMPORTANT!** In the case of a ground base installation, the platform **MUST NEVER** be elevated and/or loaded with equipment before the installation of the first two (2) mast anchors has been completed. This applies to assembly as well as the disassembly operations.
-  **IMPORTANT!** Wear a safety harness attached at all times to a regulatory attachment point during the installation and disassembly of the platform.  
∞SEE REGULATORY ATTACHMENT POINTS, ON PAGE 9

In all cases, when a mast anchor is installed or dismantled, a **maximum allowable** extension of 10'-0" (3,0 m) may be installed on either side of the lifting unit.

- Complete the 10'-0" (3,0 m) extension platforms, including plankings, guardrails and accessories, before installing the mast sections and anchors.
- During the installation of the first two mast anchors, on a ground base assembly, it is **forbidden** to load the platform.

<b>Max extension</b> 10'-0" (3,0 m)	<b>Unit</b>	<b>Max extension</b> 10'-0" (3,0 m)
--	-------------	--

-  **IMPORTANT!** Failure to follow these instructions may result in serious property damage, personal injury, and eventually death. If a situation not mentioned in this manual occurs, contact your FRACO representative.



## Installation of mast sections and anchor devices / 20K platform with ground base

### Step 1

- You may install up to a **MAXIMUM 10'-0"** (3,0 m) extension on each side of the unit during installation of the mast sections and mast anchors. Consider this as the « **Setup configuration** ».
- Install the outriggers, planking guardrails, planking attachments, guardrails, guardrail pocket holders and plankings on the lifting unit.
- Place the plankings under the location of the anchors to be installed. Install the first mast anchor at 10'-0" (3,0 m) from the ground. This height is a recommendation. For more information on the permitted installation heights for the first anchor;  
∞ SEE TABLE 1 - DIMENSIONS AND CLEARANCE, ON PAGE 13

### Step 2

- Assemble up to five (5) mast sections on the ground.  
∞SEE **BOLTING MAST SECTIONS AND MAST END SECTION**, ON PAGE 47
- Lift the assembled mast sections with an independent lifting equipment (crane, crane truck or forklift truck) and position the masts opposite those of the lifting unit. The lifting bars must on the right side.
- Install and bolt the mast sections on those of the lifting unit. Keep the assembly secure with the independent lifting system (crane, crane truck or forklift truck).

### Step 3

- Remove the plankings and planking attachments under the location of the mast anchors **before** raising the lifting unit to the height of the next mast anchor.
- Raise the unit up to the location for the second mast anchor.
- Replace the plankings and planking attachments once the previously installed anchor is installed.
- Install the second mast anchor at 20'-0" (6,0 m) from the ground. This height is a recommendation. For more information on the permitted installation heights for the second anchor,  
∞SEE TABLE 1 - DIMENSIONS AND CLEARANCE, ON PAGE 13.

Once the two (2) first anchor devices are installed, you may continue the installation without needing to support the mast with the independent lifting system (crane, crane truck or forklift).

- You may now continue installing the mast sections and subsequent mast anchors. You can pre-assemble up to 40'-0" (12,2 m) [8 mast sections] of mast sections and lift the assembly to bolt it to the mast (See [Figure 48](#)).
- Continue with the installation respecting the method described above.
- If you are using a self-erecting system (**optional - self-erecting system**), go to **Step 4**, (see [Figure 76](#)).
- Raise the platform and complete the installation of the mast sections and anchors up to the desired height. Please observe the maximum distance of 31'-0" (9,5 m) ± 5'-0" (1,5 m) between the subsequent anchors. Also, please observe the maximum installation distance specific to the dimensions of ground base units – **Chapter A** (TABLE 1 - DIMENSIONS AND CLEARANCE, ON PAGE 13).
- Once the last mast section is installed, bolt the mast end section.  
∞SEE [Figure 73 - BOLTING MAST AND MAST END SECTIONS](#), ON PAGE 61
- Finally lower the platform to the ground and install your bridge and extension sections in accordance with the installation instructions defined in **Chapter D**. Complete the platform installation (add fittings, guardrails and other remaining accessories...) and install the protective wire mesh on the lifting unit (See [Figure 81](#)).

**Installing mast sections and anchoring devices / 20K Platform with ground base (continued)**

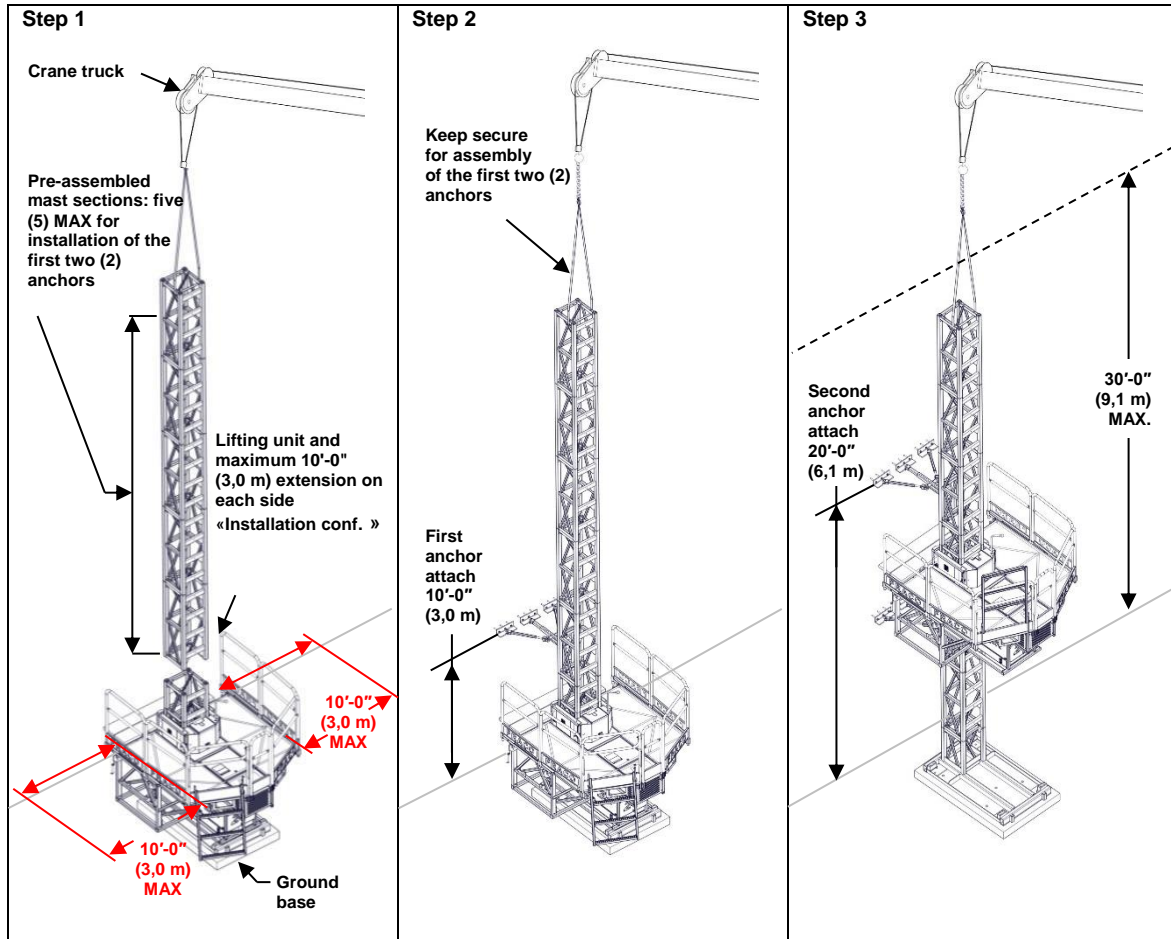


Figure 75 - Installation of masts and anchors, ground base

## Installing mast sections and anchoring devices / 20K Platform with ground base (continued)

### Step 4 (Optional - self-erecting system)

Once the first two (2) anchors have been installed, you may continue the installation using the self-erecting system.

- Lower the unit to the ground and install the self-erecting system. For more details  
∞SEE FIGURE 79 - SELF-ERECTING ASSEMBLY, ON PAGE 80
- Load up to a **MAXIMUM** of eight (8) mast sections on each side of the platform. Attention, it is important to always load the platform from both sides during the installation.
- Raise the platform and complete the installation of the mast sections and anchors up to the desired height. Please observe the maximum distance of 31'-0" (9,5 m) ± 5'-0" (1,5 m) between the subsequent anchors. Also, please observe the maximum installation distance specific to the dimensions of ground base units – **Chapter A** (TABLE 1 - DIMENSIONS AND CLEARANCE ON PAGE 13).
- Once the last mast section is installed, bolt the mast end section.  
∞SEE **Figure 73** - BOLTING MAST AND MAST END SECTIONS, ON PAGE 61
- Then lower the platform to the ground and remove the self-erecting system.
- With the platform still at ground level, install your bridge and extension sections in accordance with the installation instructions in **Chapter D**. Complete the platform installation (add fittings, guardrails and other remaining accessories...) and install the protective mesh on the lifting unit (See **Figure 81**).
- Make sure that all the locks of the self-erecting system are present before using the self-erecting system.

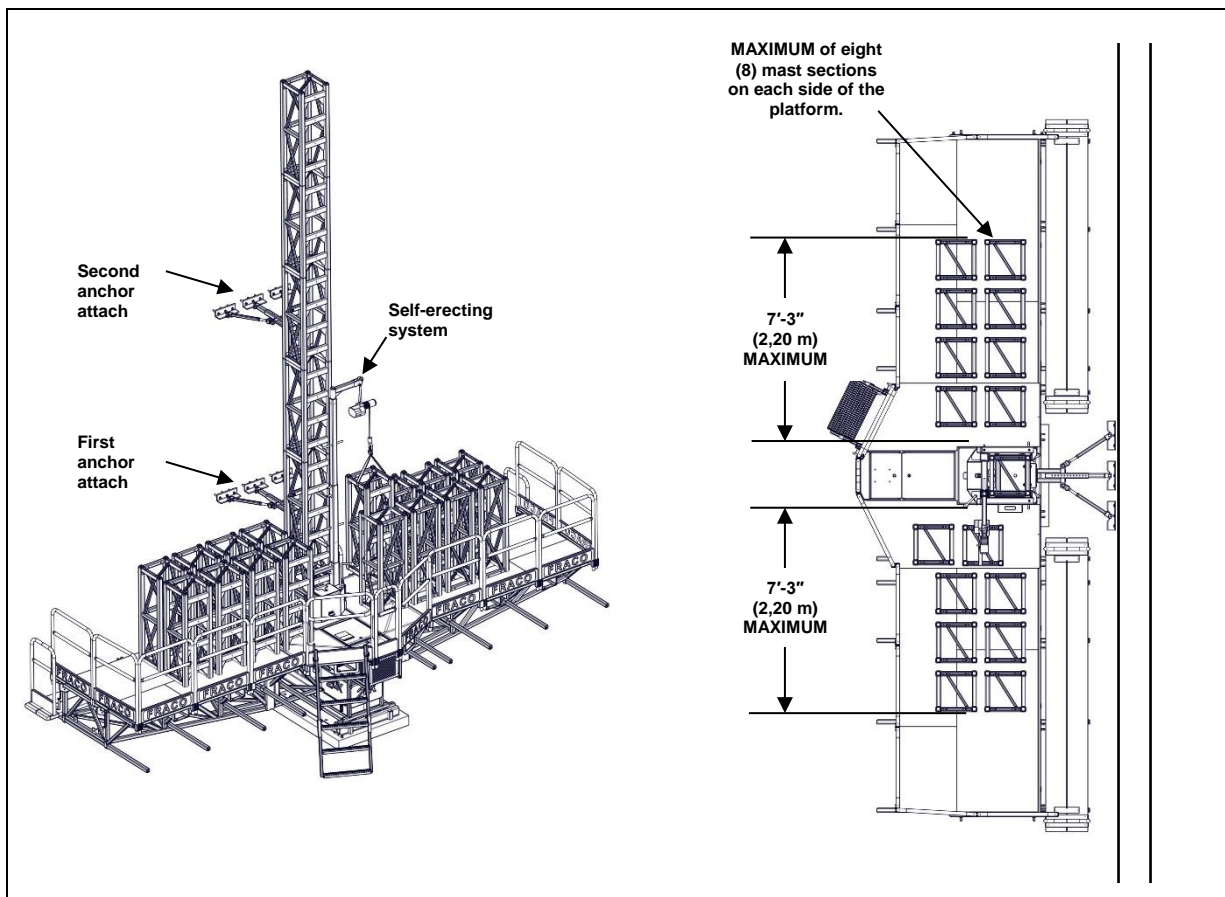


Figure 76 - Installation of masts and anchors on a ground base, self-erecting (optional)



## Installation of mast sections and anchor devices / 20K platform with freestanding base (Universal and 20K)

**IMPORTANT!** In the case of a freestanding installation ONLY (with a working height not exceeding 45'-0" [13.7 m], thus not requiring anchors), you are permitted to install the complete platform in its final working configuration, including extension, bridge, plankings, guardrails and accessories, prior to installation of the mast sections.

### Step 1

- You may install up to a **MAXIMUM** 10'-0" (3,0 m) extension on each side of the unit during installation of the mast sections and mast anchors. Consider this as the « **Setup configuration** ».
- Install the outriggers, planking guardrails, planking attachments, guardrails, guardrail pocket holders and plankings on the lifting unit.
- For installation with a crane truck, you may pre-assemble up to 40'-0" (12,2 m) [8 mast sections] of mast sections on the ground and install them by lifting them up with a lifting sling. Bolt the mast sections together respecting the defined tightening torques.  
∞SEE **BOLTING MAST SECTIONS AND MAST END SECTION ON PAGE 61**
- If you are using a self-erecting system (**optional - self-erecting system**), go to **Step 4**

### Step 2

- Raise the platform under the position of the first mast anchor.
- Place the plankings and planking attachments under the location of the mast anchors to be installed.
- Install the first mast anchor at 30'-0" (9,1 m) from the floor or at a maximum height of 45'-0" (13,7 m) from the ground (in this specific case, consult the dimensions for freestanding base in **Chapter A** (TABLE 1 - DIMENSIONS AND CLEARANCE, ON PAGE 13)).

### Step 3

- You may again pre-assemble up to 40'-0" (12,2 m) [8 mast sections] of mast sections, position them using the crane truck over the previously installed mast and bolt the sections together.
- If you are using a self-erecting system (**optional - self-erecting system**), go to **Step 5**
- Remove the plankings and planking attachments from the space below the mast anchor **before** raising the lifting unit to the height of the next mast anchor.
- Raise the unit up to the location of the second mast anchor to be installed.
- Replace the plankings and planking attachments under the location of the second mast anchor to be installed.
- Then install the second anchor 31'-0" (9,5 m) ± 5'-0" (1,5 m) above the first. This dimension is the maximum allowed between all subsequent anchor devices.
- Complete the installation of the mast sections and anchors to the desired height and bolt the mast end section (see **Figure 73**) above the last mast section.
- Finally lower the platform to the ground and install your bridge and extension sections in accordance with the installation instructions defined in **Chapter D**. Complete the platform installation (add fittings, guardrails and other remaining accessories...) and install the protective mesh on the lifting unit (See **Figure 81**).

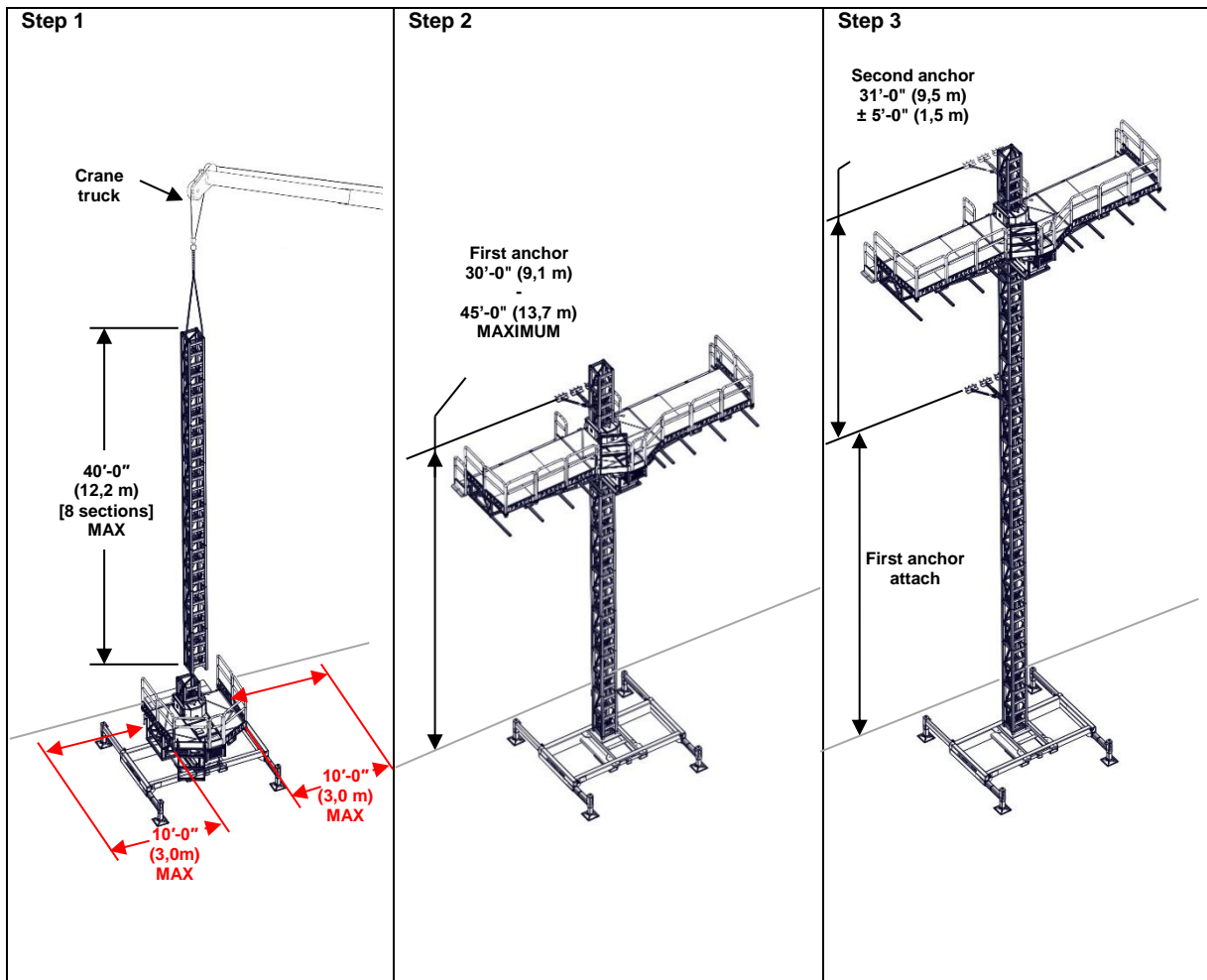


Figure 77 - Installation of masts and anchors, freestanding base

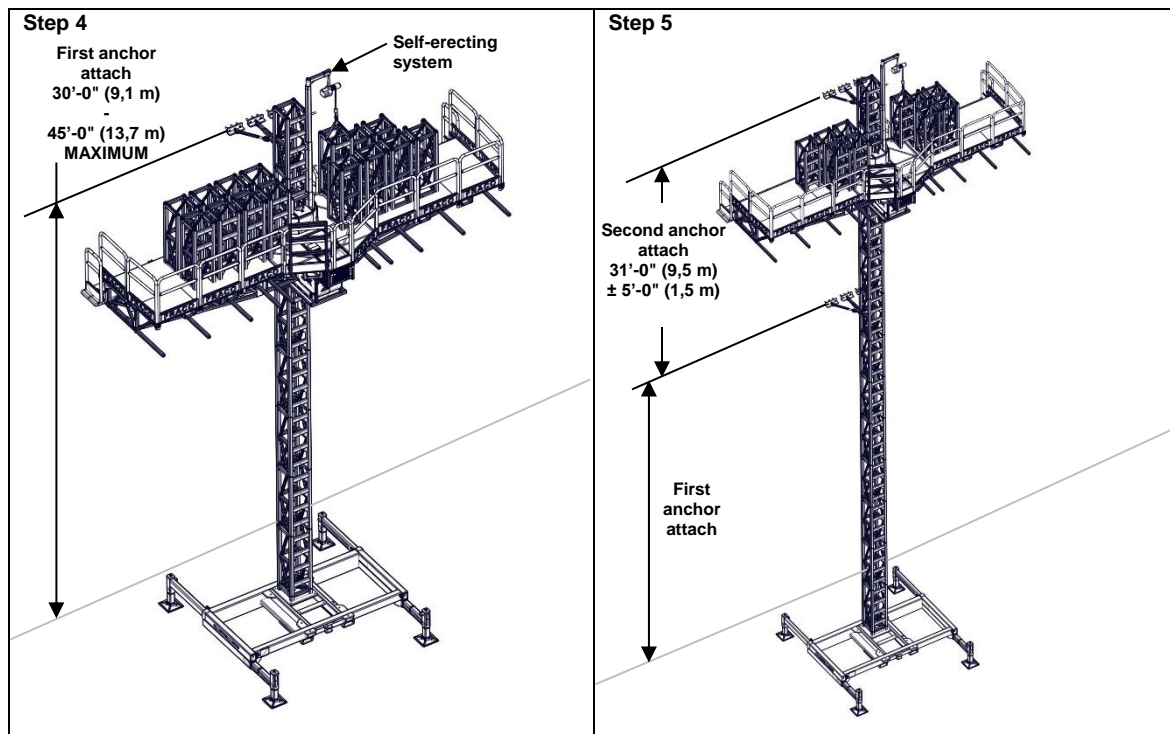
**Step 4 (Optional - self-erecting system)**

If you use a freestanding base, you can use the self-erecting system as soon as you start installing the mast sections and mast anchors devices.

- Lower the unit to floor level.
- You may install up to a **MAXIMUM** 10'-0" (3,0 m) extension on each side of the unit during installation of the mast sections and mast anchors. Consider this as the « **Setup configuration** ».
- Install the outriggers, planking guardrails, planking attachments, guardrails, guardrail pocket holders and plankings on the lifting unit.
- Then install the self-erecting system and load up to eight (8) mast sections on each side of the platform [sixteen (16) sections per platform]. Attention, it is important to always equally load the platform on both sides as shown in ([Figure 76](#)).
- Raise the unit under the location of the first mast anchor.
- Replace the plankings and planking attachments under the location of the first mast anchor.
- Install the first mast anchor at 30'-0" (9,1 m) from the floor or at a maximum height of 45'-0" (13,7 m) from the floor (in this specific case, consult the dimensions for freestanding base in **Chapter A** (TABLE 1 - DIMENSIONS AND CLEARANCE, ON PAGE 13).

**Step 5 (Optional - self-erecting system)**

- Load up to a **MAXIMUM** of eight (8) mast sections on each side of the platform. Attention, it is important to also load the platform on both sides.
- Remove plankings and planking attachments under the anchors and lift the platform under the location of the second anchor.
- Replace the plankings and planking attachments under the location of the second mast anchor
- Then install the second anchor 31'-0" (9,5 m)  $\pm$  5'-0" (1,5 m) above the first. This dimension is the maximum allowed between all subsequent anchor devices.
- Proceed as such for the installation of all necessary mast sections and anchor devices until the desired height is reached.
- Once the last mast section is installed, bolt the mast end section.  
∞SEE [Figure 73](#) - BOLTING MAST AND MAST END SECTIONS, ON PAGE 61
- Lower the platform to floor level and remove the self-erecting system.
- With the platform at ground level, install your bridge and extension sections in accordance with the installation instructions in **Chapter D**. Complete the platform installation (add fittings, guardrails and other remaining accessories...) and install the protective mesh on the lifting unit (see [Figure 81](#)).



**Figure 78 - Installation of masts and anchors on a freestanding base, self-erecting (optional)**



## Installation of the self-erecting system (optional)

**IMPORTANT!** Always use a safety harness that is properly secured to a regulatory attachment point on the platform when assembling and dismantling the self-erecting system.

∞SEE REGULATORY ATTACHMENT POINTS SECTION, ON PAGE 9

**IMPORTANT!** Ensure that all locks of the self-erecting system, such as items 5 and 9, are present before using the self-erecting system.

### Step 1

- Position and bolt the « U » fastener for the self-erecting system (20491578) on the lifting unit. Use the bolts (BOA-2031) provided with the protective mesh.

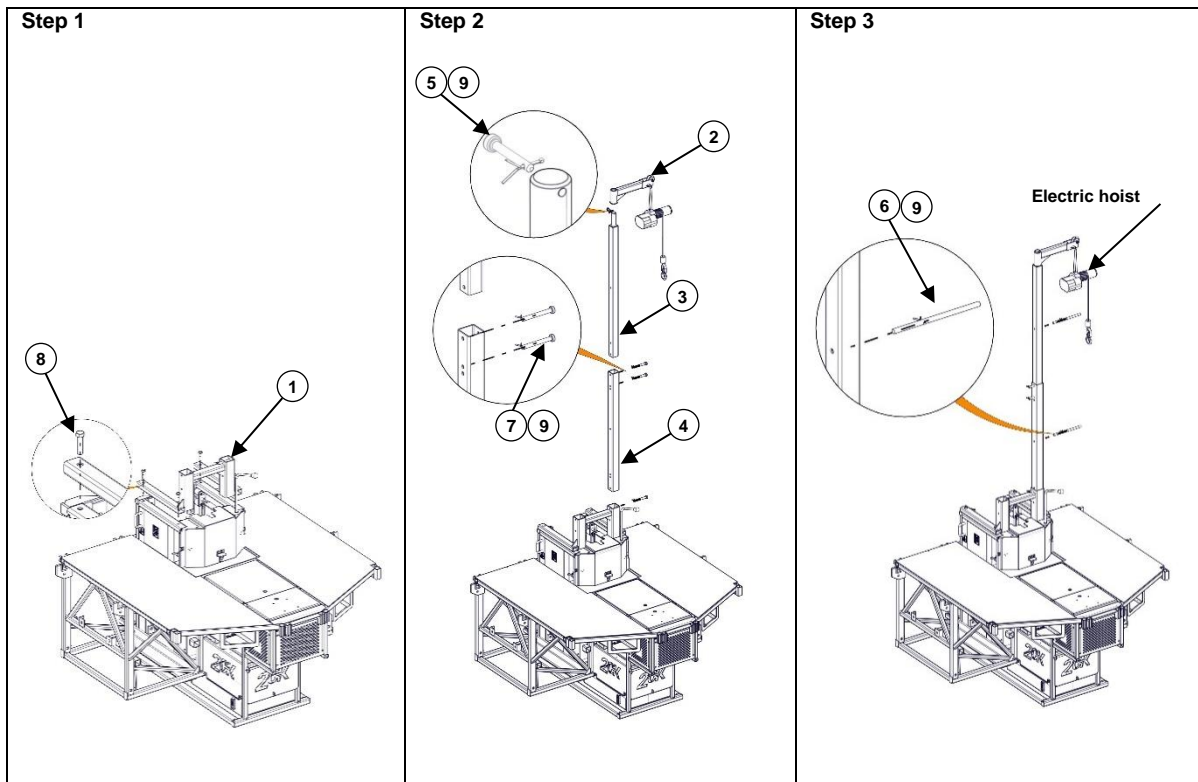
### Step 2

- Position the tubes and the boom on the self-erecting system and lock them in place with the specified locking shafts.

∞SEE FIGURE 79 - SELF-ERECTING ASSEMBLY, ON PAGE 80

### Step 3

- Install the washer shafts as ladder rungs. Use the ladder rungs to lift and install the electric hoist. Once the electric hoist has been installed, remove the washer shafts and store them for later use when disassembling.



No	Item	Description	No	Item	Description
01	20491578	FRSM-20K self-erecting U tie	06	25490077	Pin with washer (dia. 5/8" x 14")
02	20490162	Self-erecting boom (3" x 3" x 21-1/4")	07	25490112	Pin (dia. 5/8" x 6-9/16")
03	20490331	Self erecting tube with shaft (3" x 3" x 5'-10")	08	BOA-2031	Bolt 3/4"-10unc x 3" A325 galv.
04	20490342	Self erecting tube (3-1/2" x 3-1/2" x 4' 10")	09	GOU-1120	Split Pin 1/8" x 2" zinc
05	25490011	Pin (dia. 3/8" x 3-1/8")			

Figure 79 - Self-erecting assembly

### Mast levelling with anchor devices

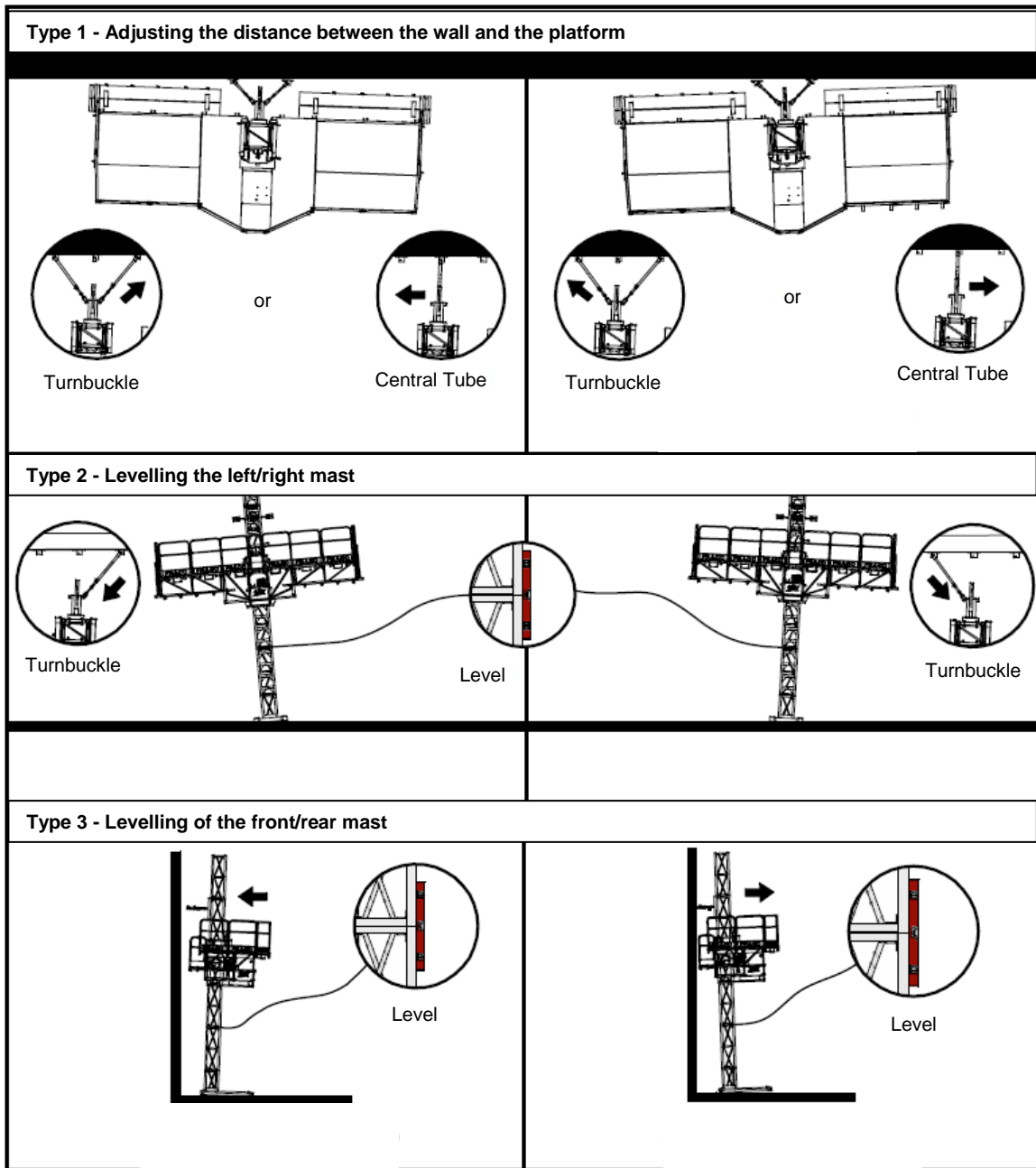


Figure 80 - Levelling with anchor devices

## Installation of the protection screen

The protective wire mesh is installed in the same location as the self-erecting system using the same bolts.

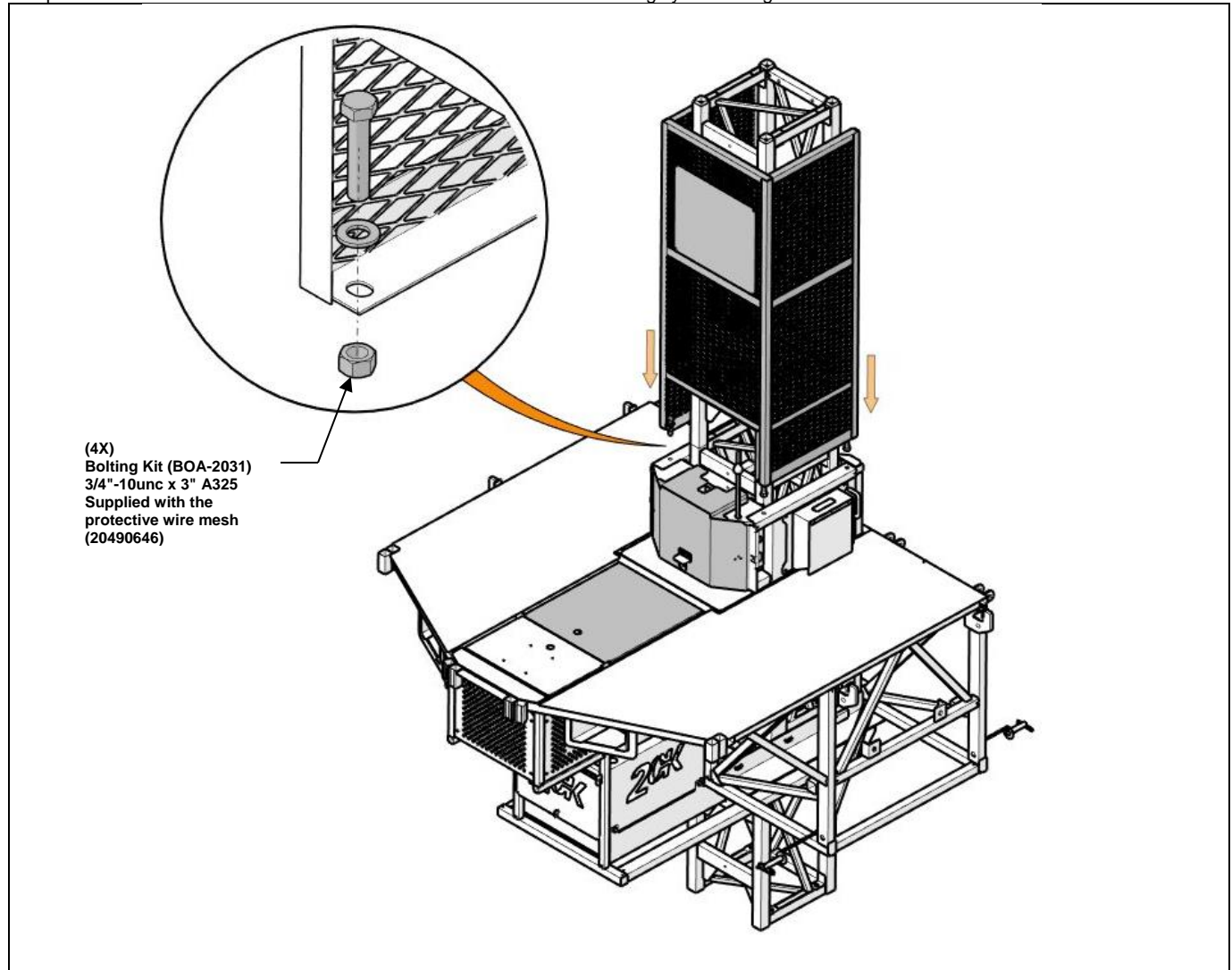


Figure 81 - protective wire mesh

## Disassembly of masts and anchors with ground base

### Step 1

- Lower the unit to the floor and unload all equipment, debris and materials from the platform.
- Remove the protective wire mesh (see [Figure 81](#)).
- Disassemble any extension section that does not comply with a **MAXIMUM** 10'-0" (3,0 m) extension on each side of the unit when disassembly of the mast sections and mast anchor devices. Consider this as the « **Installation configuration** ».
- If you have and use a self-erecting system (**optional – self-erecting system**), install it using the bolts provided in the protective wire mesh kit and go to **Step 3** once **Step 1** is completed.
- Raise the platform until reaching the top of the mast and unbolt the mast end section.
- Sling the top of the mast with an independent lifting system (crane truck, sling, belt, etc.) to dismantle several mast sections at a time. This is not necessary if you are using the self-erecting system.
- Then descend until you find the location of the highest anchor (last anchor device).

### Step 2

- Place the plankings and planking attachments under the anchors to be removed.
- Loosen the turnbuckles and remove the anchor devices. Perform repairs to the wall if necessary.
- Remove the plankings and planking attachments under the anchor points.
- Then lower the platform to the next anchor.
- Unbolt and remove the mast sections using an independent lifting equipment (crane, crane truck or forklift truck) following the same instructions as for the installation (see [Figure 75](#)). Dismantle up to a **MAXIMUM** 40'-0" (12,2 m) [eight (8) mast sections] at a time for all anchors located above the first two (2) ones.
- Remove the plankings, planking attachments and planking guardrails and planking attachments at the anchor dedicated locations.
- Continue dismantling until only the first two (2) anchor devices remain.

### Step 3 (Optional - self-erecting system)

- Place the plankings and planking attachments under the anchors to be removed.
- Loosen the turnbuckles and remove the anchor devices. Perform repairs to the wall if necessary.
- Remove the plankings, planking supports and planking railings at the anchor dedicated location between each movement of the platform.
- Unbolt and remove the mast sections using the self-erecting system following the same instructions as for the installation (see [Figure 76](#)). Load equally on each side of the platform up to **MAXIMUM** eight (8) mast sections at a time (sixteen [16] sections per platform **MAXIMUM**).
- Continue disassembling until only the first two (2) anchor devices remain.
- Lower the platform to the floor and remove the self-erecting system.

### Step 4

**Important!** It is mandatory to support the mast using an independent lifting system (crane truck, sling, belt, etc.) during the dismantling of the first two (2) mast anchors.

- Bring the platform underneath the second anchor device and install the plankings, planking supports and guardrails intended for the location under the anchors.
- Remove the second anchor device and perform any necessary repairs to the wall.
- Install the plankings, planking attachments and guardrails intended for under the anchors.
- Lower the unit under the first anchor device.
- Install the plankings, planking attachments and guardrails intended for under the anchors.
- Remove the first anchor device and perform any necessary repairs to the wall.
- Lower the unit to the ground and unbolt the five (5) highest mast sections suspended by a crane truck.
- Remove the five (5) mast sections and place them on the ground to dismantle them.
- Complete dismantling the unit on the base.

**Disassembly of masts and anchors with ground base (CONTINUED)**

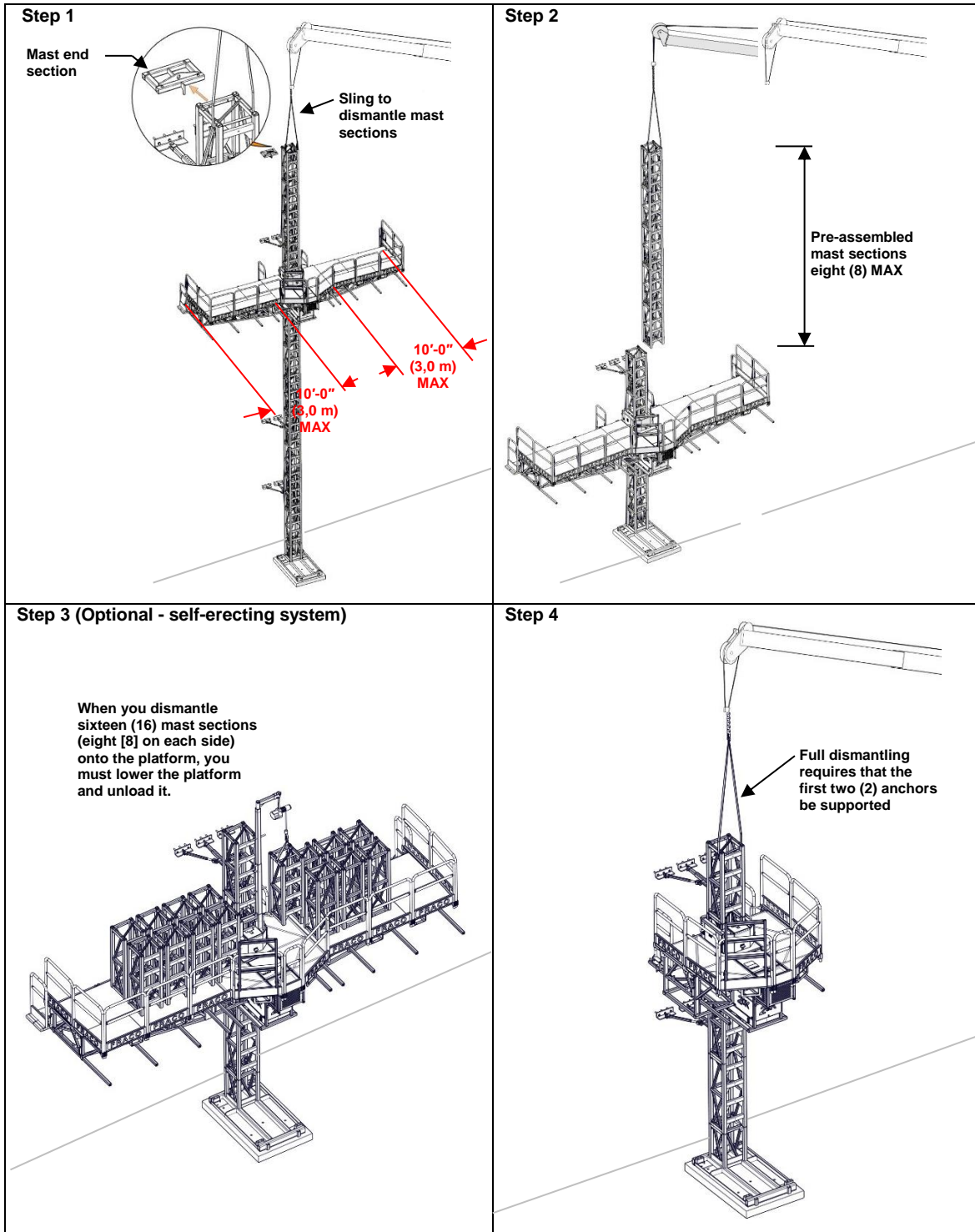


Figure 82 - Dismantling masts and anchors and ground base

## Disassembly of anchors with freestanding base (universal, 20K)

### Step 1

- Lower the unit to the floor and unload all equipment, debris and materials from the platform.
- Remove the protective wire mesh (see [Figure 81](#)).
- Disassemble any extension section that does not comply with a **MAXIMUM** 10'-0" (3,0 m) extension on each side of the unit during the disassembly of the mast sections and mast anchor devices. Consider this as the « **Installation configuration** ».
- If you have a self-erecting system (optional), install it using the bolts provided in the protective wire mesh kit and go to **Step 3** once **Step 1** is completed.
- Raise the platform until reaching the top of the mast and unbolt the mast end section.
- Sling the top of the mast with an independent lifting system (crane truck, sling, belt, etc.) to dismantle several mast sections at a time. This is not necessary if you are using the self-erecting system.
- Then lower until you find the location of the highest anchor (last anchor device).

### Step 2

- Place the plankings and planking attachments under the anchors to be removed.
- Loosen the turnbuckles and remove the anchor devices. Perform repairs to the wall if necessary.
- Remove the plankings, planking attachments and railings at the anchor dedicated locations.
- Then lower the platform to the next anchor.
- Unbolt and remove the mast sections using an independent lifting equipment (crane, crane truck or forklift truck) following the same instructions as for the installation (see [Figure 75](#)). Dismantle up to **MAXIMUM** 40'-0" (12,2 m) [8 mast sections] mast sections at a time for all anchors located above the first two (2) mast sections.
- Install the plankings, planking supports and railings at the anchor dedicated locations.
- Continue disassembling until only the first two (2) anchor devices remain.

### Step 3 (Optional - self-erecting system)

- Place the plankings and planking attachments under the anchors to be removed.
- Loosen the turnbuckles and remove the anchor devices. Perform repairs to the wall if necessary.
- Remove the plankings, planking supports and planking railings at the anchor dedicated location between each movement of the platform.
- Unbolt and remove the mast sections using the self-erecting system following the same instructions as for the installation (see [Figure 76](#)). Load equally on each side of the platform up to **MAXIMUM** eight (8) mast sections at a time (sixteen [16] sections per platform **MAXIMUM**).
- Continue disassembling until only the first two (2) anchor devices remain.
- Lower the platform to the floor and remove the self-erecting system.

### Step 4

On a freestanding base, it is not necessary to sling the mast when disassembling the first two (2) anchors.

- Lower the platform underneath the second anchor device and install the plankings, planking supports and railings intended for the location under the anchors.
- Remove the second anchor device and perform any necessary repairs to the wall.
- Remove the plankings, planking attachments and railings intended for under the anchors.
- Lower the unit under the first anchor device.
- Install the plankings, planking attachments and railings intended for under the anchors.
- Remove the first anchor device and perform any necessary repairs to the wall.
- Lower the unit to the floor level and unbolt all mast sections suspended by a crane truck, except the first two (2).
- Remove the mast sections suspended by a crane truck and place them on the ground for disassembly.
- Complete the disassembly of the unit on the base.

**!** Disassembly of anchors with freestanding base (universal, 20K) (CONTINUED)

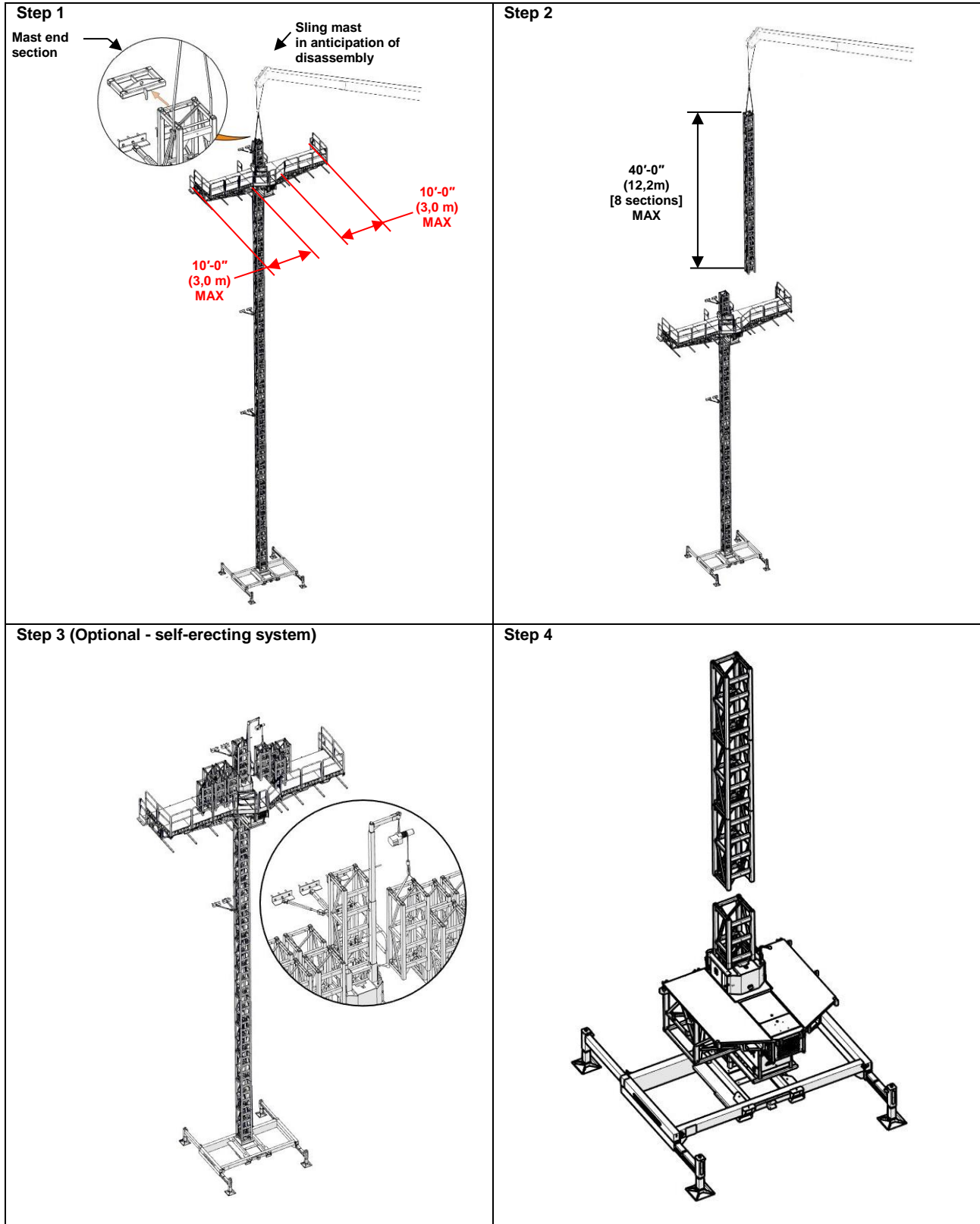


Figure 83 – Disassembly of masts and anchors, freestanding base (universal, 20K)

## Chapter D - Accessories

### Bridge and extension accessory

#### Installation of guardrail pocket holders and guardrails

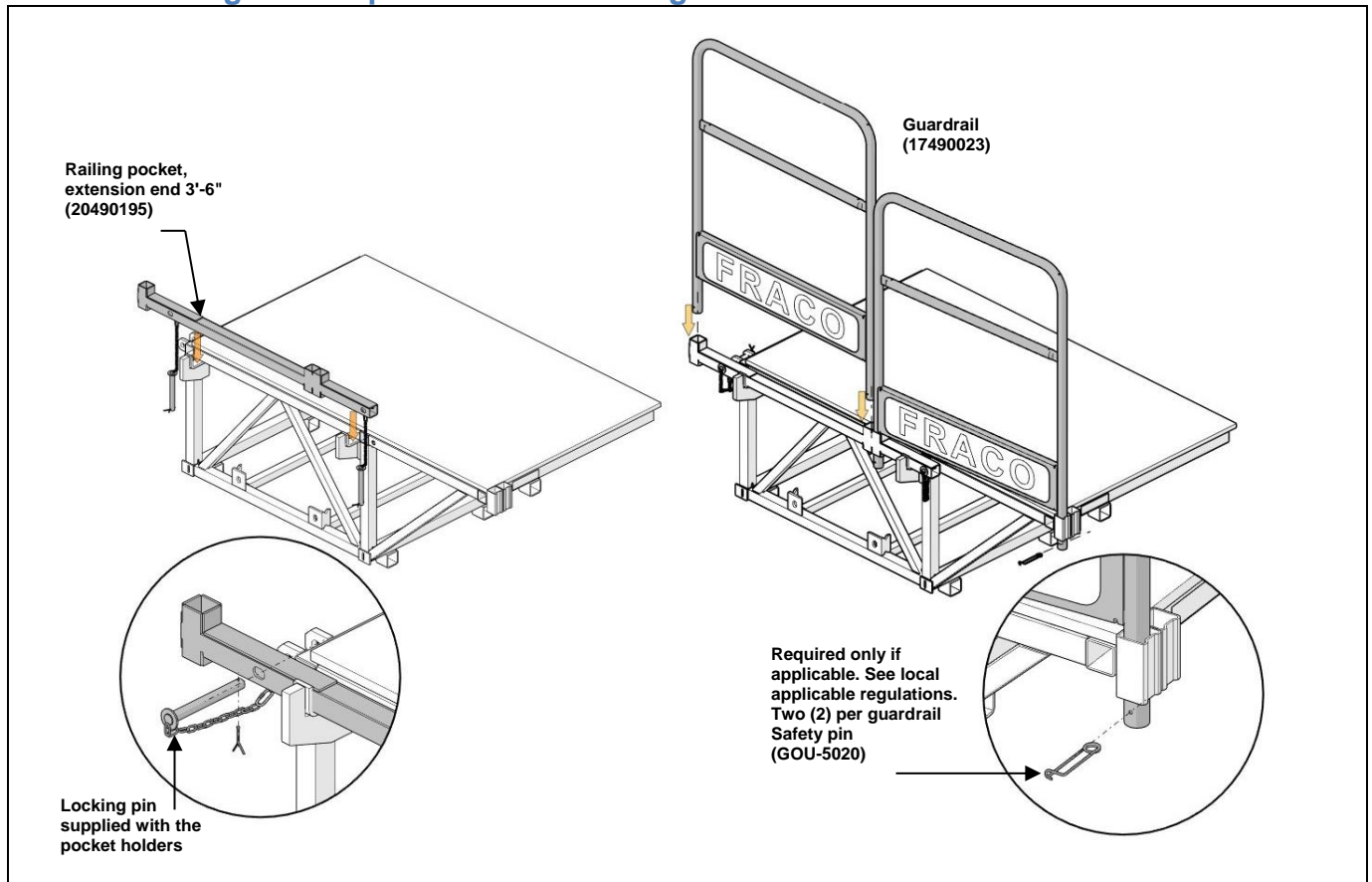


Figure 84 - Installing guardrails



## Installing the outriggers

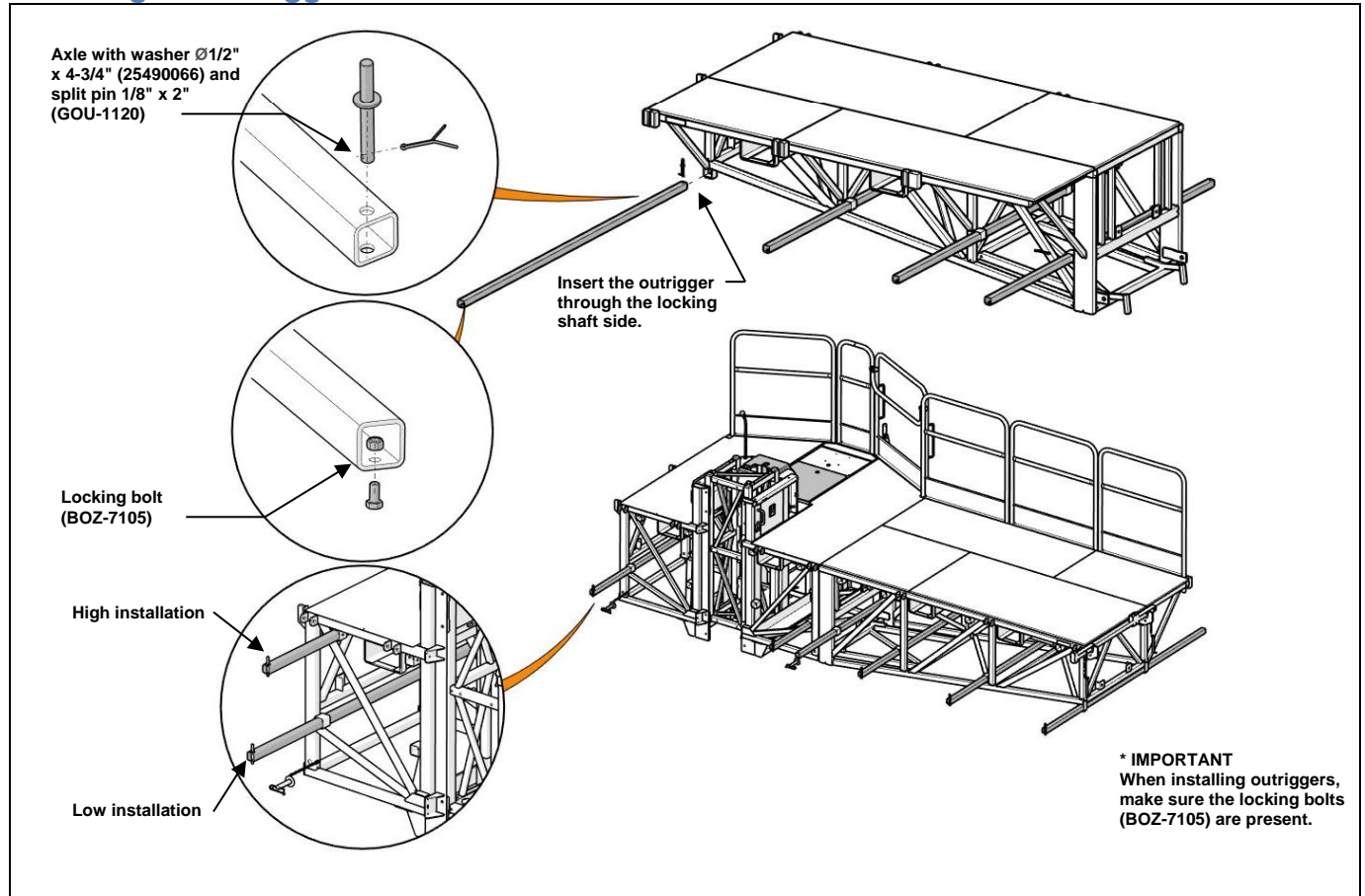


Figure 85 - Installing outriggers

## Configuration of the outriggers

The configurations presented below with reinforced outriggers must be approved by FRACO and its Engineering Department. In addition, the plankings must never extend beyond the last outrigger by more than 12"(300 mm) laterally.

SEE [Figure 91](#), ON PAGE 93.

### Outriggers

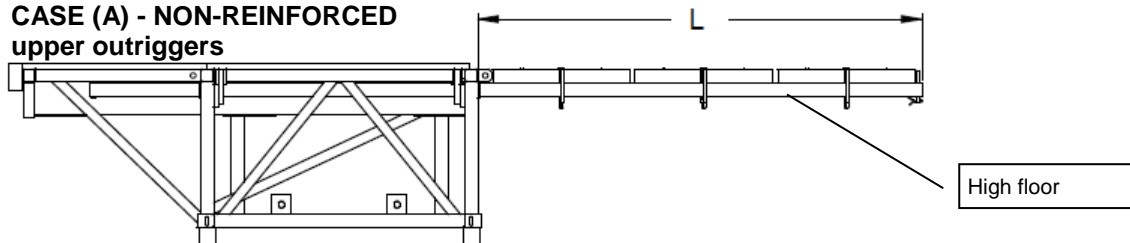
- A minimum of three (3) outriggers must be used to install plankings beyond (L) = 5'-4" (1,62 m).
- The outriggers may be installed at the top or bottom of the platform as needed.
- Reinforced outriggers may only be installed at the top level.
- The reinforced outrigger tie (20490544) must be installed from 6" (152 mm) to 36" (914 mm) from the end of the outrigger.
- The maximum length (L) at which the outrigger may be extended is given in the following table. This dimension is calculated by taking into account 2" x 10" (50 mm x 254 mm) plankings. For any installation requiring a length (L) greater than 6'-0" (1,8 m), reinforced outriggers **must** be used.

Code	Outrigger type	Max length (L)
19010034	Outrigger 3/16" x 2" x 2" x 8'-8" (4,65 mm x 50 mm x 50 mm x 2,65 m) <b>(Standard 8'-8" [2,65 m])</b>	5'-4" (1,6 m)
19010045	Outrigger 3/16" x 2" x 2" x 10'-6" (4,65 mm x 50 mm x 50 mm x 3,20 m) <b>(Standard 10'-6" [3,20 m])</b> (Requires a minimum of 3 side-by-side outriggers)	6'-0" (1,8 m)
*19010045	Outrigger 3/16" x 2" x 2" x 10'-6" (4,65 mm x 50 mm x 50 mm x 3,20 m) <b>(Reinforced outrigger 10'-6" [3,20 m])</b>	7'-0" (2,1 m) REINFORCED
*19010056	Outrigger 3/16" x 2" x 2" x 13'-6" (4,65 mm x 50 mm x 50 mm x 4,10 m) <b>(Reinforced outrigger 13'-6" [4,10 m])</b>	8'-0" (2,4 m) REINFORCED
20492063	Central tube 2" x 2" x 6'-0" (50 mm x 50 mm x 1,82 m) (Outrigger reinforcement 8'-8" [2,65 m] and 10'-6" [3,20 m])	N/A

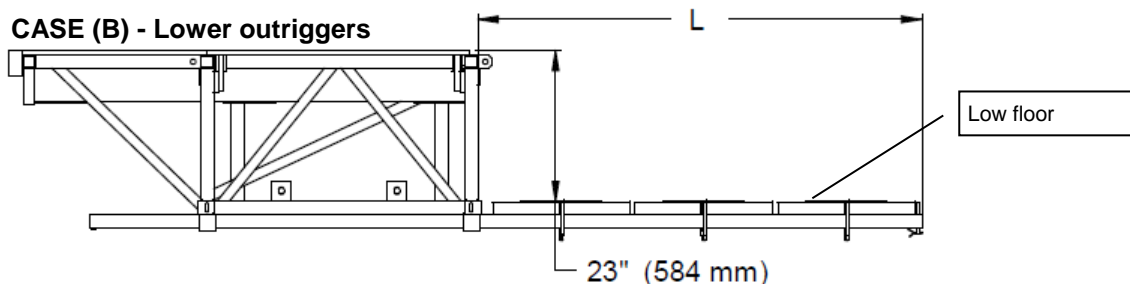
\* For any installation requiring outrigger with (L) greater than 6'-0" (1,82 m), consult the FRACO engineering department.

### Standard outrigger:

#### CASE (A) - NON-REINFORCED upper outriggers



#### CASE (B) - Lower outriggers



### Reinforced outrigger:

#### CASE (C) - REINFORCED upper outriggers

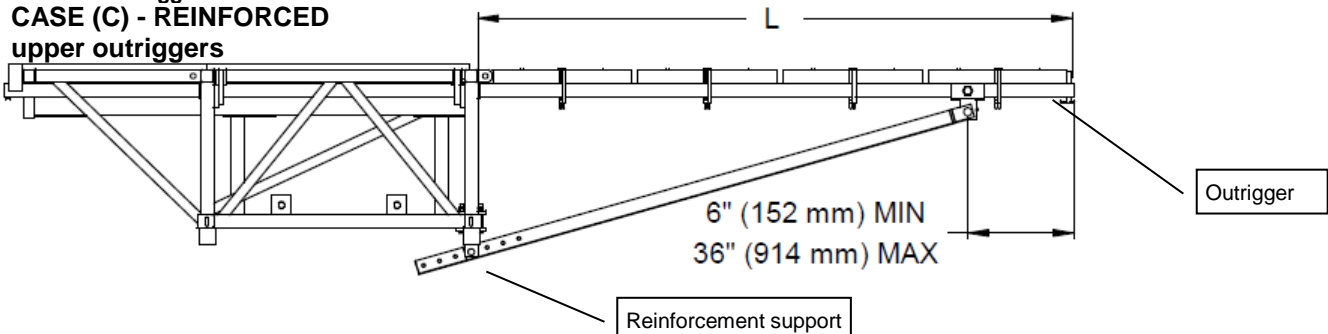


Figure 86 - Outrigger extension

- To be extended to their maximum capacity, the outrigger shall be spaced not more than 40" (1,0 m) apart.
- **Important!** Use planking approved by the local current regulations.
- The planking configuration presented below is for illustrative purposes only. Layout of the planking must comply with local current regulations.

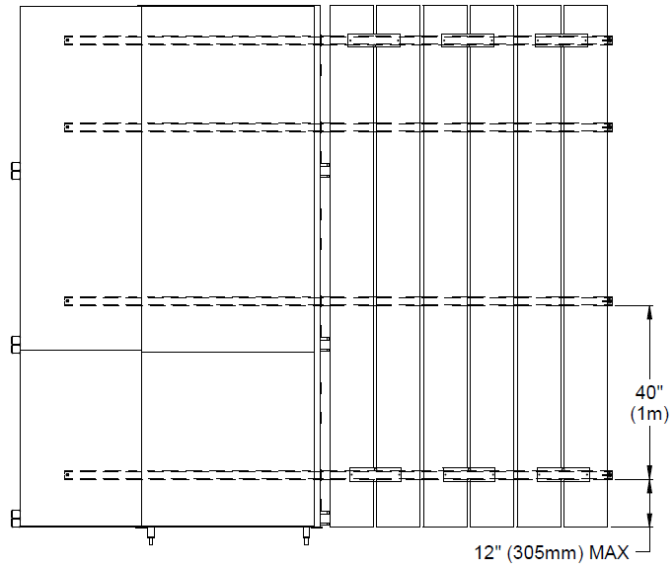
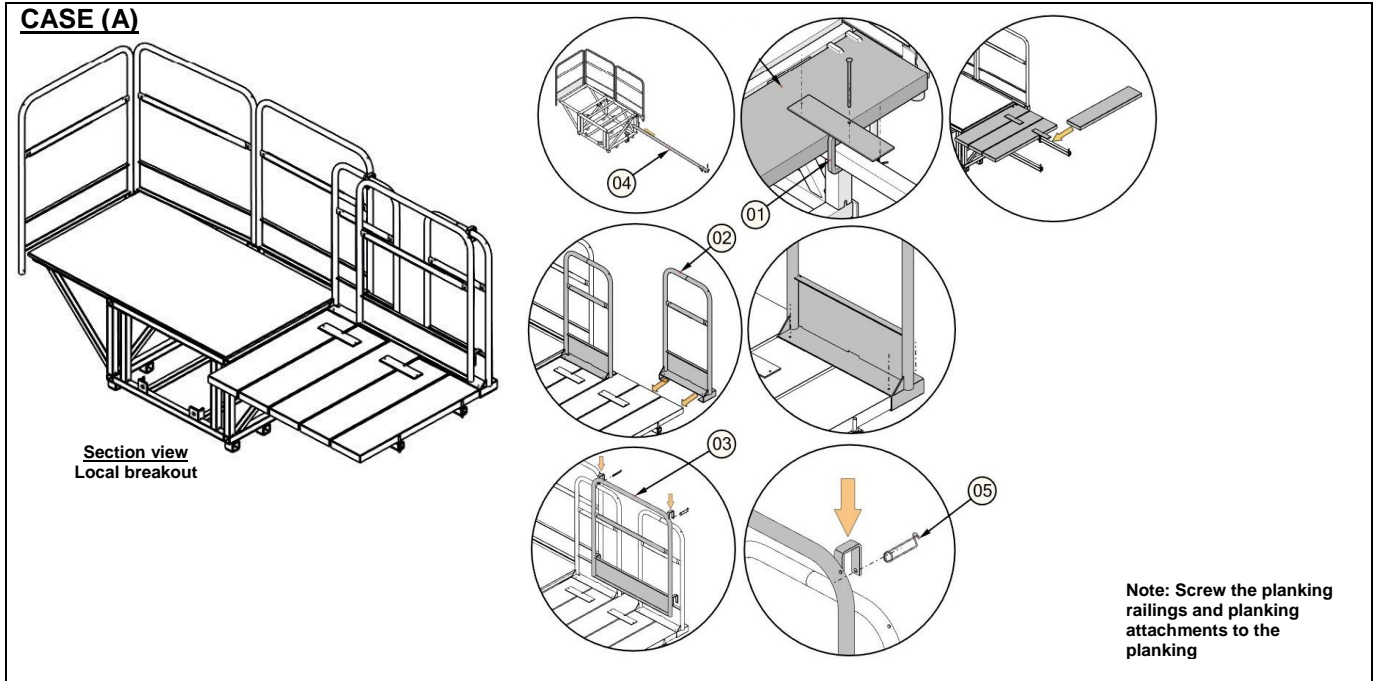
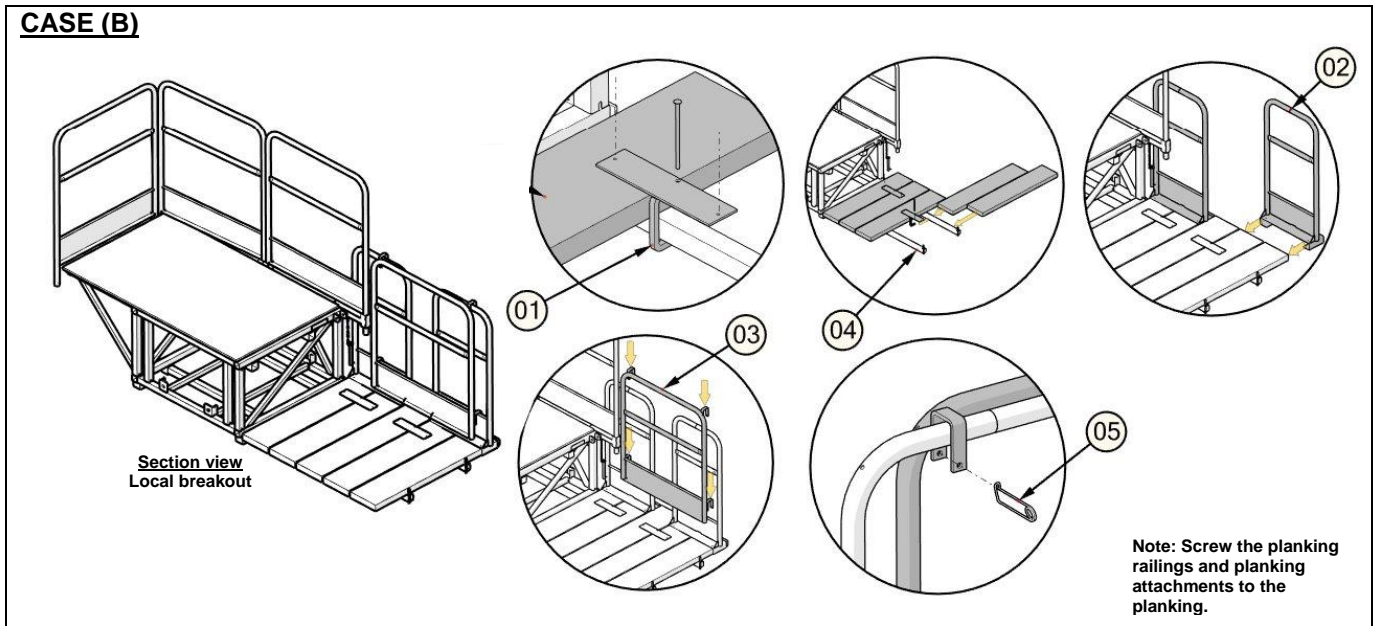


Figure 87 - Spacing between outriggers



No	Item	Description	No	Item	Description
01	20490050	Plank tie (3" x 12")	04	19010034	Outrigger (3/16" x 2" x 2" x 8'-8")
02	17490045	Plank-end guard-rail (21" x 3'-6")	05	GOU-5020	Safety pin 1/8" x 4-1/4"
03	17490034	Extensible guard-rail (3'-4" x 3'-7")			

Figure 88 - Installation of NON-REINFORCED upper outriggers



No	Item	Description	No	Item	Description
01	20490050	Plank tie 3" x 12"	04	19010034	Outrigger (3/16" x 2" x 2" x 8'-8")
02	17490045	Plank-end guard-rail (21" x 3'-6")	05	GOU-5020	Safety pin 1/8" x 4-1/4"
03	17490034	Extensible guard-rail (3'-4" x 3'-7")			

Figure 89 - Installation of lower outriggers

**CASE (C)**

**Section view  
Local breakout**

**Central tube red side down**

**Compatibility table (outriggers - central tube)**

Outrigger	Description	Compatible central tube	Description
19010034	Outrigger 3/16" x 2" x 2" x 8'-8" (4,65 mm x 50 mm x 50 mm x 2,65 m)	22010061	Central tube 2" x 2" x 5'-0" (50 mm x 50 mm x 1,52 m)
19010045	Outrigger 3/16" x 2" x 2" x 10'-6" outrigger (4,65 mm x 50 mm x 50 mm x 3,20 m)	20492063	Central tube 2" x 2" x 6'-0" (50 mm x 50 mm x 1,83 m)
19010056	Outrigger 3/16" x 2" x 2" x 13'-6" (4,65 mm x 50 mm x 50 mm x 4,10 m)	20492063	Central tube 2" x 2" x 6'-0" (50 mm x 50 mm x 1,83 m)

**Note: Screw the planking railings and planking attachments to the planking**

No	Item	Description	No	Item	Description
01	20490050	Plank tie 3" x 12"	07	GOU-1120	Split pin 1/8" x 2" zinc
02	17490045	Plank-end guardrail 21" x 3'-6"	08	20490555	Special outrigger swivel
03	17490034	Extensible guardrail 3'-4" x 3'-7"	09	20490544	Special outrigger tie
04	19010034 19010045 19010056	Outrigger 3/16" x 2" x 2" x 8'-8" Outrigger 3/16" x 2" x 2" x 10'-6" Outrigger 3/16" x 2" x 2" x 13'-6"	10	25490066	Pin with washer dia. 1/2" x 4-3/4"
05	GOU-5020	Safety pin 1/8" x 4-1/4"	11	22010061 22010184	Central tube 2" x 2" x 5'-0" Central tube 2" x 2" x 10'-0"
06	25490033	Locking pin dia. 5/8" x 3-3/16"	12	20490072	Outrigger lock 1" x 2" x 2"

Figure 90 - Installation of REINFORCED upper outriggers

## Detail of plankings and end of plank guardrail

### Plankings

The type, dimensions and arrangement of plankings used on the outriggers shall be in accordance with local standards and regulations.

For information purposes, the plankings used should have the following characteristics:

2" x 10" or 2" x 12" (0,05 m x 0,25 m or 0,05 m x 0,30 m) capable of supporting a load of at least 265 lb (120 kg) over a minimum length of 4'-0" (1,2 m).

Other types of cover may be used, provided that the dimensions of the attachments accessories are in compliance with local standards and regulations.

∞SEE PERMITTED CONFIGURATIONS AND LOAD DISTRIBUTION, ON PAGE 18

∞SEE TABLE 18 - LOAD DEDUCTIONS, ON PAGE 158

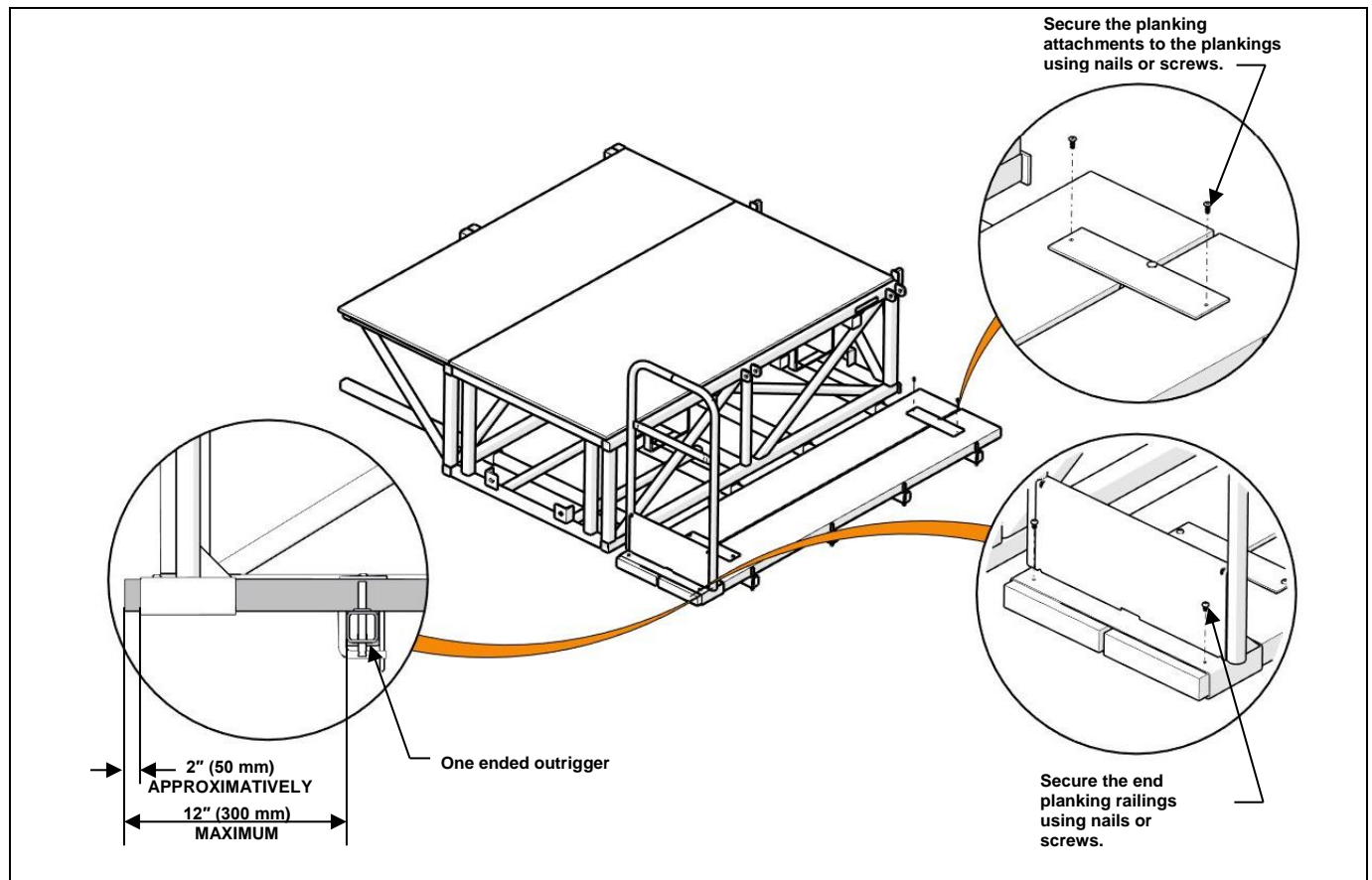


Figure 91 - Detail of planking installation

### Installation of outrigger supports for inside corner return (optional)

**When using outrigger supports, platform expansion must be taken into account and its influence on the permissible configurations and associated load distributions.**  
 ∞ SEE, PERMITTED CONFIGURATIONS AND LOAD DISTRIBUTION, ON PAGE 18.

**If the lateral extension of the extensions on one side of the platform modifies the configuration result (full load, half load, prohibited), the most restrictive result shall always be taken into account.**

**Example: 20K platform with 20'-0" (6,10 m) on each side. If the platform is extended on one side with plankings, the platform changes from Full load → to → half load on one side. The most restrictive of the two states is thus taken into account, namely half-load on this side.**

**Example: 20K platform with 20'-0" (6,10 m) on one side and 23'-4" (7.11 m) on the other side. If the platform is extended on the 20'-0" (6.10 m) side, the platform changes from half-load → to → full load. The most restrictive of the two states is thus taken into account, namely half-load on this side.**

**EXTENSION SECTION**

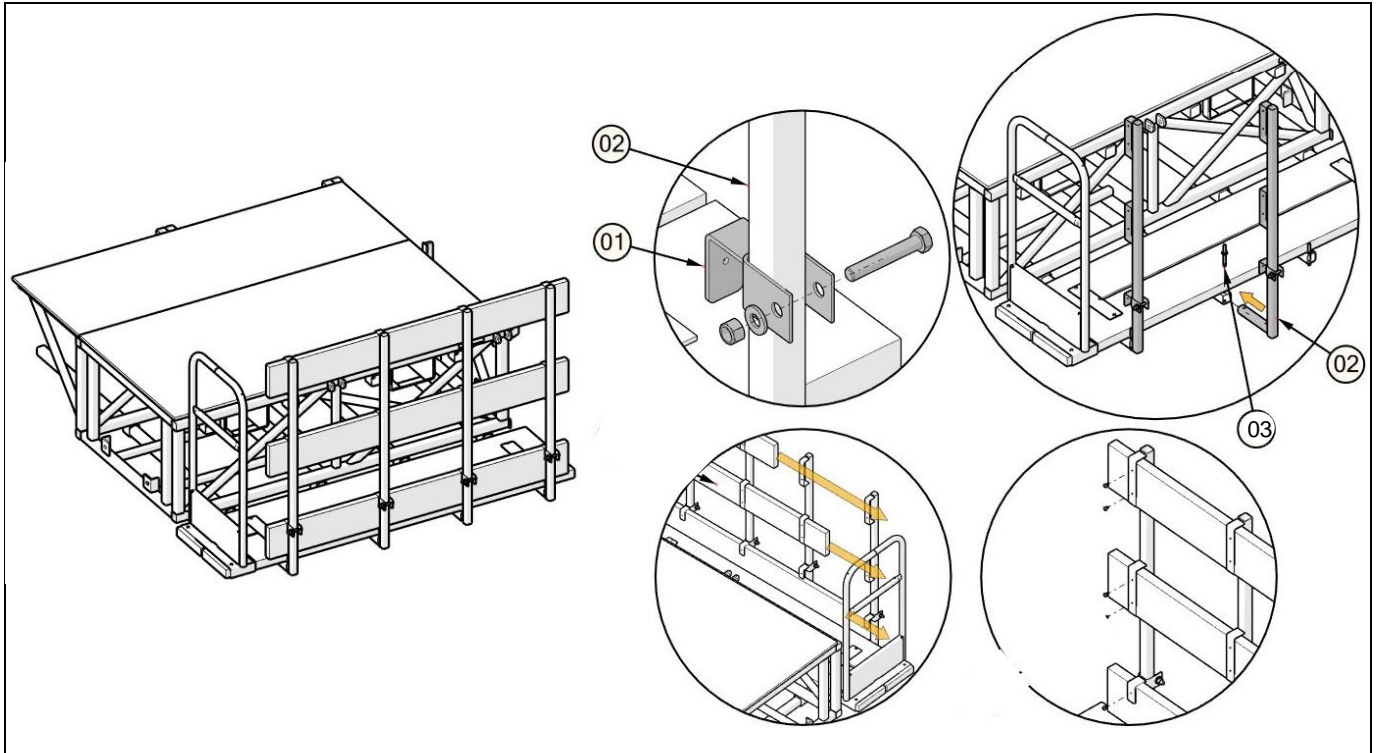
Installation allowed  
 A-B Installation allowed with a 50% load reduction on the indicated side  
 X Installation prohibited

Side B (no extension section)	Side A (no extension section)									
	1	2	3	4	5	6	7	8	9	10
(no extension section)										
									X	X
									A	A
									X	X
									A	A
									X	X
									A	A
									X	X
									A	A
									X	X
									A	A
									X	X
									A	A
									X	X
									A	A
									X	X
									A	A
									X	X
									A	A
									X	X
									A	A

No	Item	Description	No	Item	Description
01	20490038	Outrigger tie	05	190XXXXX	Plank-end additional outrigger
02	25490055	Pin dia. 3/4" x 4-3/16"	06	20490050	Plank tie 3" x 12"
03	GOU-1120	Split pin 1/8" x 2" zinc	07	17490045	Plank-end guard-rail 21" x 3'-6"
04	25490066	Pin with washer dia. 1/2" x 4-3/4"			

Figure 92 - Outrigger support

## Installation of end outrigger guardrail



No	Item	Description	No	Item	Description
01	20491646	« L » guardrail sliding tie	03	25490066	Pin with washer dia. 1/2" x 4-3/4"
02	17490067	« L » outrigger guard-rail 4'-3"			

Figure 93 - Installation of outrigger-end guardrail



### Installation of access guardrails to mast anchor devices

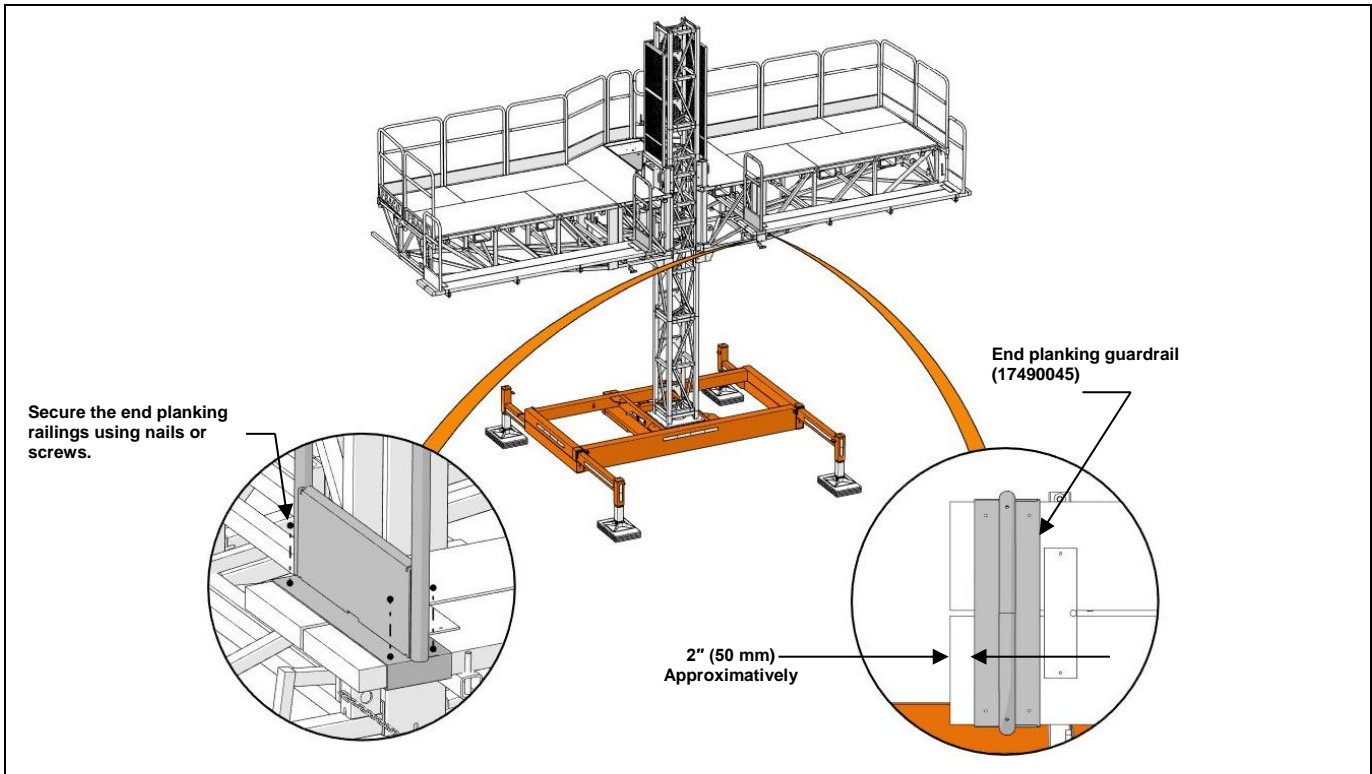
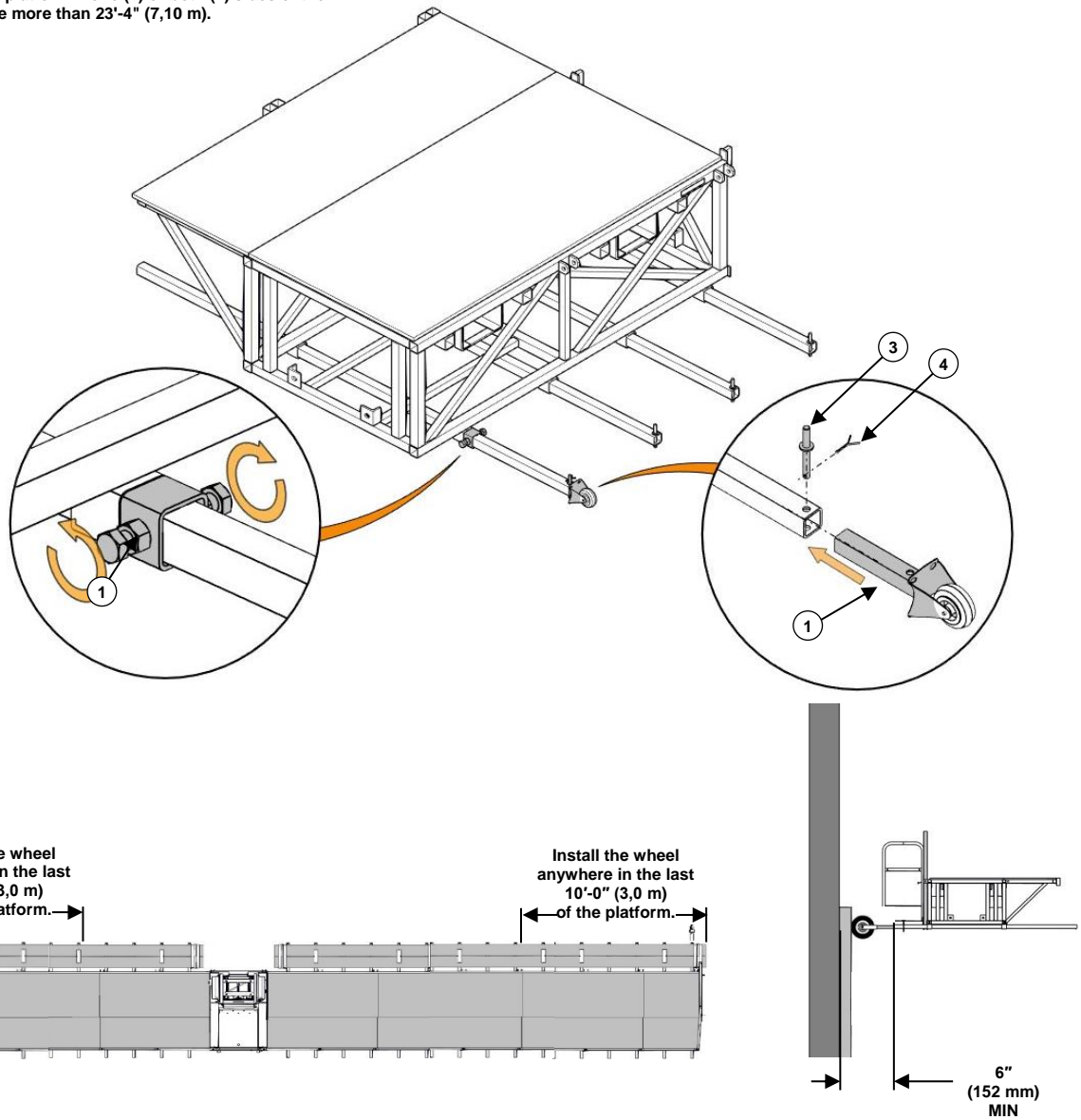


Figure 94 - Installing mast anchor guardrails

## Installing anti-pivot device, small wheel (optional)

**Important!** The anti-pivot system wheels must be installed on both sides of the platform if one (1) or both (2) sides of the platform measure more than 23'-4" (7,10 m).

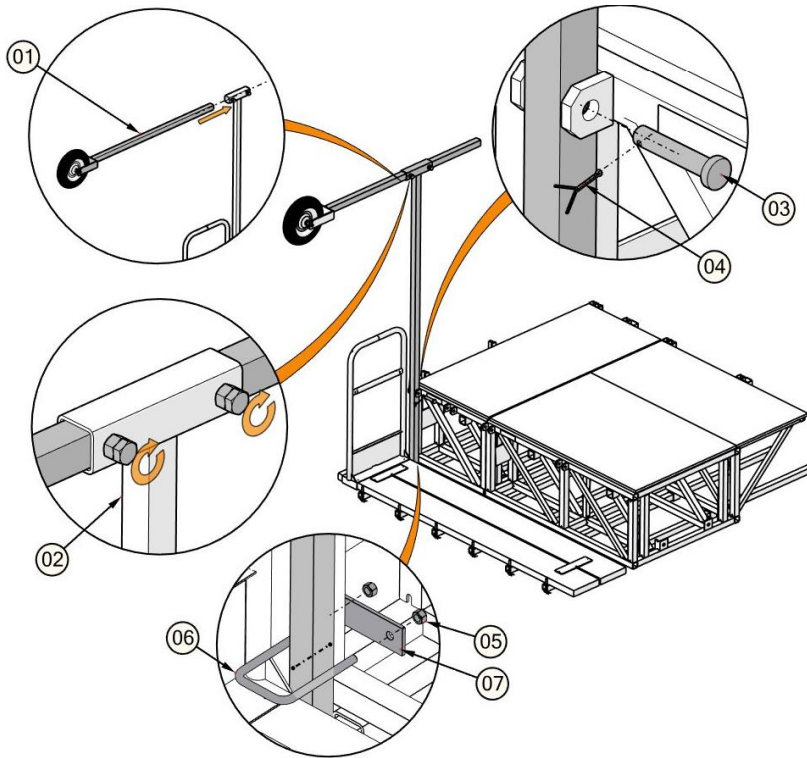


No	Item	Description	No	Item	Description
01	20490263	Outrigger 4" wheel	03	25490055	Locking pin dia. 3/4" x 4-3/16"
02	20490072	Outrigger lock 1" x 2" x 2"	04	GOU-1120	Split Pin 1/8" x 2" zinc

Figure 95 - Anti-pivot device (small wheel)

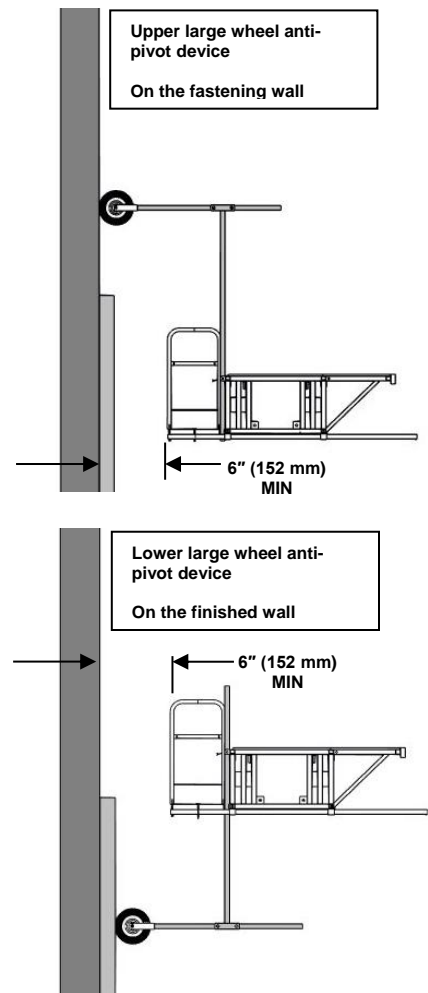
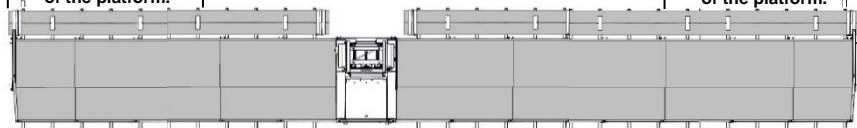
## Installing anti-pivot device, large wheel (optional)

**Important!** The anti-pivot system wheels must be installed on both sides of the platform if one (1) or both sides of the platform measure more than 23'-4" (7,10 m).



Install the wheel anywhere in the last 10'-0" (3,0 m) of the platform.

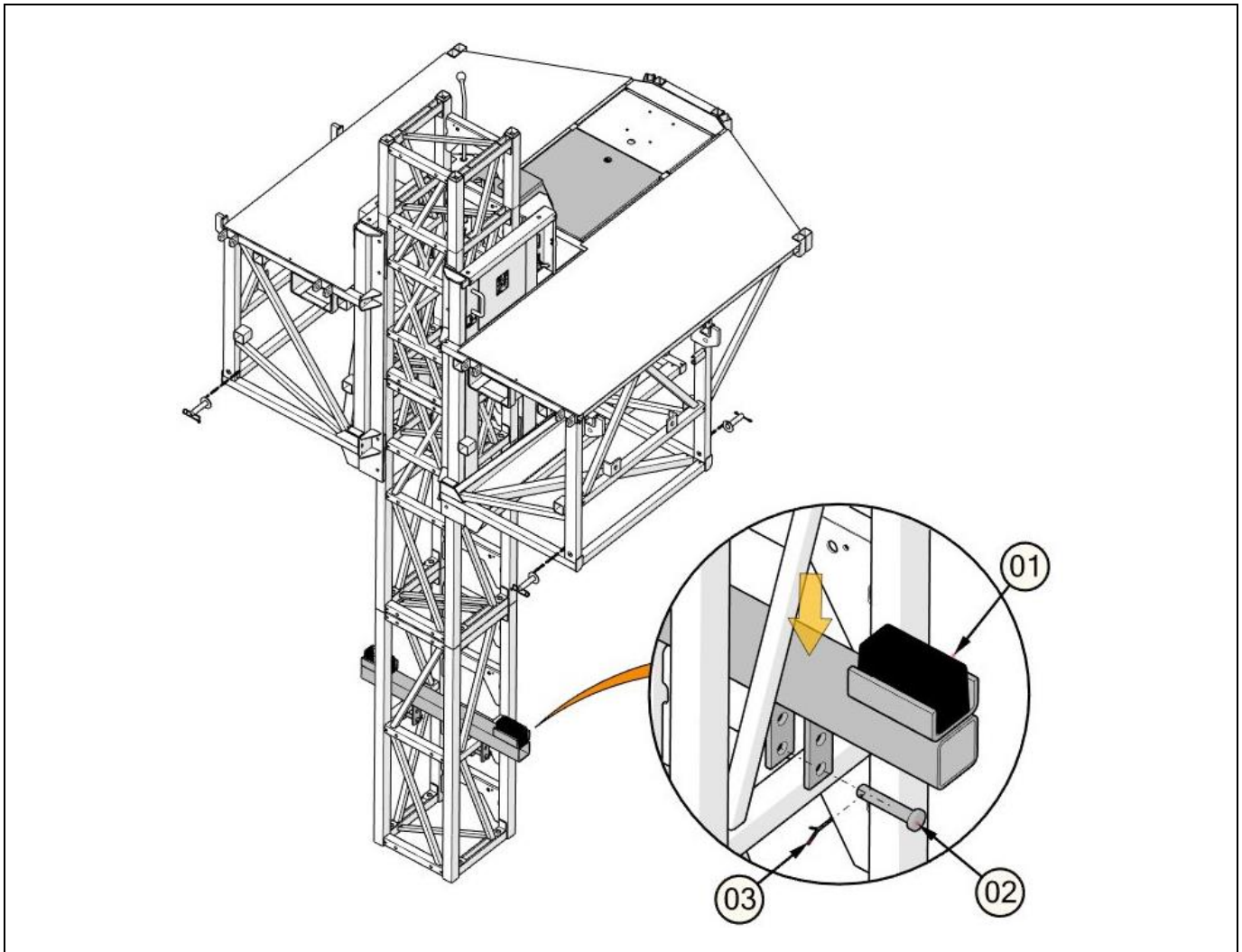
Install the wheel anywhere in the last 10'-0" (3,0 m) of the platform.



No	Item	Description	No	Item	Description
01	20491028	Wheel for single mast blocking system (over platform)	05	ECZ-8501	Nut 1/2"-13unc gr8 zinc
02	20491039	Support for single mast blocking system wheel (over platform)	06	25490101	Threaded U-shaped bolt 1/2-13unc 4-1/2" x 6-1/2"
03	25490055	Locking pin dia. 3/4" x 4-3/16"	07	20490173	Forged steel 1/4" x 2" x 6"
04	GOU-1120	Split Pin 1/8" x 2" zinc			

Figure 96 - Anti-pivot device (large wheel)

## Installation of the descent stop

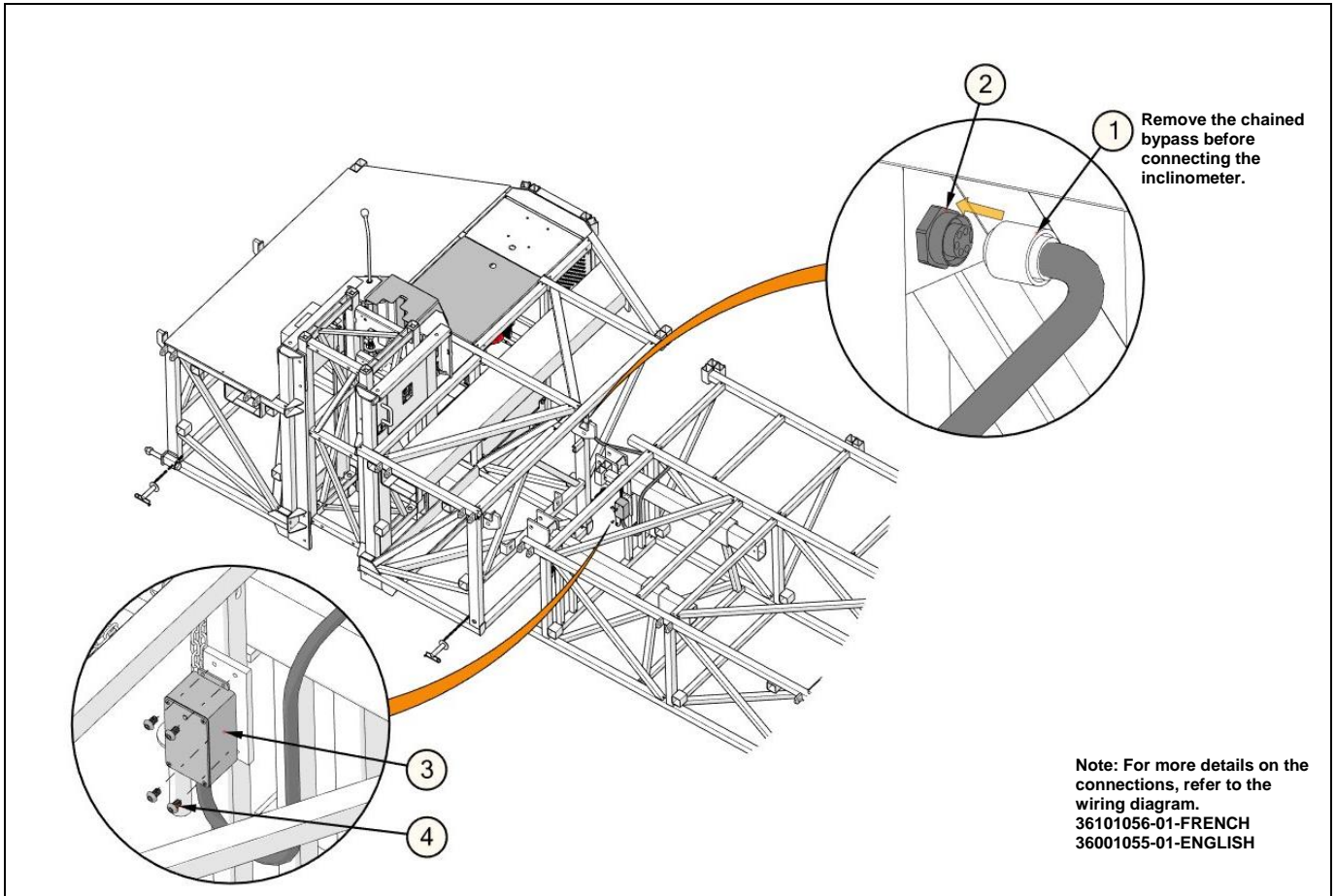


No	Item	Description	No	Item	Description
01	20490768	20" x 20" mast section descent limiting device	03	GOU-1120	Split pin 1/8" x 2" zinc
02	25490055	Locking pin dia. 3/4" x 4-3/16"			

Figure 97 - Descent stop device

### Installation of the inclinometer

**Important!** Refer to local regulations to determine if inclinometer installation is mandatory.



No	Item	Description	No	Item	Description
01	ELE-1402	5-pole auxiliary connector M with cable	03	ELE-1816	1-axis inclinometer box 5 relays 5A
02	ELE-1405	Receiver 5-pin F	04	XXXXXXXX	Screw ØM3

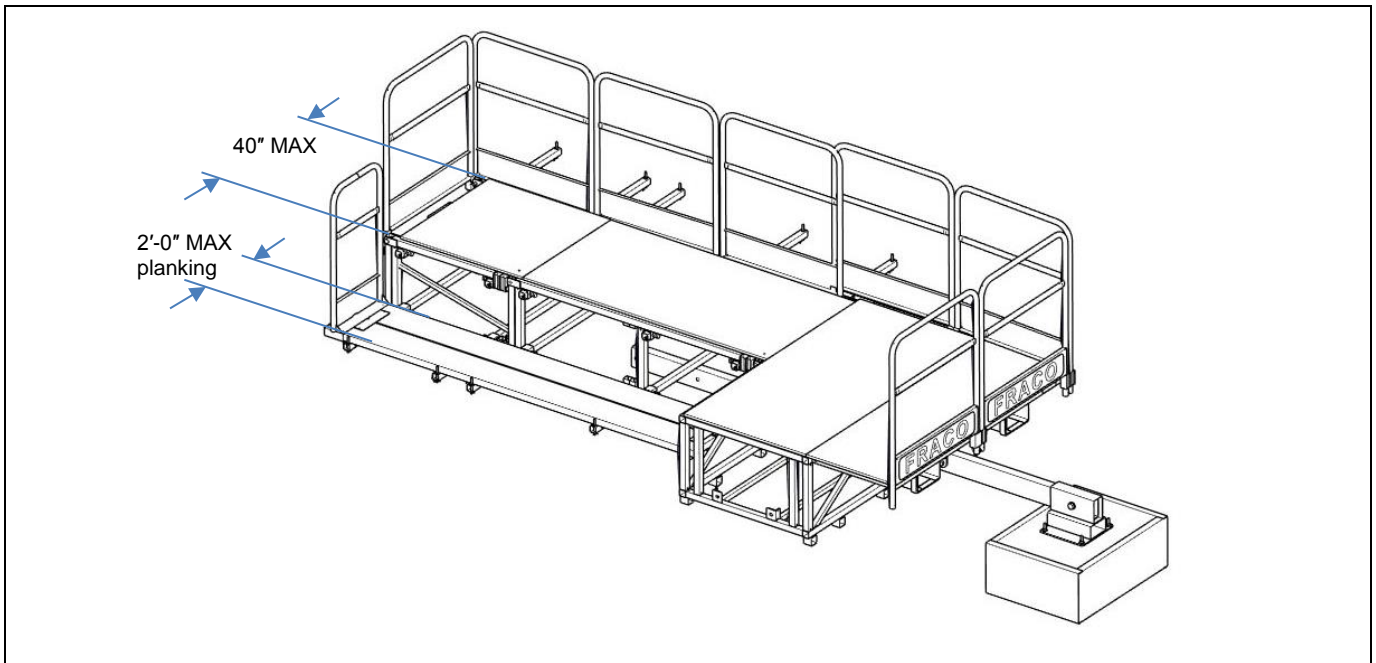
Figure 98 - Inclinometer

## Reinforced corner return support system with counterweight

**Important!** This system can only be used with certain configurations. Consult the FRACO engineering department for the required configurations.

**Important!** It is **forbidden** to use a corner return system on a freestanding base without a wall attach system.

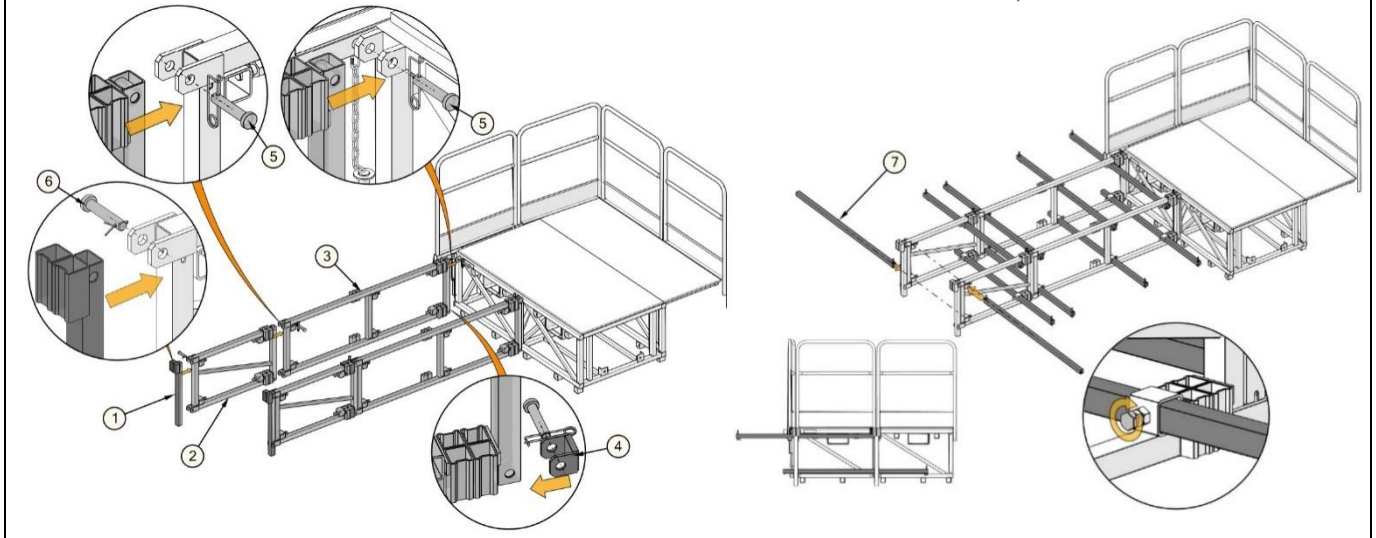
**Important!** It is **forbidden** to pass the last mast anchor if you use a corner return system with counterweight.



### Installation of work supports on an extension section

Note: Installation on a bridge section or tapered extension requires the use of a reinforced work support attachment (20491916).

∞SEE **FIGURE 102 - INSTALLATION OF WORK SUPPORTS ON TAPERED EXTENSION SECTION OR BRIDGE SECTION, ON PAGE 104**

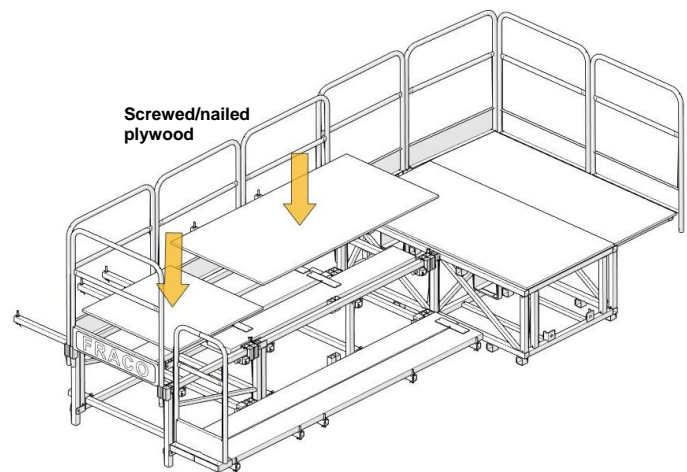
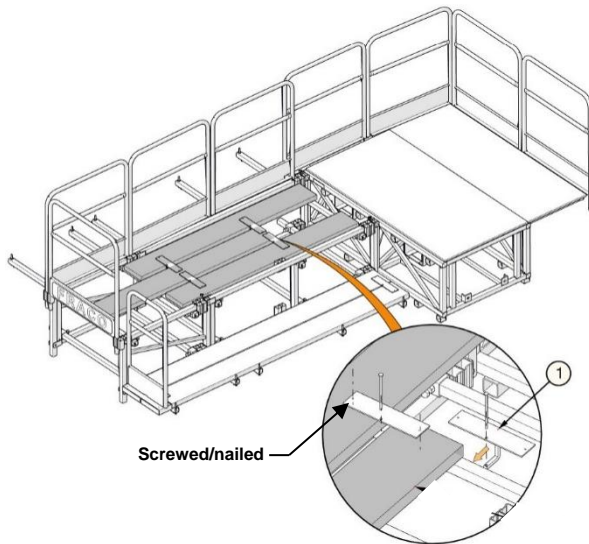
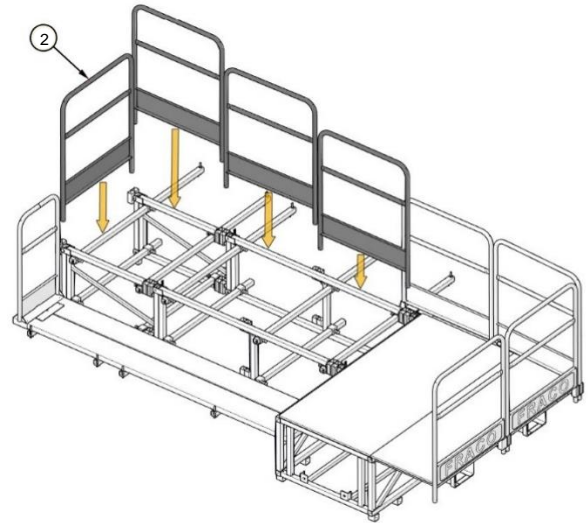
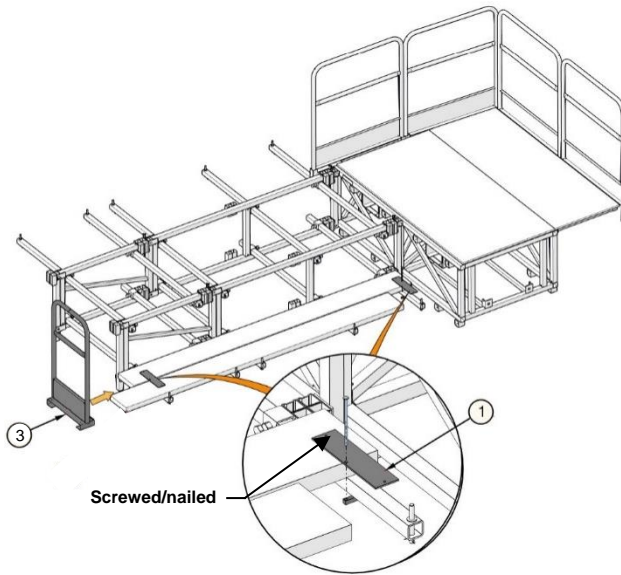


No	Item	Description	No	Item	Description
01	20490184	Guardrail pockets with 3/4" hole	05	25490055 and GOU-5020	Pin dia. 3/4" x 4-3/16" and 1/8" x 4-1/4" safety pin
02	20491893	Reinforced working support 2'-0" x 3'-4"	06	25490055 and GOU-1120	Pin dia. 3/4" x 4-3/16" and 1/8" x 2" split pin zinc
03	20491905	Reinforced working support 2'-0" x 6'-8"	07	19010089	3/16" x 2" x 2" x 6'-6" outrigger + pin 6"
04	20491927	Truss support bloc			

Figure 99 - Corner return, installation

## Reinforced corner return support system with counterweight (CONTINUED)

### Installation guardrail, plankings and finishing

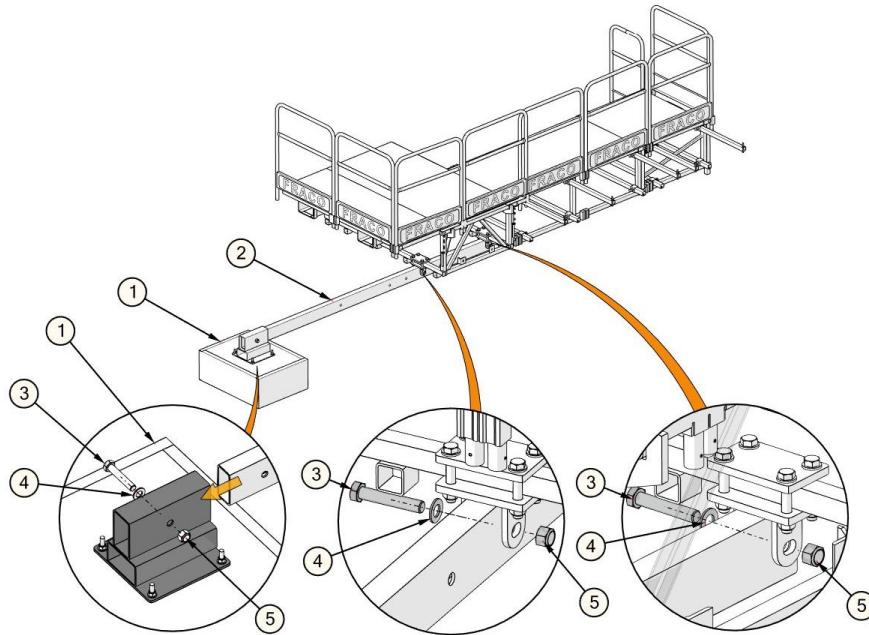
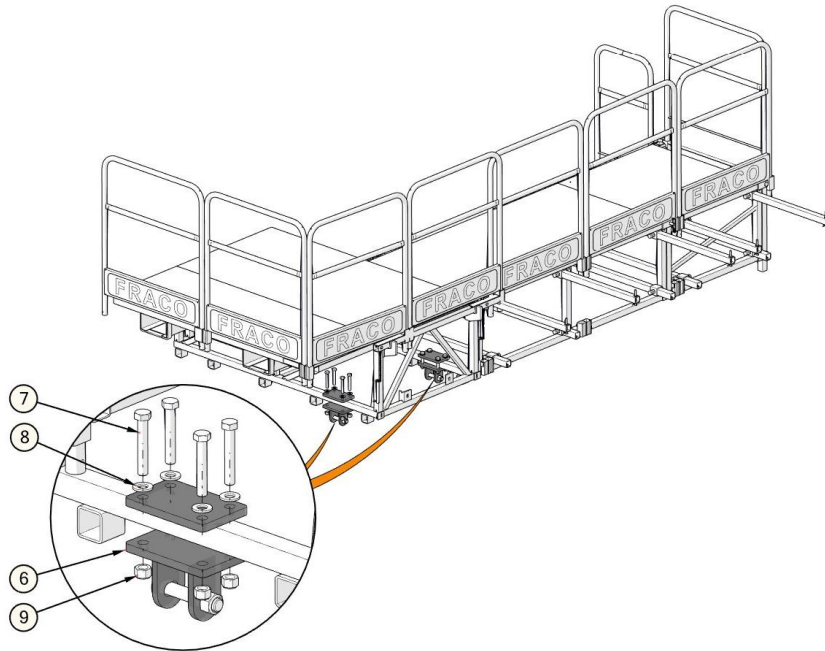


No	Item	Description	No	Item	Description
01	20490050	Plank tie 3" x 12"	03	17490045	Plank-end guard-rail 21" x 3'-6"
02	17490023	Guardrail (3'-4" x 4'-2")			

Figure 100 - Corner return, installation

## Reinforced corner return support system with counterweight (CONTINUED)

### Installation of counterweight



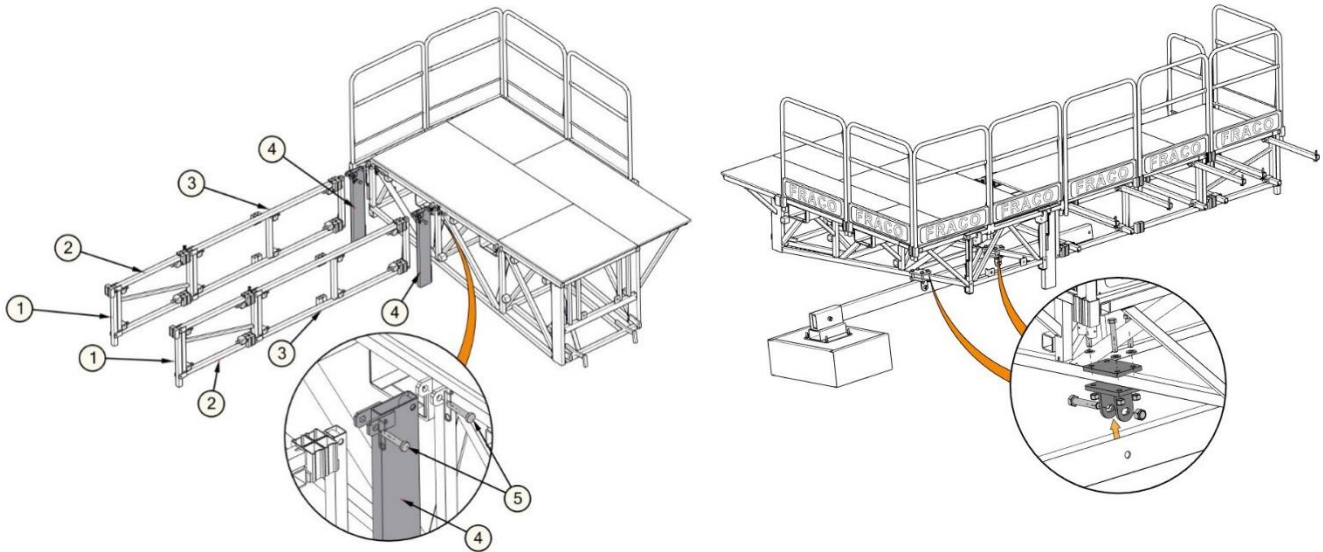
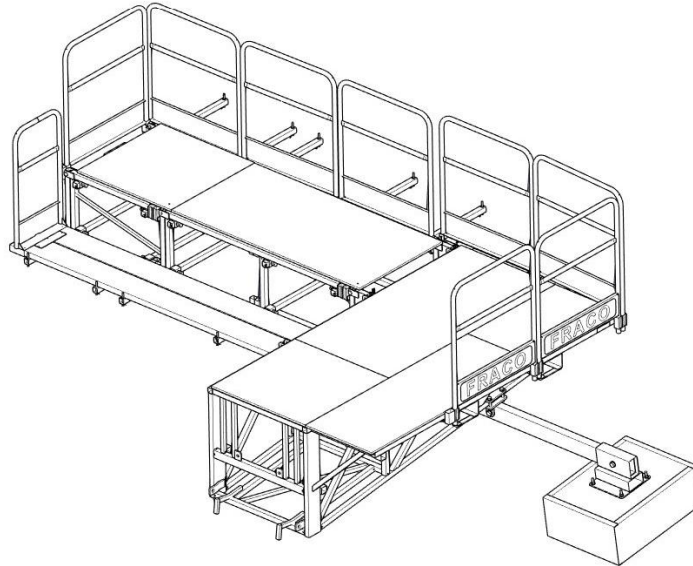
No	Item	Description	No	Item	Description
01	20491815	Counterweight 1 650 lbs 15" x 30" x 40"	06	20491871	Counterweight support tie
02	20491882	Counterweight connection tube 12'-6"	07	BOZ-7245	Bolt 3/4"-10unc x 4-1/2" gr5 zinc
03	BOZ-7262	Bolt 1"-8unc x 5-1/2" gr5 zinc	08	WAZ-7051	Washer 3/4" SAE zinc
04	WAZ-7071	Washer 1" SAE zinc	09	NYL-2050	Nylon lock nut 3/4"-10unc gr5 zinc
05	NYL-2060	Nylon lock nut 1"-8unc gr5 zinc			

Figure 101 - Corner return, installation of the counterweight



## Reinforced corner return support system with counterweight (CONTINUED)

**Installation of work supports on a bridge or tapered extension section**  
 The example shows an installation on a tapered extension section.



No	Item	Description	No	Item	Description
01	20490184	Guardrail pockets with 3/4" hole	04	20491916	Bridge Truss tie
02	20491893	Reinforced working support 2'-0" x 3'-4"	05	25490055 and GOU-5020	Lock pin dia. 3/4" x 4-3/16" and Safety pin 1/8" x 4-1/4"
03	20491905	Reinforced working support 2'-0" x 6'-8"			

**Figure 102 - Installation of work supports on tapered extension section or bridge section**

## Reinforced corner return support system with counterweight (CONTINUED)

- Reinforced work support 2'-0" (610 mm) x 3'-4" (1,0 m) (20491893)
- Reinforced work support 2'-0" (610 mm) x 6'-8" (2,0 m) (20491905)

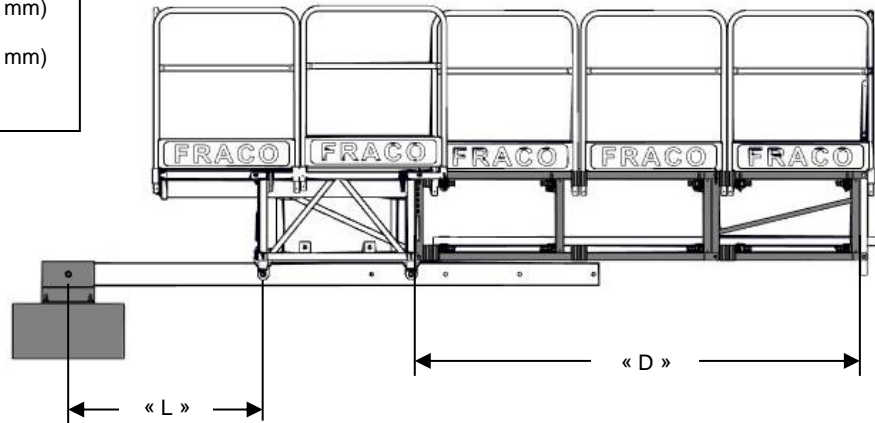


Figure 103 - Installation distance of counterweight for corner return work support

Length « D » of the combined work supports	Combination of work support sections (truss outriggers)	Distance « L » for installation of counterweights
10'-0" (3,0 m)	[6'-8"] (2,0 m) + [3'-4"] (1,0 m)	50" (1,3 m)
13'-4" (4,0 m)	[6'-8"] (2,0 m) + [3'-4"] (1,0 m) + [3'-4"] (1,0 m) or [6'-8"] (2,0m) + [6'-8"] (2,0m)	80" (2,0 m)
16'-8" (5,1 m)	[6'-8"] (2,0 m) + [3'-4"] (1,0 m) + [6'-8"] (2,0 m)	100" (2,6m)

**Important!** For the platform configurations admissible for the use of the reinforced work support system, contact the FRACO Engineering Department.

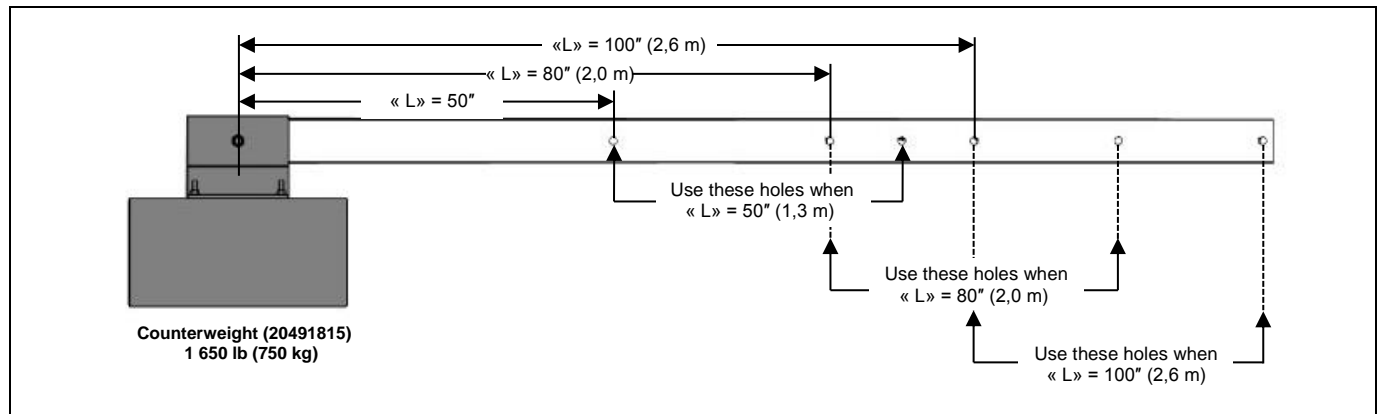


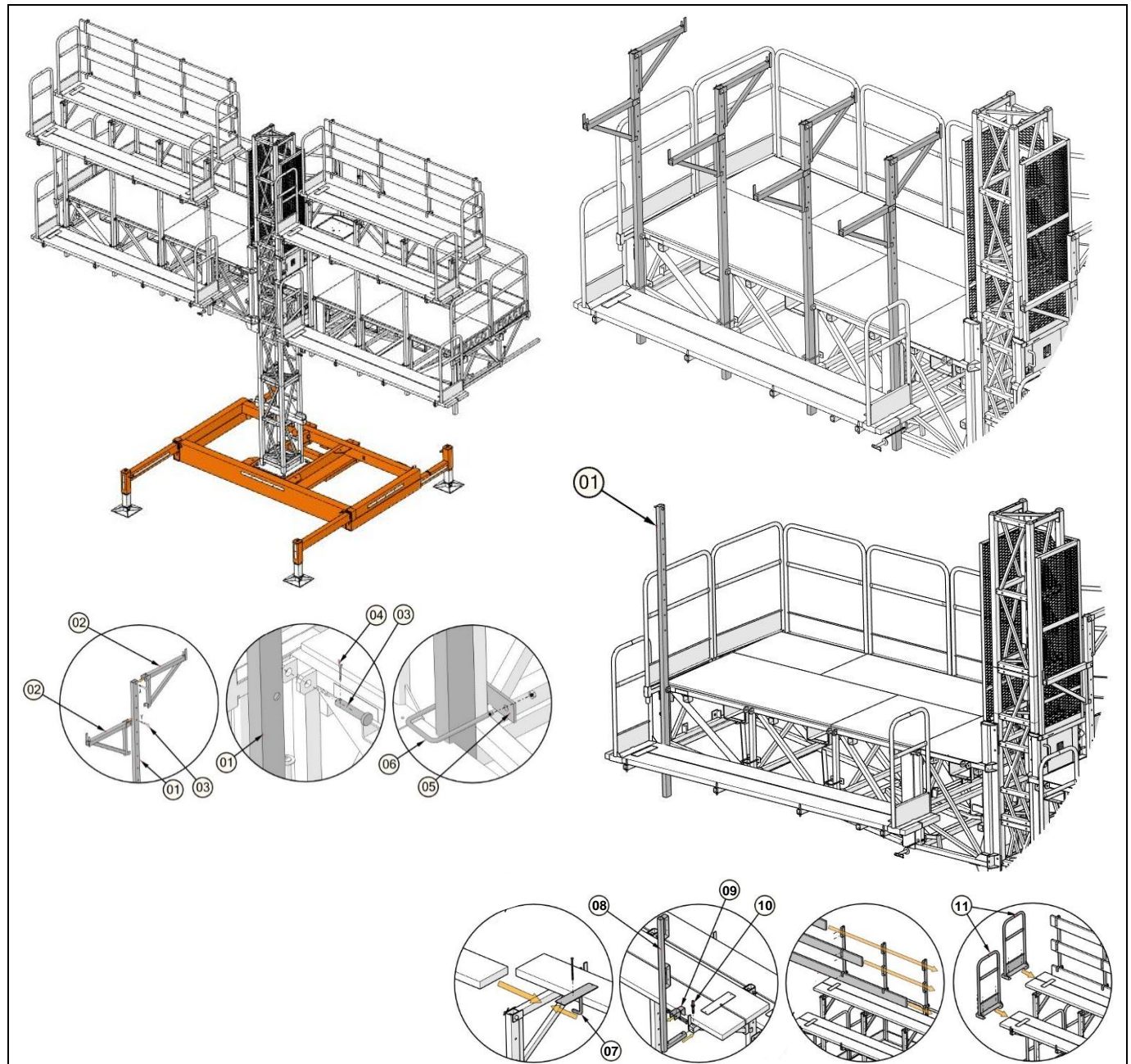
Figure 104 - Installation of counterweight outrigger

## Indoor work system

**Important!** This system can only be used with certain configurations. Contact the FRACO Engineering Department for the required configurations.

**Important!** It is **forbidden** to use an indoor working system on a freestanding base without a wall attach system.

**Important!** It is forbidden to pass the last mast anchor if you use an indoor working system.



No	Item	Description	No	Item	Description
01	20490421	Multifunctional Tube 2" x 3" x 11'-6"	07	20490050	Plank tie (3" x 12")
02	20490386	Interior work support Bracket	08	17490067	L outrigger guard-rail (4'-3")
03	25490055	Pin (dia. 3/4" x 4-3/16")	09	20491646	« L » guard-rail sliding tie
04	GOU-1120	Split Pin 1/8" x 2" zinc	10	25490066	Pin with washer (dia. 1/2" x 4-3/4")
05	20490173	Forge steel (1/4" x 2" x 6")	11	17490045	Plank-end guard-rail (21" x 3'-6")
06	25490101	Threaded U-lock 1/2-13unc (4-1/2" x 6-1/2")			

Figure 105 - Installing the indoor working system

## Rigid roof system

**Important!** This system can only be used with certain configurations. Contact the FRACO engineering department for the required configurations.

**Important!** It is **forbidden** to use a rigid roof system on a freestanding base without a wall attach system.

**Important!** It is **forbidden** to pass the last mast anchor if you use a rigid roof system

Inclination of the roof may be adjusted as needed. Refer to the positioning of the supports in a horizontal or inclined position.

∞SEE FIGURE 107 - RIGID ROOF SYSTEM, INSTALLATION OF SUPPORTS, ON PAGE 108.

It is strongly recommended to use a FIRE DELAYING bulkhead in compliance with local applicable standards.

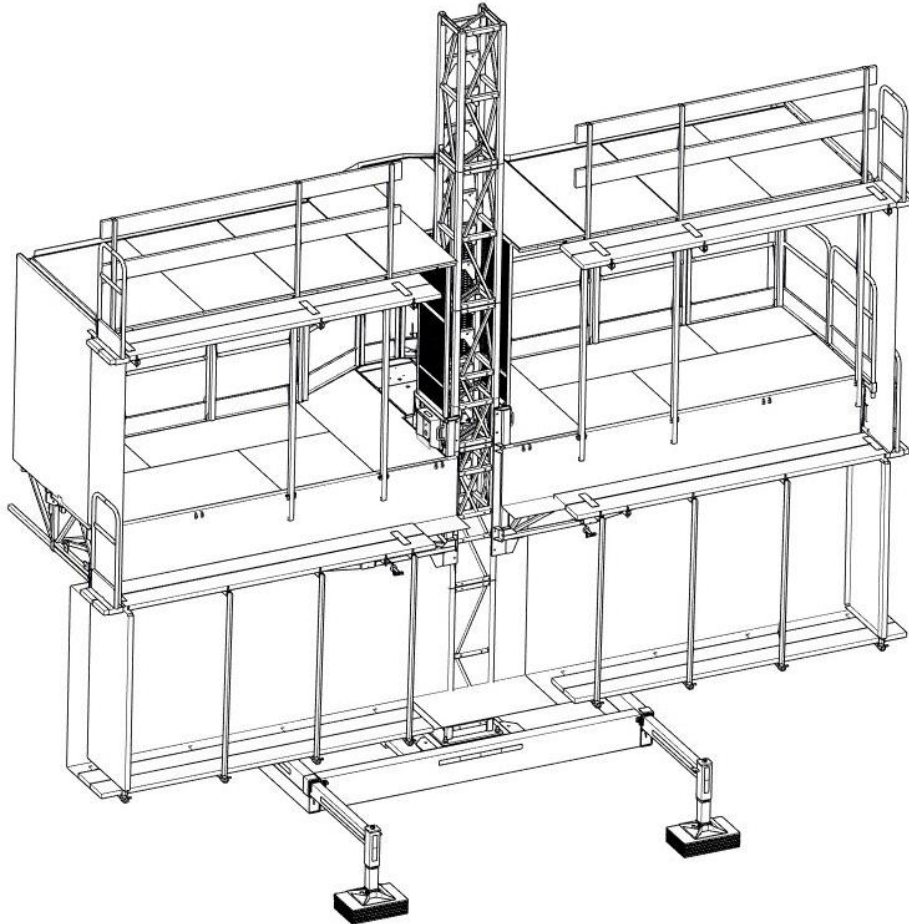
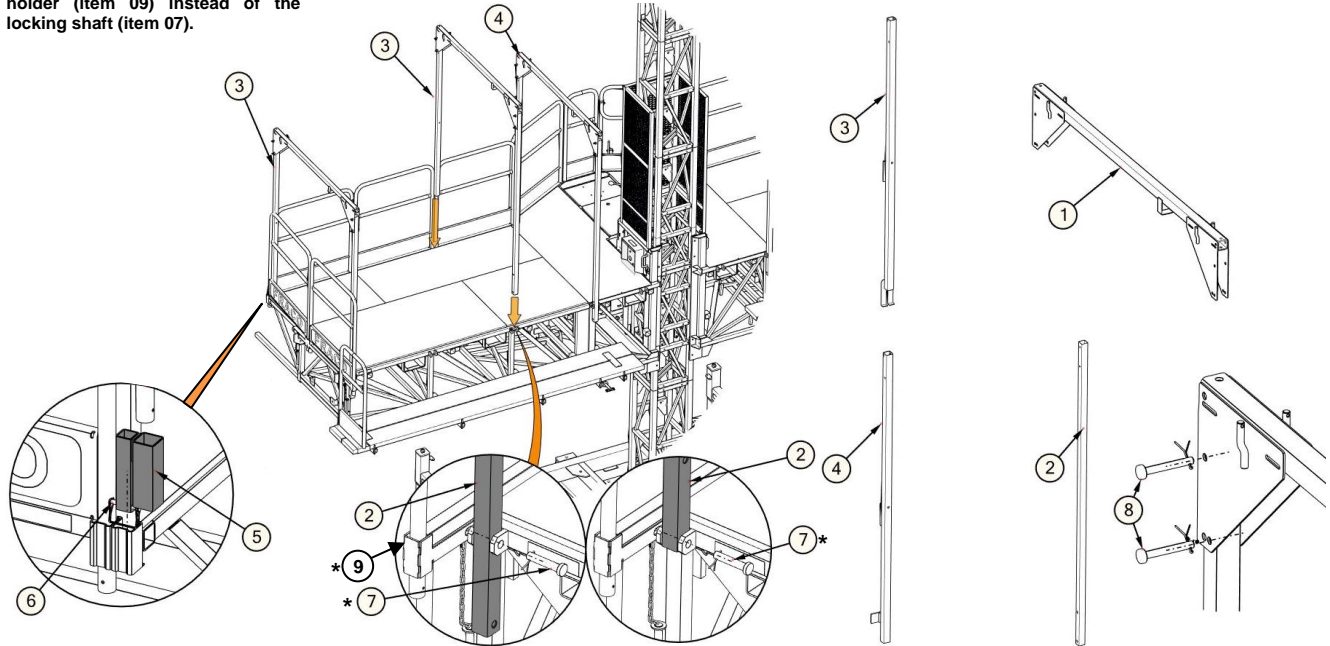


Figure 106 - Rigid roof system

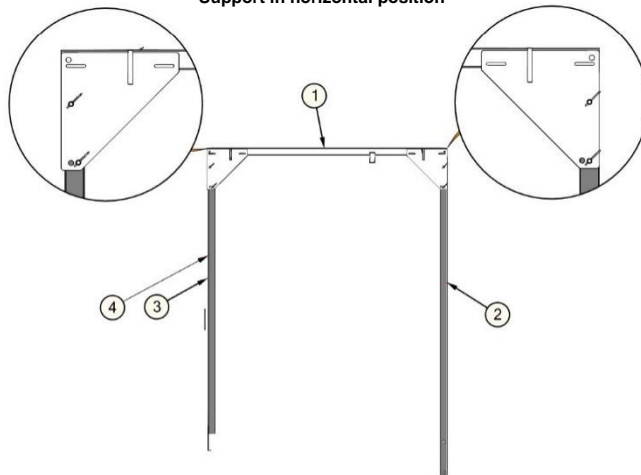
## Rigid roof system (CONTINUED)

### Installation of the rigid roof structure

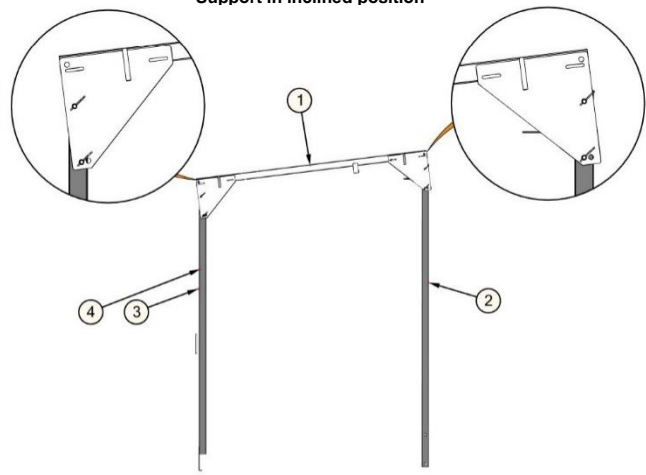
\* **Note:** At the edge of the extension section, use the chain pin supplied with the railing pocket holder (item 09) instead of the locking shaft (item 07).



Support in horizontal position



Support in inclined position

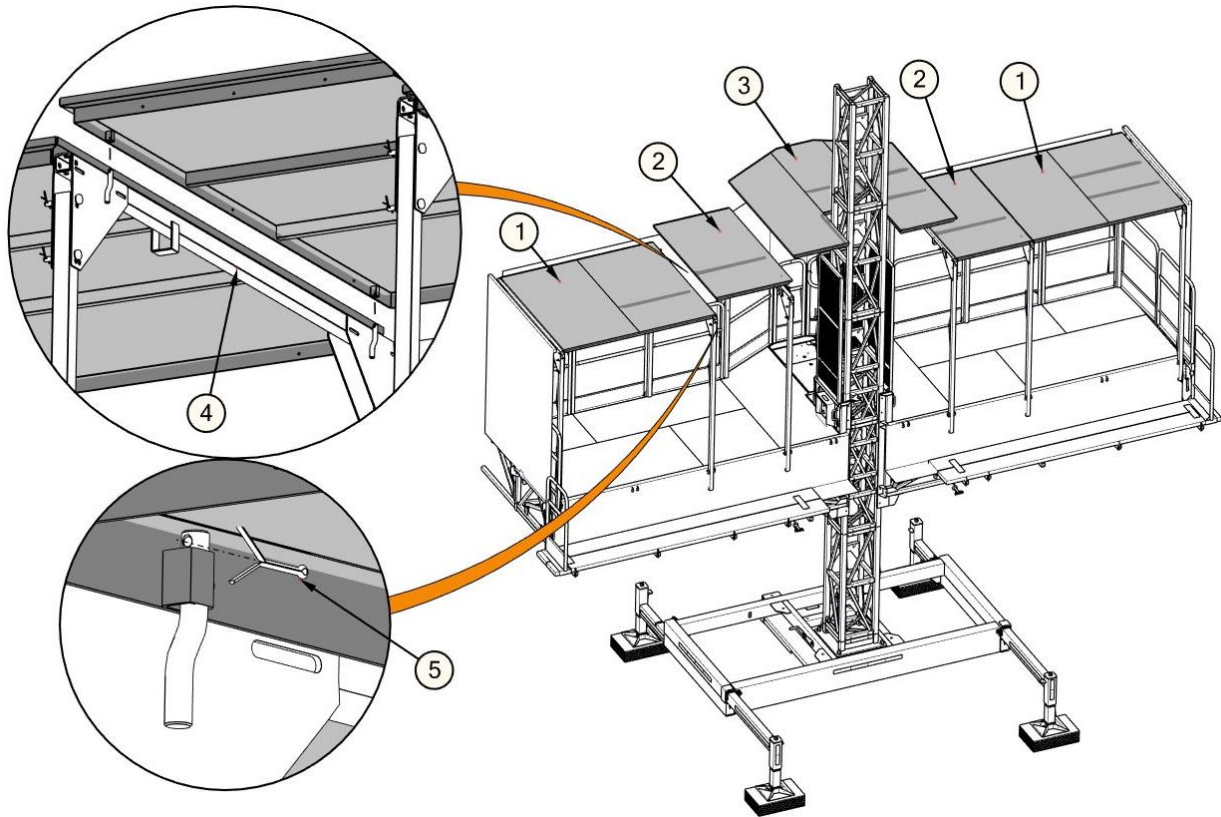


No	Item	Description	No	Item	Description
01	26010223	Cross support for rigid roof	06	GOU-5040	Locking pin 3/8" x 2-1/2" x 1-1/2"
02	26010188	Rigid front roof support	07*	25490055 and GOU-1120	Pin (dia. 3/4" x 4-3/16") and 1/8" x 2" split pin zinc
03	26010234	Back support for rigid roof	08	25490022 and GOU-1120	Pin (dia. 1/2" x 4-1/8") and Split Pin 1/8" x 2" zinc
04	26010245	ACT-8's back support for rigid roof	09*	20490195	Guardrail sockets for 3'-6" extension
05	26010199	Guard-rail adaptor			

Figure 107 - Rigid roof system, installation of supports

## Rigid roof system (CONTINUED)

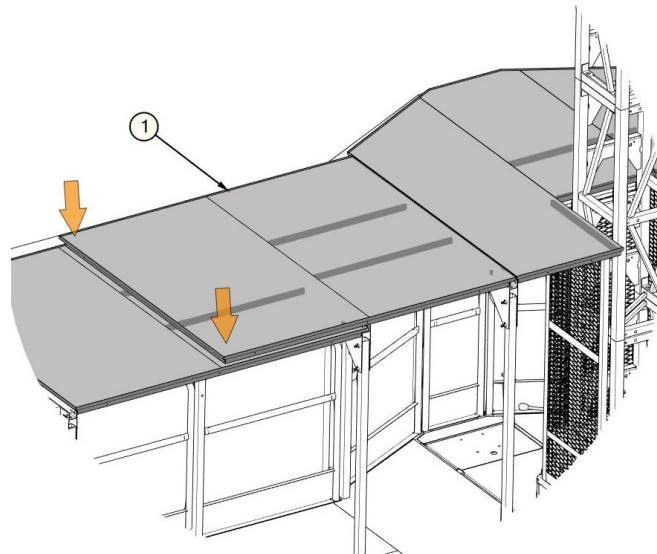
### Installation of plywood supports



### Installation of plywood supports on a bridge section

When installing over a bridge section, simply install the plywood support near the unit over the neighboring support.

This type of installation is necessary to follow the pivot movement of the bridge arms.



No	Item	Description	No	Item	Description
01	26010212	Flooring support 6'-8" x 5'-11"	04	26010223	Cross support for rigid roof
02	26010201	Flooring support 3'-4" x 5'-11"	05	GOU-1120	Split Pin 1/8" x 2" zinc
03	26020088	Plywood support 7'-3" x 7'-6" 20K			

Figure 108 - Rigid roof system, installation of plywood supports

## Rigid roof system (CONTINUED)

### Installation of the canvas partitioning

**Important!** Canvases not included, suggested presentation. The canvases must be supplied by the contractor.

Slide the canvas segments under the planking of the work areas.

Install the canvas partitioning on the outside of the platform. Tackle / nail to plywood or use wooden slats.

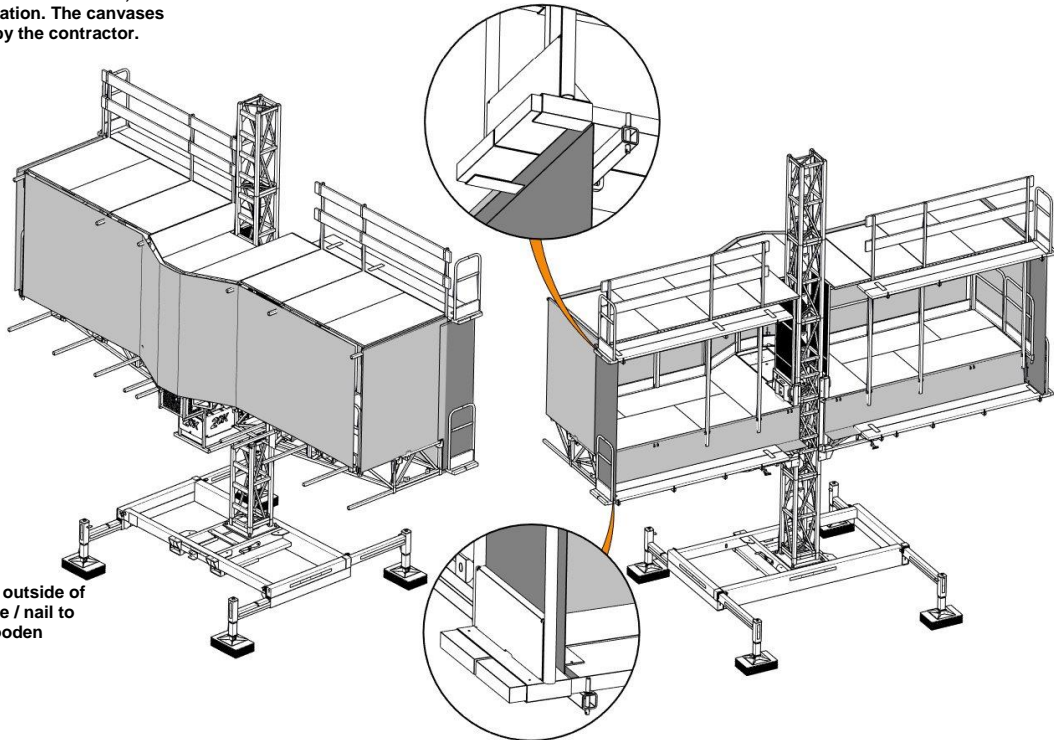
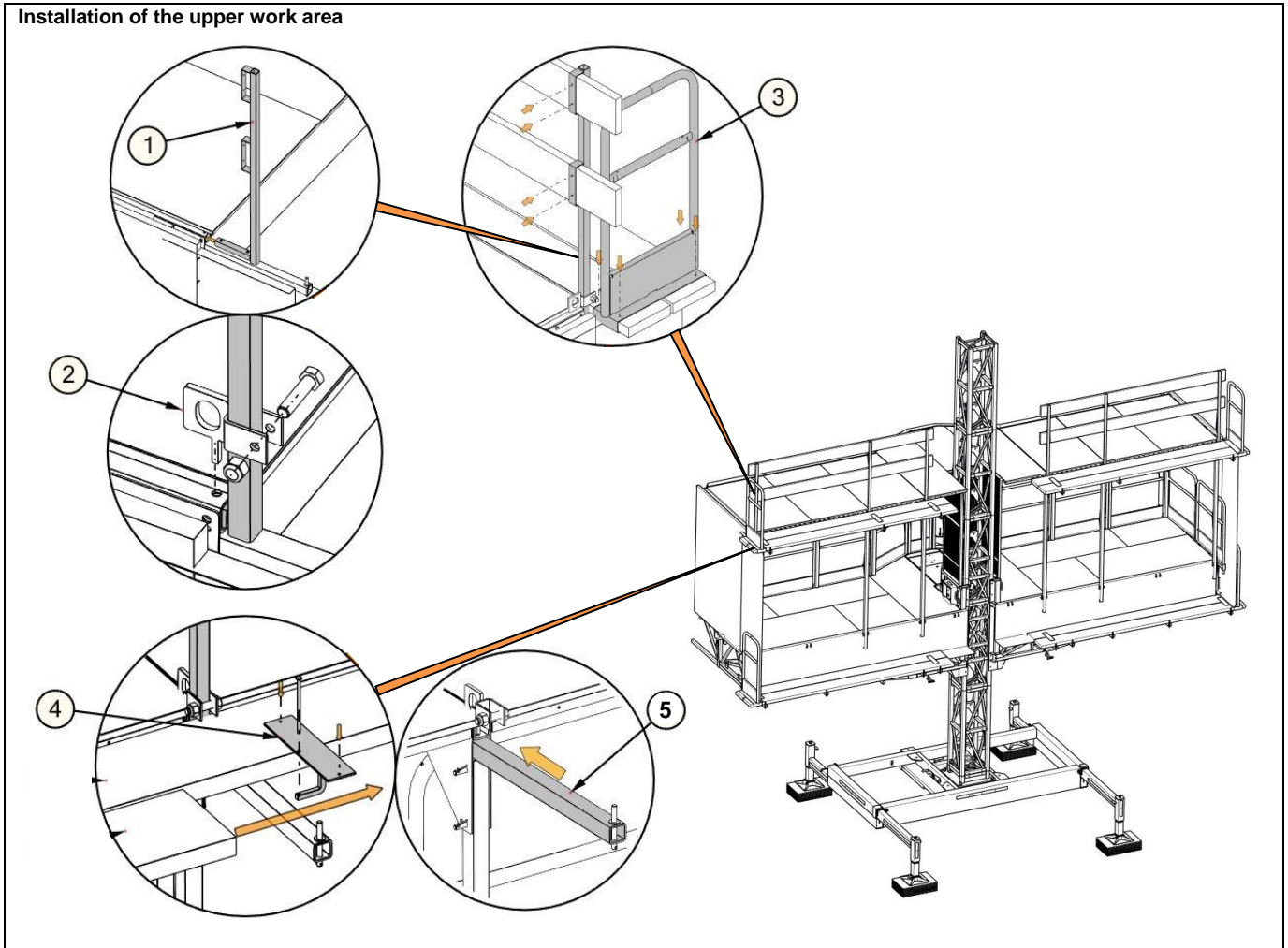


Figure 109 - Rigid roof system, installation of canvas partitions

## Rigid roof system (CONTINUED)



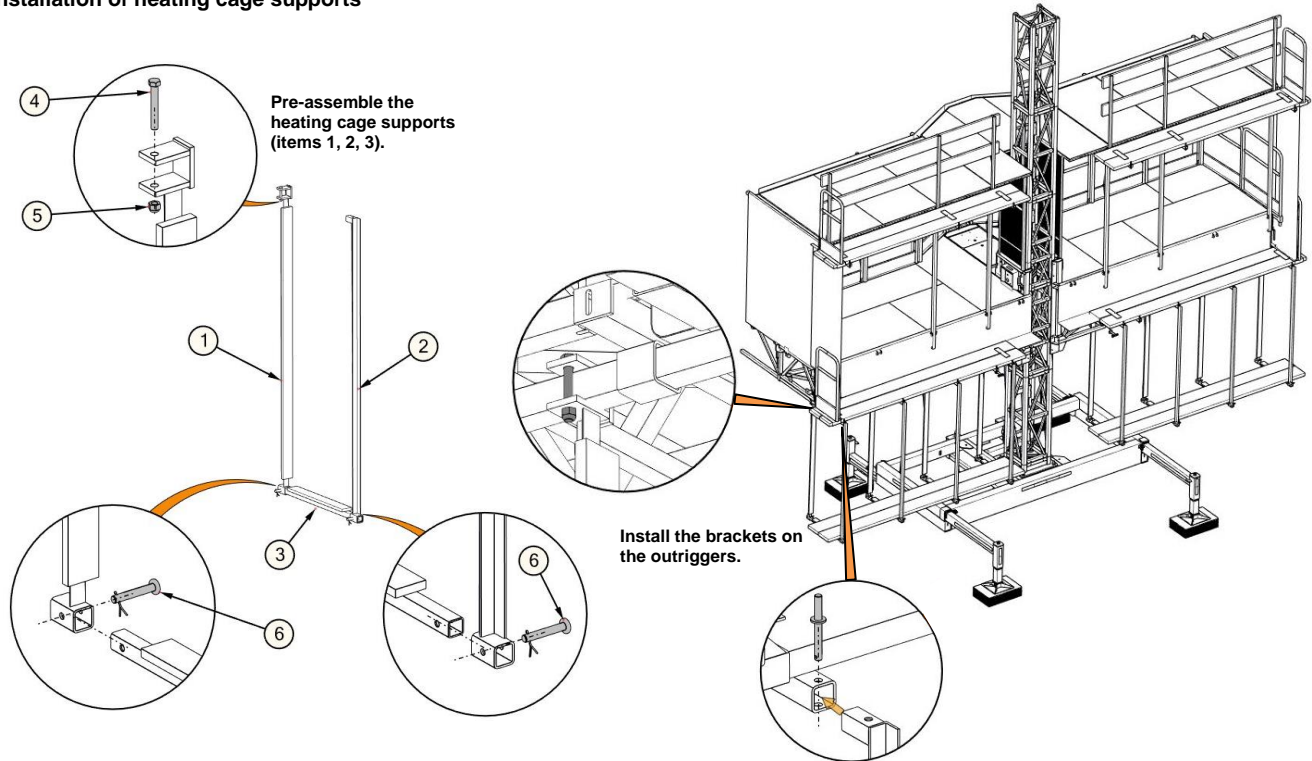
No	Item	Description	No	Item	Description
01	17490067	L outrigger guard-rail 4'-3"	04	20490050	Plank tie 3" x 12"
02	20490780	Tie for L outrigger guard-rail on roof	05	19010034	Outrigger 3/16" x 2" x 2" x 8'-8"
03	17490045	Plank-end guard-rail 21" x 3'-6"			

Figure 110 - Rigid roof system, upper work area



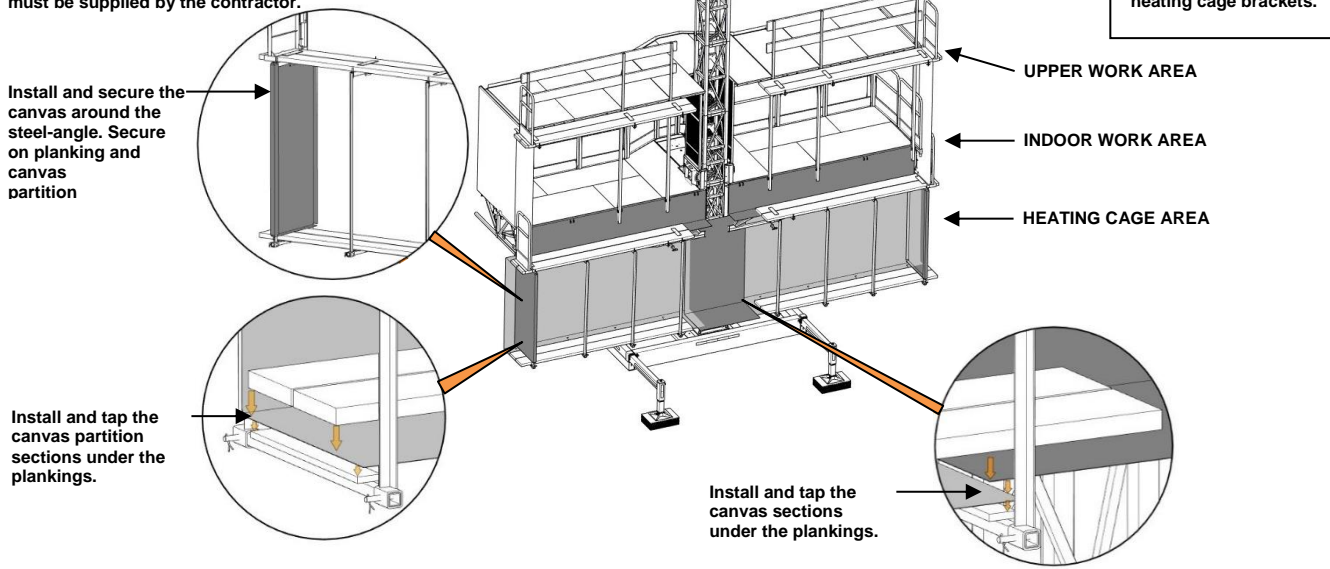
## Rigid roof system (CONTINUED)

### Installation of heating cage supports



### Installation of canvas, plankings and finishing

**Important!** Canvases not included, suggested presentation. The canvases must be supplied by the contractor.



No	Item	Description	No	Item	Description
01	26010021	Heating cage tube with plywood 6'-10"	04	BOZ-7185	Bolt 1/2"-13unc x 3-1/2" gr5 zinc
02	26010032	Heating cage tube with tube 6'-9"	05	NYL-2030	Nylon lock nut 1/2"-13unc gr5 zinc
03	26010043	Heating cage tube with plywood 3'-0"	06	25490044 and GOU-1120	Pin dia. 5/8" x 4-3/16" and Split Pin 1/8" x 2" zinc

Figure 111 - Rigid roof system, heating cage

## Winter shelter system

**Important!** This system can only be used with certain configurations. Consult the FRACO Engineering Department for the required configurations.

**Important!** It is **forbidden** to use a winter shelter system on a freestanding base without a wall attach system.

**Important!** It is **forbidden** to pass the last mast anchor if you use a winter shelter system.

**Important!** Canvases not included, suggested presentation. The canvases must be supplied by the contractor.

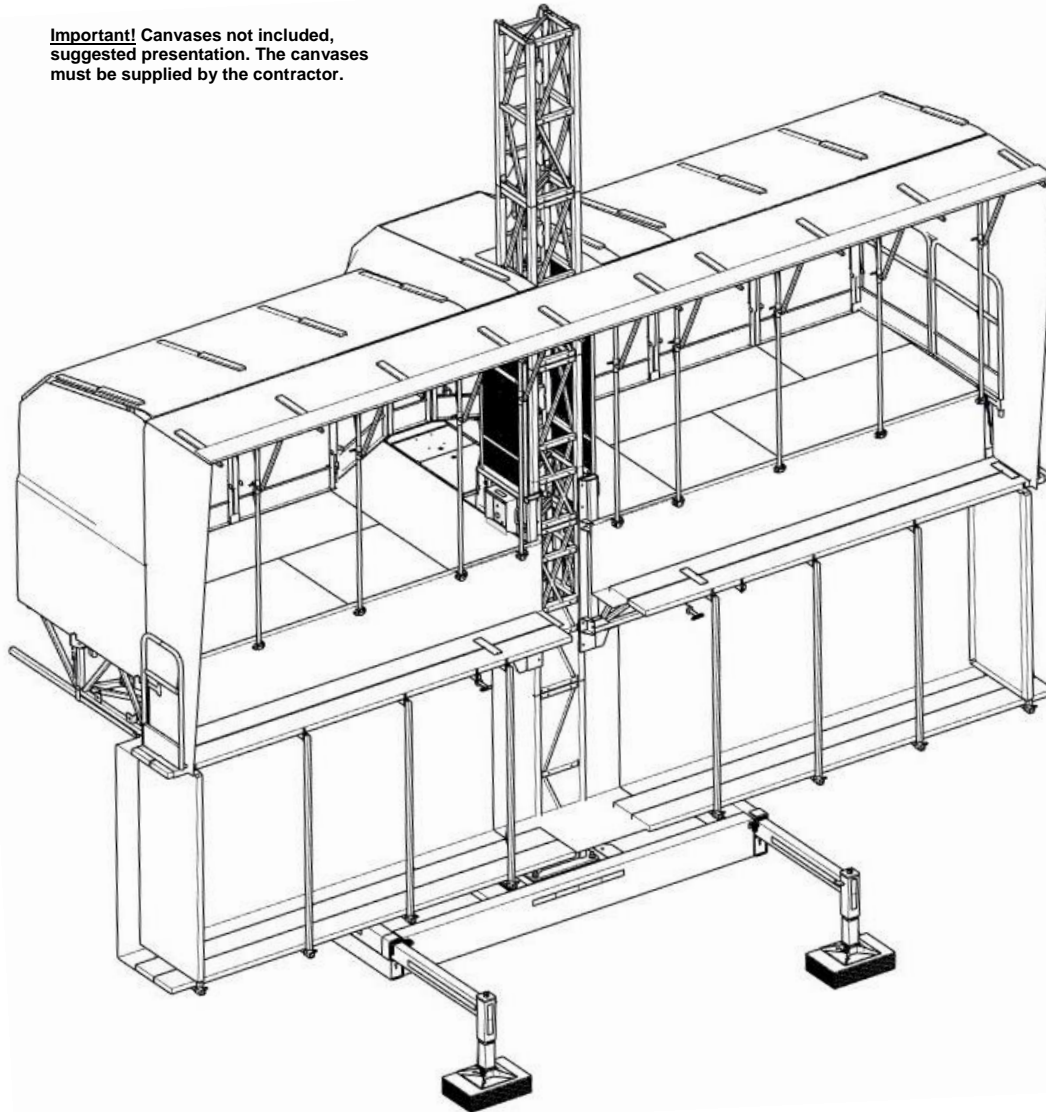
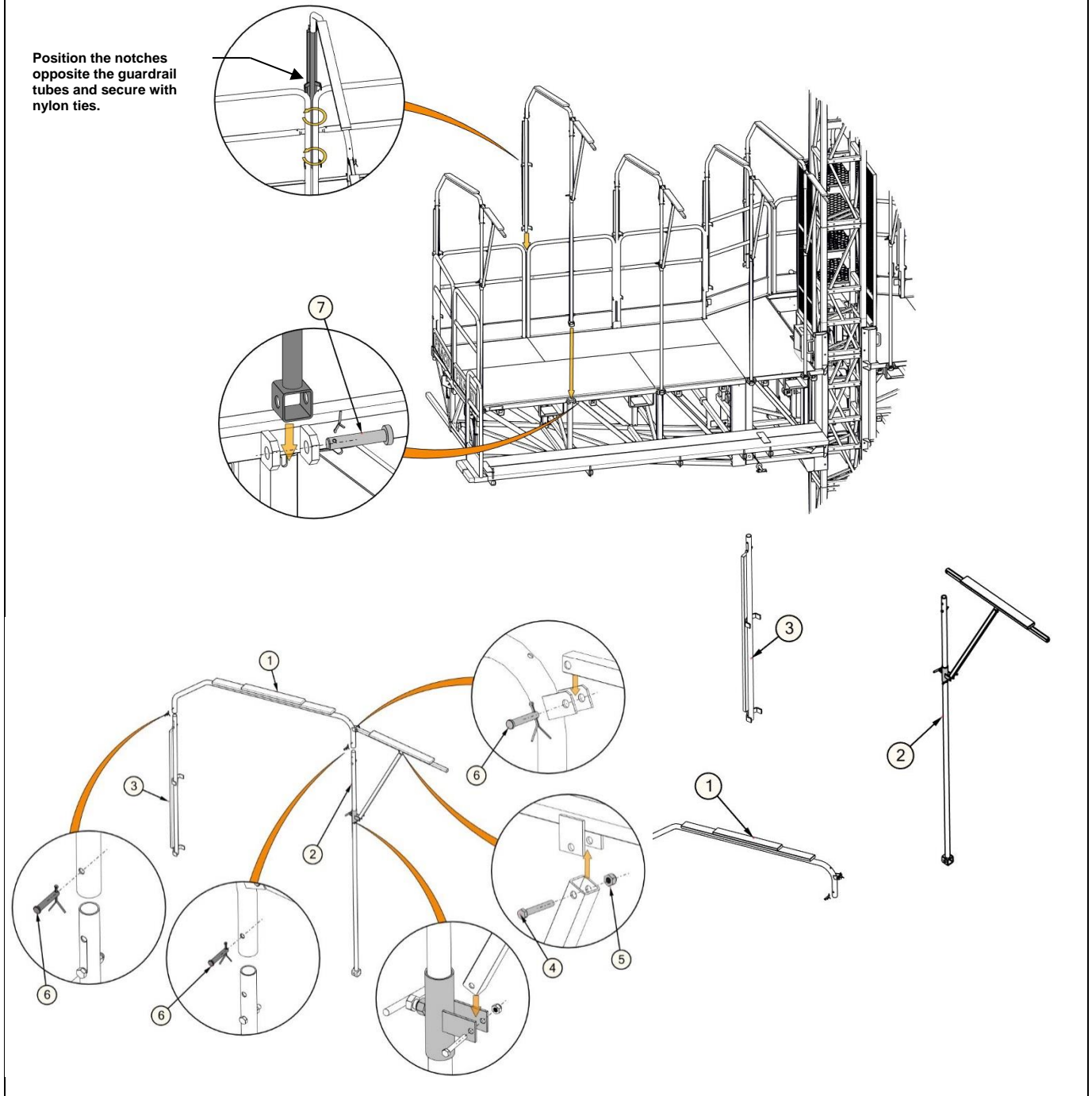


Figure 112 - Winter shelter system

## Winter shelter system (CONTINUED)

### Installation of the structure



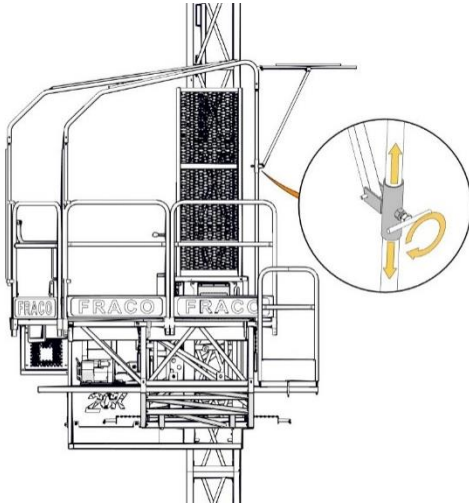
No	Item	Description	No	Item	Description
01	26010100	« U » Enclosure tube 5'-11"	05	NYL-2010	Nylon lock nut 1/4"-20unc gr5 zinc
02	26010098	Enclosure tube with 2 holes	06	FOD-5058	Screed axle 3/8" x 1-7/8"
	26010076	Enclosure tube with 2 plates			
	26010087	Enclosure 40" tube			
	28491284	Winter shelter support ring			
03	26010065	Enclosure tube with 2 plates 4'-9"	07	25490055	Pin (dia. 3/4" x 4-3/16")
04	BOZ-7030	Bolt 1/4"-20unc x 1-3/4" gr5 zinc			

Figure 113 - Winter shelter system, installation of supports

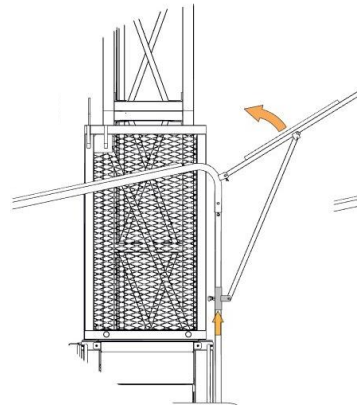
## Winter shelter system (CONTINUED)

### Supports configuration

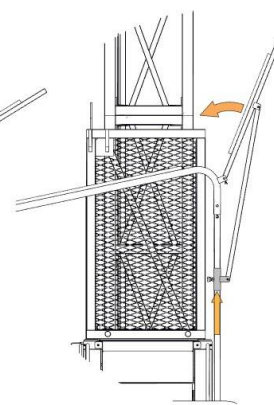
Installation at 90°



Installation at 120°



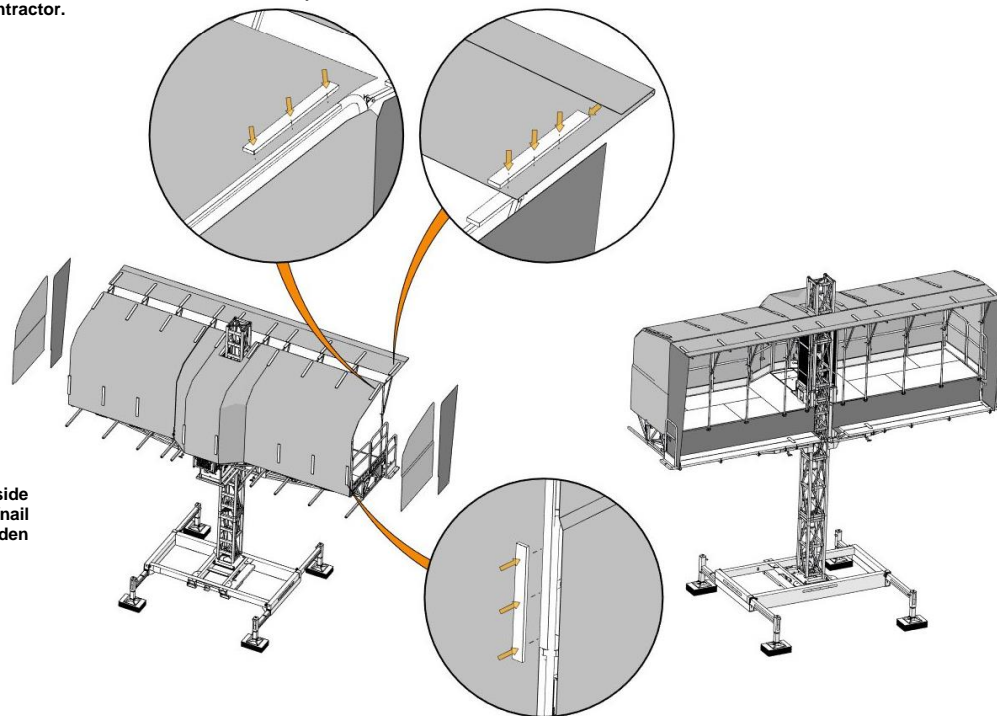
Installation at 165°



### Installation of canvas partitioning

**Important!** Canvases not included, suggested presentation. The canvases must be supplied by the contractor.

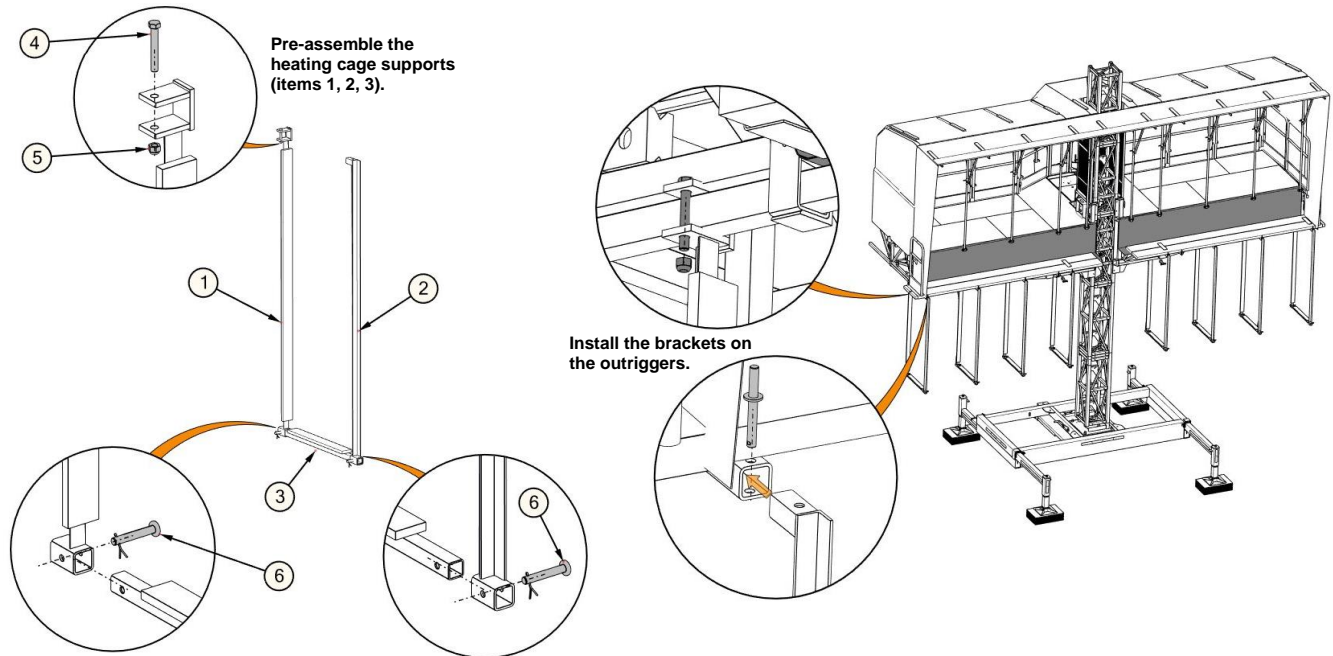
Install and screw the canvas sections between two (2) pieces of wood



Install the canvas partitioning on the outside of the platform. Tackle/nail to plywood or use wooden slats.

## Winter shelter system (CONTINUED)

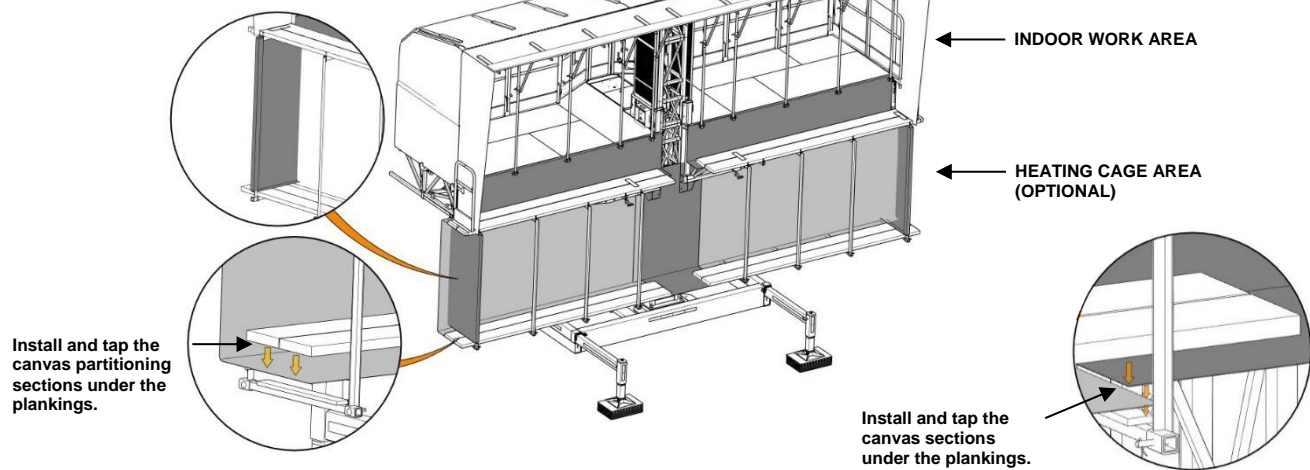
### Installation of heating cage supports



### Installation of canvas, plankings and finishing

**Important!** Canvases not included, suggested presentation. The canvases must be supplied by the contractor.

Screw/nail the plankings into the heating cage brackets.



No	Item	Description	No	Item	Description
01	26010021	Heating cage tube with plywood 6'-10"	04	BOZ-7185	1 Bolt 1/2"-13unc x 3-1/2" gr5 zinc
02	26010032	Heating cage tube with tube 6'-9"	05	NYL-2030	1 Nylon lock nut 1/2"-13unc gr5 zinc
03	26010043	Heating cage tube with plywood 3'-0"	06	25490044 and GOU-1120	Pin dia. 5/8" x 4-3/16" and Split Pin 1/8" x 2" zinc

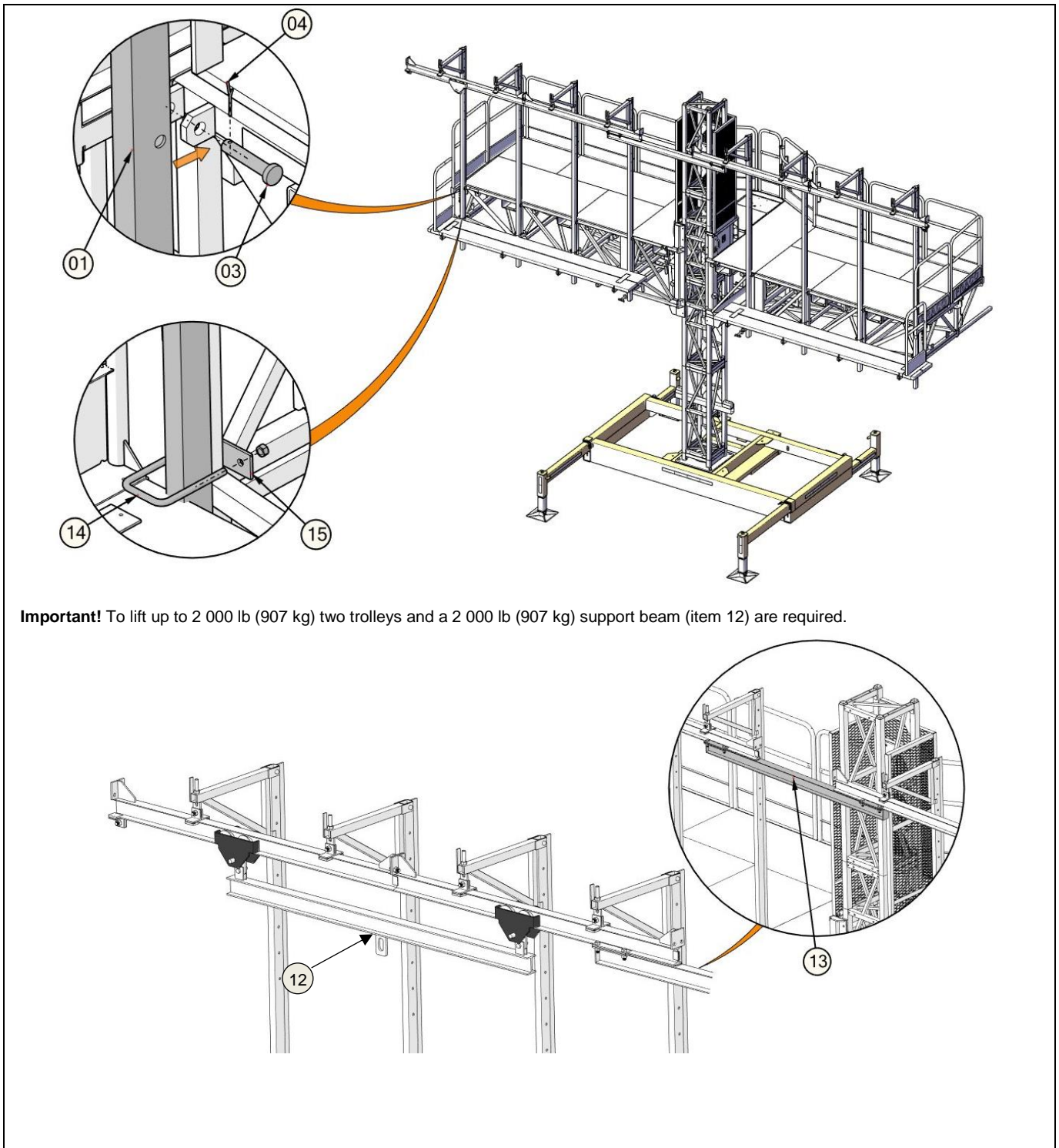
Figure 114 - Winter shelter, heating cage

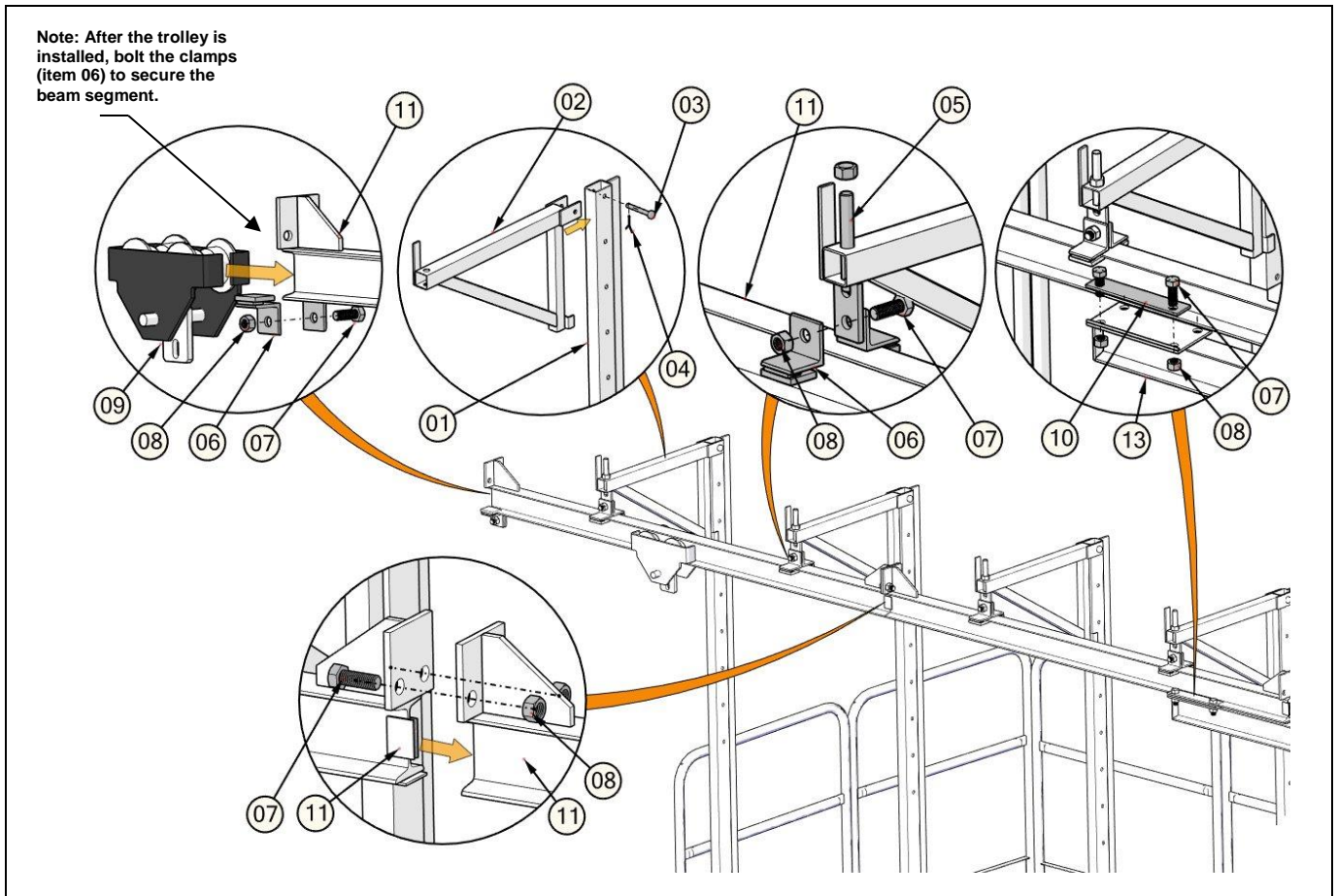
## Monorail on platform

**Important!** This system can only be used with certain configurations. Contact the FRACO engineering department for the required configurations.

**Important!** It is **forbidden** to use a monorail system on a freestanding base without a wall attach system.

**Important!** It is **forbidden** to pass the last mast anchor if you use a monorail system.





No	Item	Description	No	Item	Description
01	20490421	Multifunctional Tube 2" x 3" x 11'-6"	09	FOD-1098	Trolley 1/2 NPT for « I » beam 4" x 7,7 lb-ft
02	20490386	Interior work support Bracket	10	20490814	Tightning plate for junction beam
03	25490055	Pin dia. 3/4" x 4-3/16"	11	20490375	« I » beam 4" x 7' 0" x 7,7 lbs/pi
04	GOU-1120	Split Pin 1/8" x 2" zinc	12	20491107	Support beam for 2000lbs
05	20490274	Threaded planking beam support	13	20490207	Junction « I » beam 4" x 7'-0" x 7,7 lbs/pi
06	20490296	Beam clamp	14	25490101	Threaded U-lock 1/2-13unc 4-1/2" x 6-1/2"
07	BOZ-7225	Bolt 3/4"-10unc x 2" gr5 zinc	15	20490173	Forge steel 1/4" x 2" x 6"
08	ECZ-7080	Nut 3/4"-10unc gr5 zinc			

Figure 115 - Monorail installation

## Monorail components 500 lb (227 kg) - Extension

Item	Description	Extension length						Unit
		3'-4" (1 m)	6'-8" (2 m)	10'-0" (3 m)	13'-4" (4 m)	16'-8" (5 m)	20'-0" (6 m)	
20490173	Forge steel 1/4" x 2" x 6"	2	2	2	3	3	3	-
20490207	Junction (I) beam 4" x 7'-0" x 7,7 lbs/pi	-	-	-	-	-	-	1
20490218	(I) beam 4" x 10'-0" x 7,7 lbs/pi	0	1	1	1	1	2	-
20490375	(I) beam 4" x 7'-0" x 7,7 lbs/pi	1	0	0	1	1	0	-
20490274	Threaded beam clamp support	2	2	2	3	3	3	-
20490296	Beam clamp	3	3	3	4	4	4	-
20490386	Interior work support Bracket	2	2	2	3	3	3	-
20490421	Multifunctional Tube 2" x 3" x 11'-6"	2	2	2	3	3	3	-
20490814	Tightening plate for junction beam	-	-	-	-	-	-	4
25490022	Pin dia. 1/2" x 4-1/8"	2	2	2	3	3	3	-
25490055	Pin dia. 3/4" x 4-3/16"	2	2	2	3	3	3	-
25490101	Threaded U-lock 1/2-13unc 4-1/2" x 6-1/2"	2	2	2	3	3	3	-
BOA-2025	Bolt 3/4"-10unc x 2" A325 galv. assembled	3	3	3	4	4	4	8
GOU-1120	Split Pin 1/8" x 2" zinc	4	4	4	6	6	6	-

## Monorail components 1 000 lb (454 kg) - Extension

Item	Description	Extension length						Unit
		3'-4" (1 m)	6'-8" (2 m)	10'-0" (3 m)	13'-4" (4 m)	16'-8" (5 m)	20'-0" (6 m)	
20490173	Forge steel 1/4" x 2" x 6"	2	2	3	4	5	6	-
20490207	Junction (I) beam 4" x 7'-0" x 7,7 lbs/pi	-	-	-	-	-	-	1
20490218	(I) beam 4" x 10'-0" x 7,7 lbs/pi	0	1	1	1	1	2	-
20490375	(I) beam 4" x 7'-0" x 7,7 lbs/pi	1	0	0	1	1	0	-
20490274	Threaded beam clamp support	2	2	3	4	5	6	-
20490296	Beam clamp	3	3	4	5	6	7	-
20490386	Interior work support Bracket	2	2	3	4	5	6	-
20490421	Multifunctional Tube 2" x 3" x 11'-6"	2	2	3	4	5	6	-
20490814	Tightening plate for junction beam	-	-	-	-	-	-	4
25490022	Pin dia. 1/2" x 4-1/8"	2	2	3	4	5	6	-
25490055	Pin dia. 3/4" x 4-3/16"	2	2	3	4	5	6	-
25490101	Threaded U-lock 1/2-13unc 4-1/2" x 6-1/2"	2	2	3	4	5	6	-
BOA-2025	Bolt 3/4"-10unc x 2" A325 galv. assembled	3	3	4	5	6	7	8
GOU-1120	Split Pin 1/8" x 2" zinc	4	4	6	8	10	12	-



## Monorail components 500 lb (227 kg) - Bridge

Item	Description	Intermediate extension		Bridge lengths						Unit
		+2'-6" (0,75 m)	+5'-0" (1,5 m)	30' (9 m)	35' (1,6 m)	40' (12 m)	50' (15 m)	55' (16,5 m)	60' (18 m)	
20490173	Forge steel 1/4" x 2" x 6"	+1	+1	6	7	7	9	10	10	-
20490207	Junction (I) beam 4" x 7'-0" x 7,7 lbs/pi	-	-	-	-	-	-	-	-	2
20490218	(I) beam 4" x 10'-0" x 7,7 lbs/pi	*	*	3	3	4	5	5	6	-
20490375	(I) beam 4" x 7'-0" x 7,7 lbs/pi	*	*	0	1	0	0	1	0	-
20490274	Threaded beam clamp support	+1	+1	6	7	7	9	10	10	-
20490296	Beam clamp	+1	+1	8	9	9	11	12	12	-
20490386	Interior work support Bracket	+1	+1	6	7	7	9	10	10	-
20490421	Multifunctional Tube 2" x 3" x 11'-6"	+1	+1	6	7	7	9	10	10	-
20490814	Tightening plate for junction beam	-	-	-	-	-	-	-	-	4
25490022	Pin dia. 1/2" x 4-1/8"	+1	+1	6	7	7	9	10	10	-
25490055	Pin dia. 3/4" x 4-3/16"	+1	+1	6	7	7	9	10	10	-
25490101	Threaded U-lock 1/2-13unc 4-1/2" x 6-1/2"	+1	+1	6	7	7	9	10	10	-
BOA-2025	Bolt 3/4"-10unc x 2" A325 galv. assembled	+1	+1	8	9	9	11	12	12	8
GOU-1120	Split Pin 1/8" x 2" zinc	+2	+2	12	14	14	18	20	20	-

\* The number of additional beams should be determined according to the type and number of intermediate extensions sections used.

## Monorail components 1 000 lb (454 kg) - Bridge

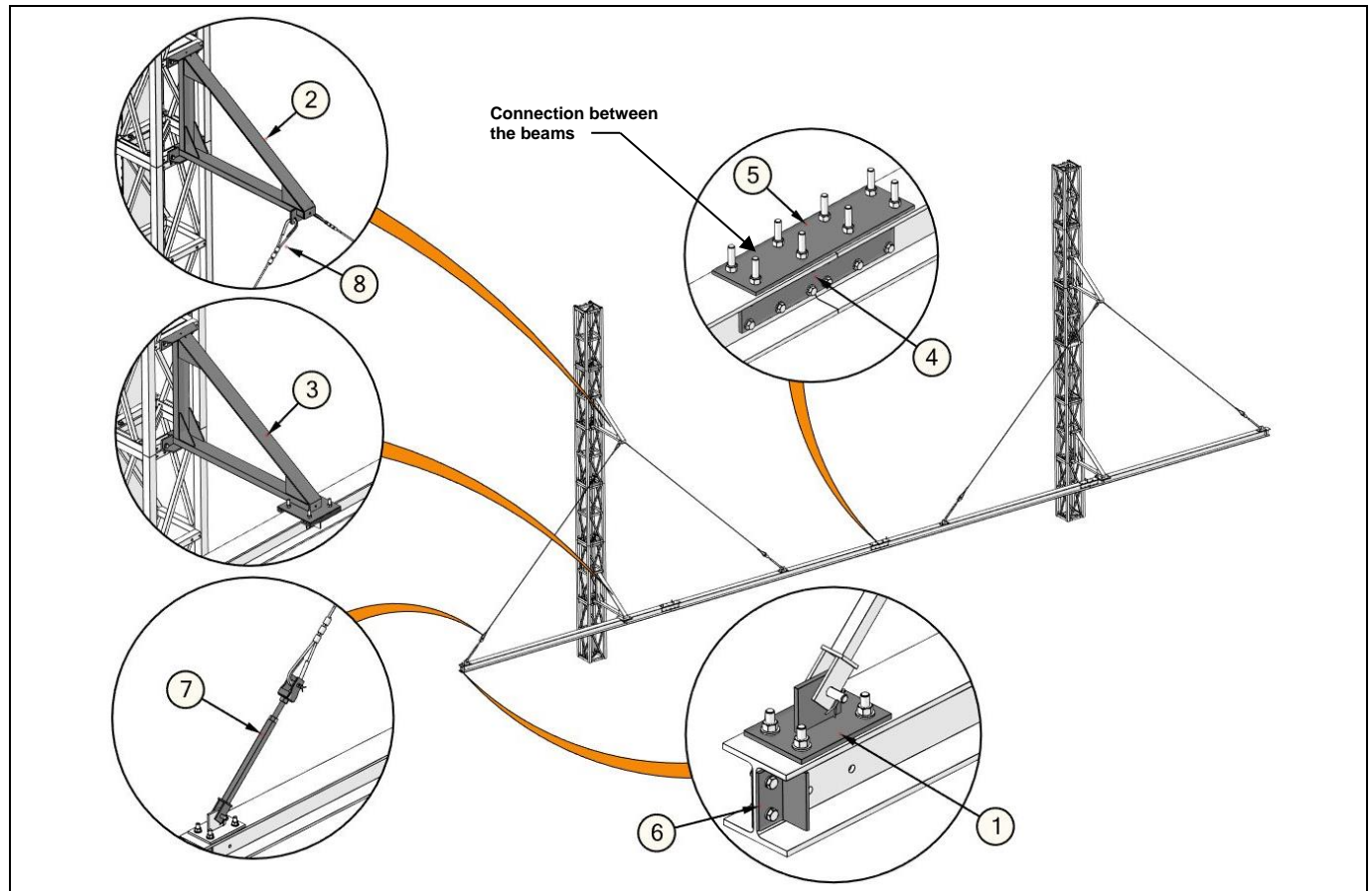
Item	Description	Intermediate extension		Bridge lengths						Unit
		+2'-6" (0,75m)	+5'-0" (1,5m)	30' (9 m)	35' (10,6 m)	40' (12 m)	50' (15 m)	55' (16,5 m)	60' (18 m)	
20490173	Forge steel 1/4" x 2" x 6"	+1	+1	11	12	13	17	18	19	-
20490207	Junction (I) beam 4" x 7'-0" x 7,7 lbs/pi	-	-	-	-	-	-	-	-	2
20490218	(I) beam 4" x 10'-0" x 7,7 lbs/pi	*	*	3	3	4	5	5	6	-
20490375	(I) beam 4" x 7'-0" x 7,7 lbs/pi	*	*	0	1	0	0	1	0	-
20490274	Threaded beam clamp support	+1	+1	11	12	13	17	18	19	-
20490296	Beam clamp	+1	+1	13	14	15	19	20	21	-
20490386	Interior work support Bracket	+1	+1	11	12	13	17	18	19	-
20490421	Multifunctional Tube 2" x 3" x 11'-6"	+1	+1	11	12	13	17	18	19	-
20490814	Tightening plate for junction beam	-	-	-	-	-	-	-	-	4
25490022	Pin dia. 1/2" x 4-1/8"	+1	+1	11	12	13	17	18	19	-
25490055	Pin dia. 3/4" x 4-3/16"	+1	+1	11	12	13	17	18	19	-
25490101	Threaded U-lock 1/2-13unc 4-1/2" x 6-1/2"	+1	+1	11	12	13	17	18	19	-
BOA-2025	Bolt 3/4"-10unc x 2" A325 galv. assembled	+1	+1	13	14	15	19	20	21	8
GOU-1120	Split Pin 1/8" x 2" zinc	+2	+2	22	24	26	34	36	38	-

\* The number of additional beams should be determined according to the type and number of intermediate extension sections used.

## Mast head monorail

**IMPORTANT!** The mast head monorail system can only be used with double-mast installations.

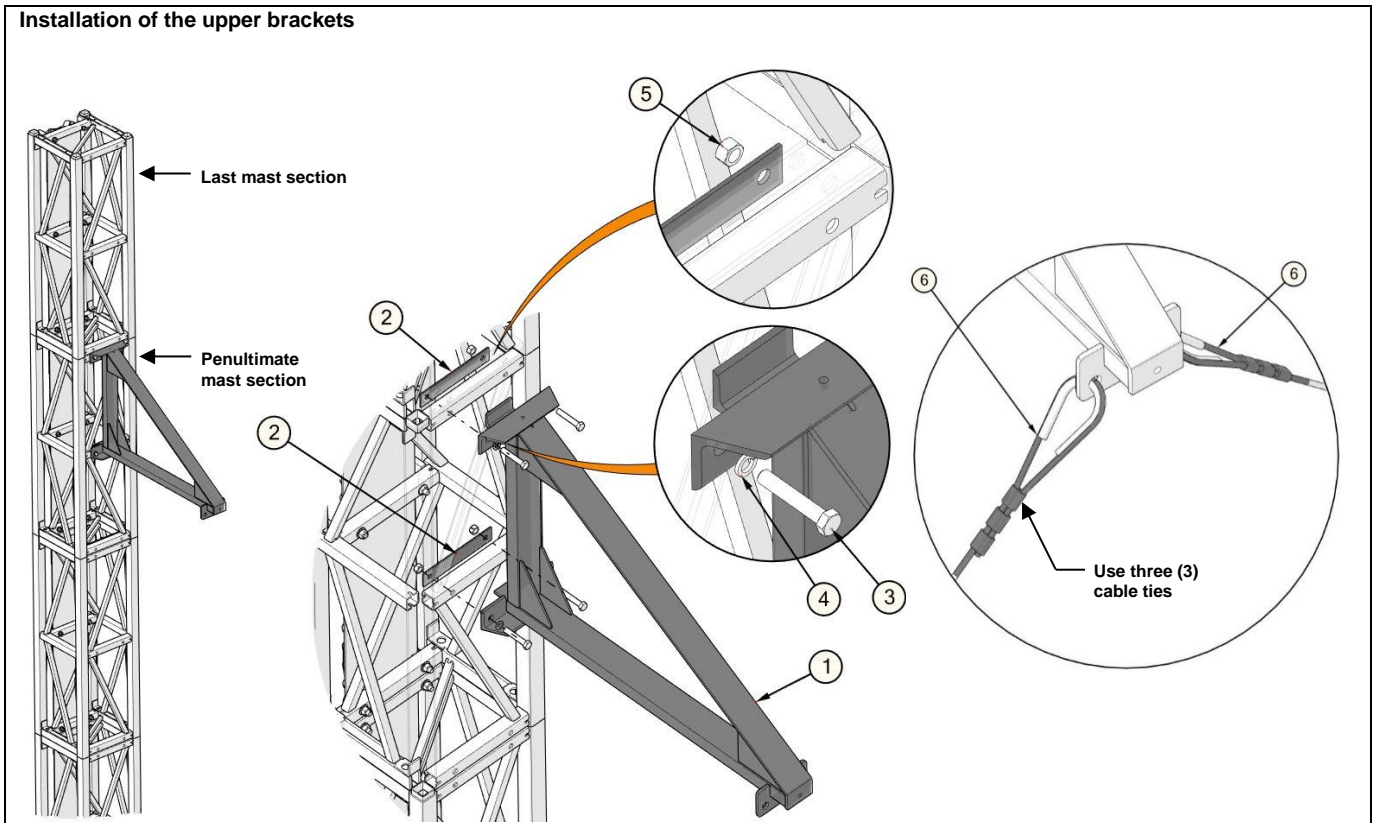
**IMPORTANT!** The final height of the masts must exceed the roof of the building by at least 30'-0" (9 m).



No	Item	Description	No	Item	Description
01	24010063	Reusable concrete anchor (offset hole)	05	20490892	Top junction plate top mast mono-rail
02	20490836	Top mast monorail cable holder	06	20491613	Limit stop for monorail (2-1/2" x 2-1/2" x 4-1/2")
03	20490847	Top mast monorail beam support bracket	07	23070125	Turnbuckle assembly (2'-0")
04	20490881	Side junction plate top mast monorail	08	XXXXXXX	Steel cable 195"

## Mast head monorail (CONTINUED)

Raise the platform until it reaches the junction between the two highest mast sections.  
 Install the top bracket on the upper or lower portion of the penultimate mast section.  
 Then install the two (2) 195" (5,0 m) steel cables in the eyelets of the top bracket, secured with three (3) cable ties.

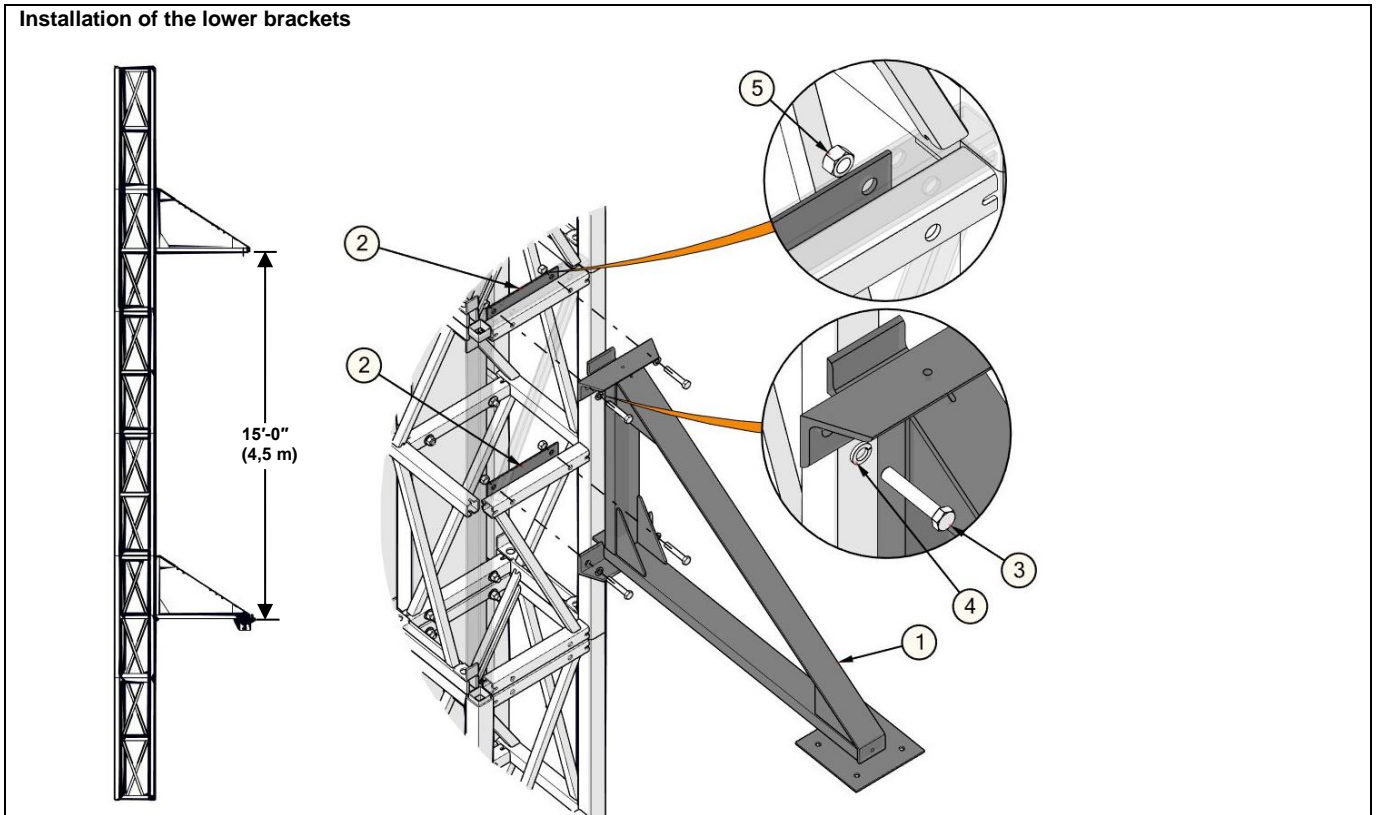


No	Item	Description	No	Item	Description
01	20490836	Top mast monorail cable holder	04	LOZ-5040	Locking washer 5/8" zinc
02	20490410	Forged steel (3/16" x 2" x 11")	05	ECZ-7065	Nut 5/8"-11unc gr5 zinc
03	BOZ-7215	Bolt 5/8"-11unc x 3-1/2" gr5 zinc	06	XXXXXX	Steel cable 195"

Figure 116 – Mast head monorail

## Mast head monorail (CONTINUED)

Lower the platform by three (3) mast sections 15'-0" (4,5 m) and install the lower brackets. Install the bracket on the upper or lower portion of the mast section.



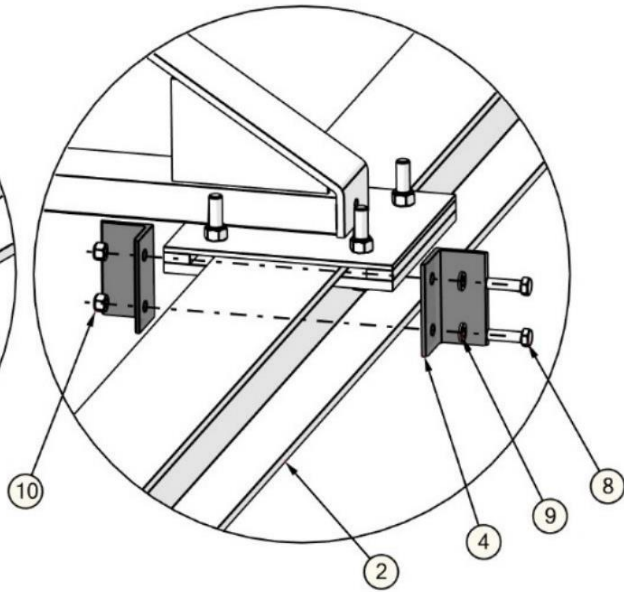
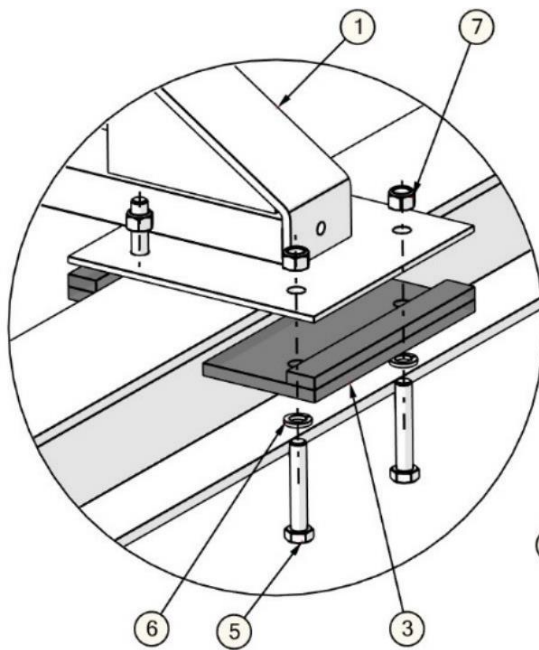
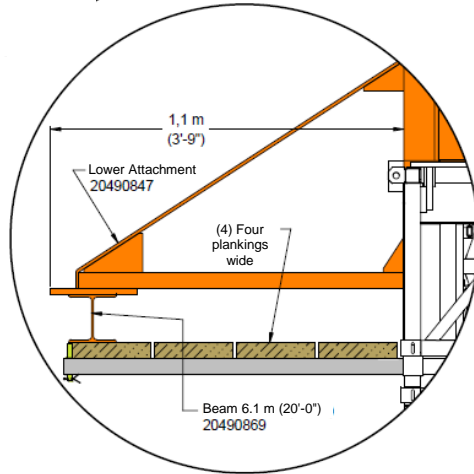
No	Item	Description	No	Item	Description
01	20490847	Top mast monorail planking support bracket	04	LOZ-5040	Locking washer 5/8" zinc
02	20490410	Forged steel 3/16" x 2" x 11"	05	ECZ-7065	Nut 5/8"-11unc gr5 zinc
03	BOZ-7215	Bolt 5/8"-11unc x 3-1/2" gr5 zinc			

Figure 117 - Mast head monorail, installation

## Mast head monorail (CONTINUED)

Extend the outriggers and install the planking for the required distance of approximately 3'-9" (1,1 m). Place the beam on the planking and raise the unit until it reaches the position of the lower attachments. Align the beams with the ends of the lower brackets.

### Installation of beams on the lower brackets

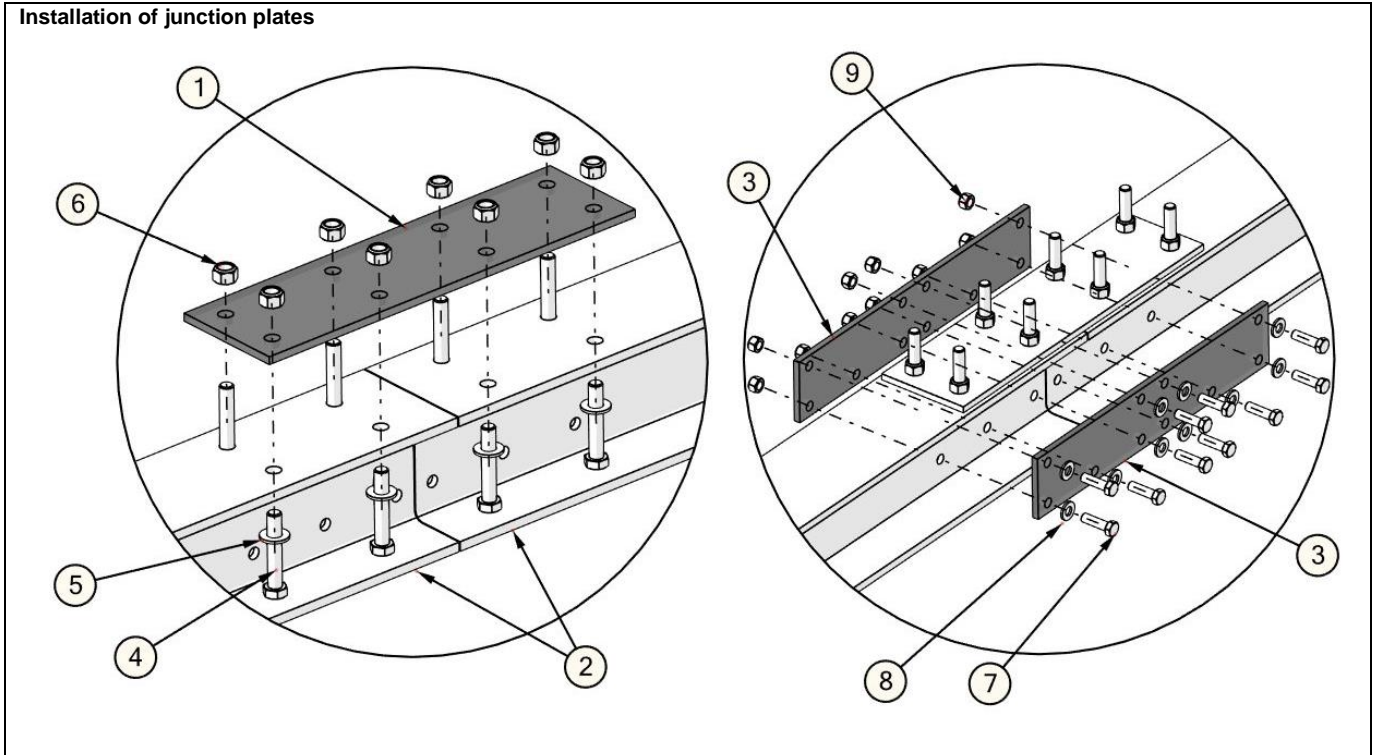


No	Item	Description	No	Item	Description
1	20490847	Top mast monorail beam support bracket	6	LOZ-5040	Locking washer 5/8" zinc
2	20490869	Monorail beam 20' top mast monorail	7	ECZ-7065	Nut 5/8"-11unc gr5 zinc
3	20490904	Bottom clamp plate for beam top mast monorail	8	BOZ-7157	Bolt 1/2"-13unc x 1-3/4" gr5 zinc
4	20491613	Limit stop for monorail (2-1/2" x 2-1/2" x 4-1/2")	9	LOZ-5030	Locking washer 1/2" zinc
5	BOZ-7215	Bolt 5/8"-11unc x 3-1/2" gr5 zinc	10	ECZ-7045	Nut 1/2"-13unc gr5 zinc

Figure 118 - Installation of a mast head monorail

## Mast head monorail (CONTINUED)

**Important!** It is prohibited to overlay a concrete anchor (24010063) over a junction plate.



No	Item	Description	No	Item	Description
1	20490892	Top junction plate top mast mono-rail	6	ECZ-7065	Nut 5/8"-11unc gr5 zinc
2	20490869	Monorail beam 20' top mast monorail	7	BOZ-7157	Bolt 1/2"-13unc x 1-3/4" gr5 zinc
3	20490881	Side junction plate top mast monorail	8	LOZ-5030	Locking washer 1/2" zinc
4	BOZ-7215	Bolt 5/8"-11unc x 3-1/2" gr5 zinc	9	ECZ-7045	Nut 1/2"-13unc gr5 zinc
5	LOZ-5040	Locking washer 5/8" zinc			

Figure 119 - Installation of a mast head monorail

### Mast head monorail (CONTINUED)

Comply with the load distribution diagram shown below.

Determine the anchor locations taking into account the following MIN and MAX dimension ranges:

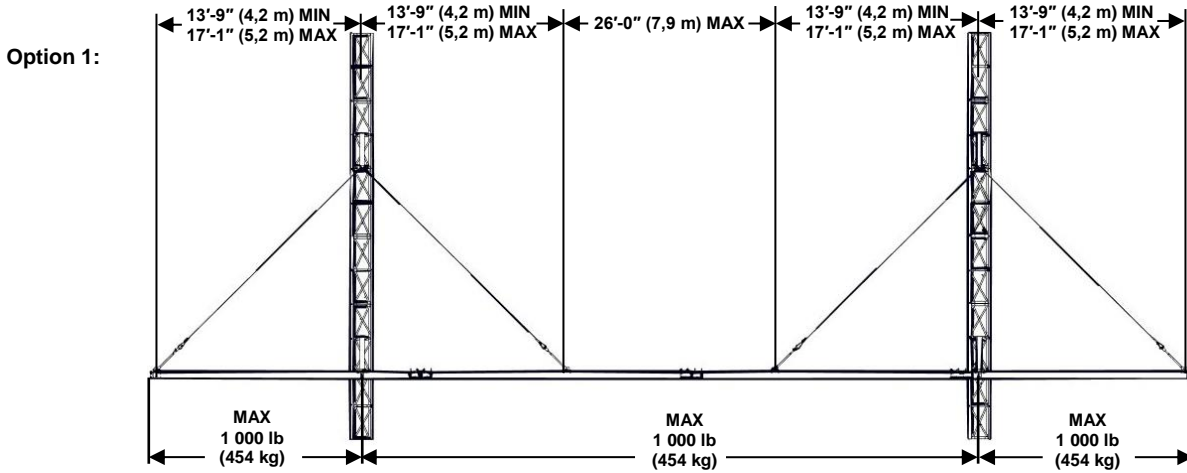


Figure 120 - Option 1, load Distribution, mast head monorail

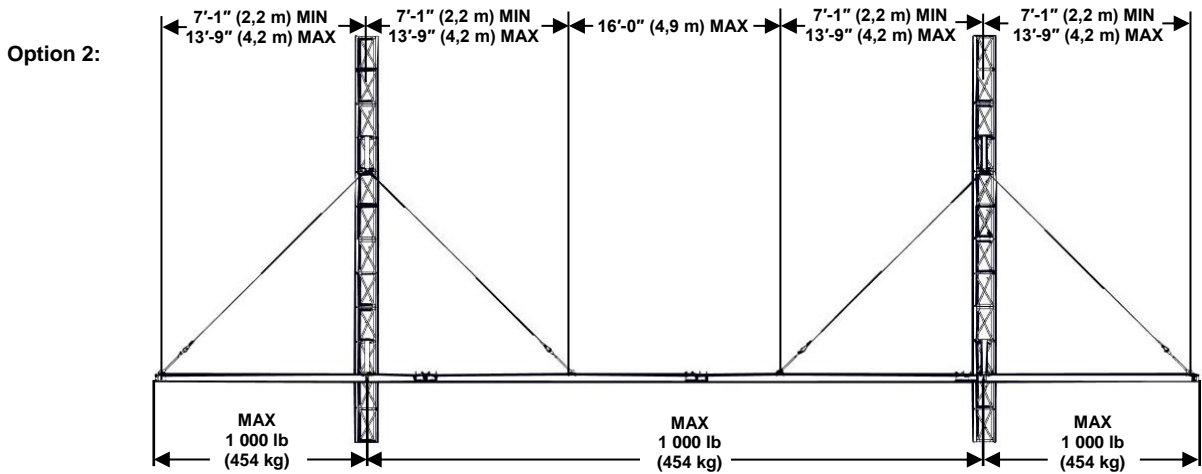


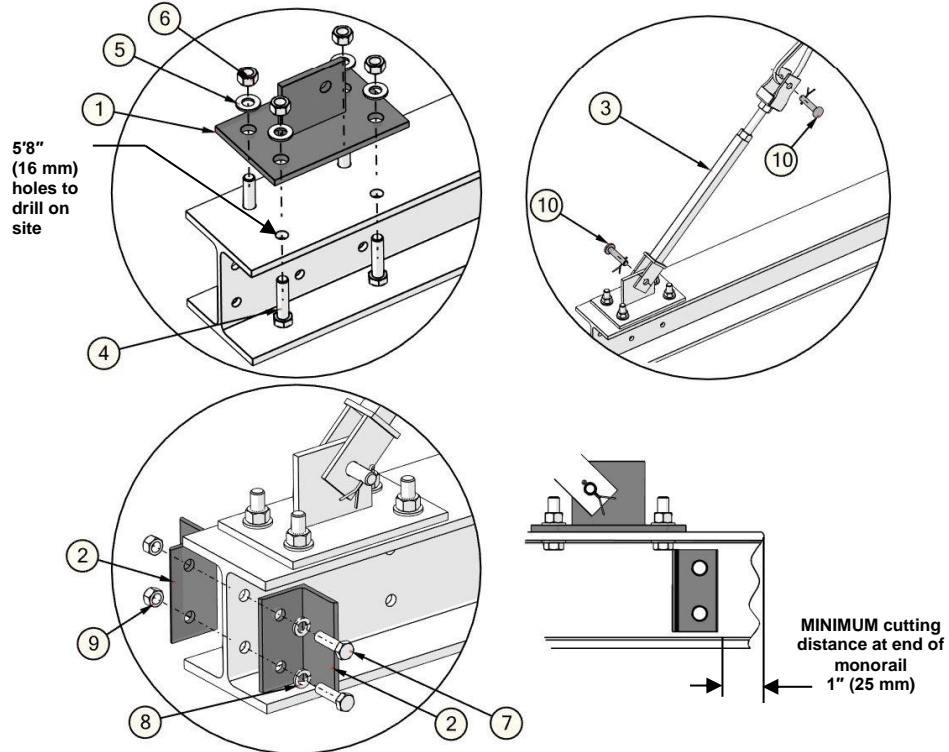
Figure 121 - Option 2, load distribution, mast head monorail

## Mast head monorail (CONTINUED)

Use the anchor plates as a drilling template to drill the beams where required. Typical 5/8" (16 mm) holes. Install the stops at each travel limit. Drill the beam if necessary.

**IMPORTANT!** The customer is responsible for having the required lifting training that complies with the current specifications, standards and regulations before using a trolley.

### Installation of turnbuckle anchors and stops



No	Item	Description	No	Item	Description
1	24010063	Reusable concrete anchor (offset hole)	6	ECZ-7065	Nut 5/8"-11unc gr5 zinc
2	20491613	Limit stop for monorail (2-1/2" x 2-1/2" x 4-1/2")	7	BOZ-7157	Bolt 1/2"-13unc x 1-3/4" gr5 zinc
3	23070125	Turnbuckle assembly 2'-0"	8	LOZ-5030	Locking washer 1/2" zinc
4	BOZ-8542	Bolt 5/8"-11unc x 2-1/2" gr8 zinc	9	ECZ-7045	Nut 1/2"-13unc gr5 zinc
5	WAZ-7041	Washer 5/8" SAE zinc	10	25490033 and GOU-1120	Pin dia. 5/8" x 3-3/16" and Split Pin 1/8" x 2" zinc

Figure 122 - Installation of a mast head monorail



## Crane FRH-2500

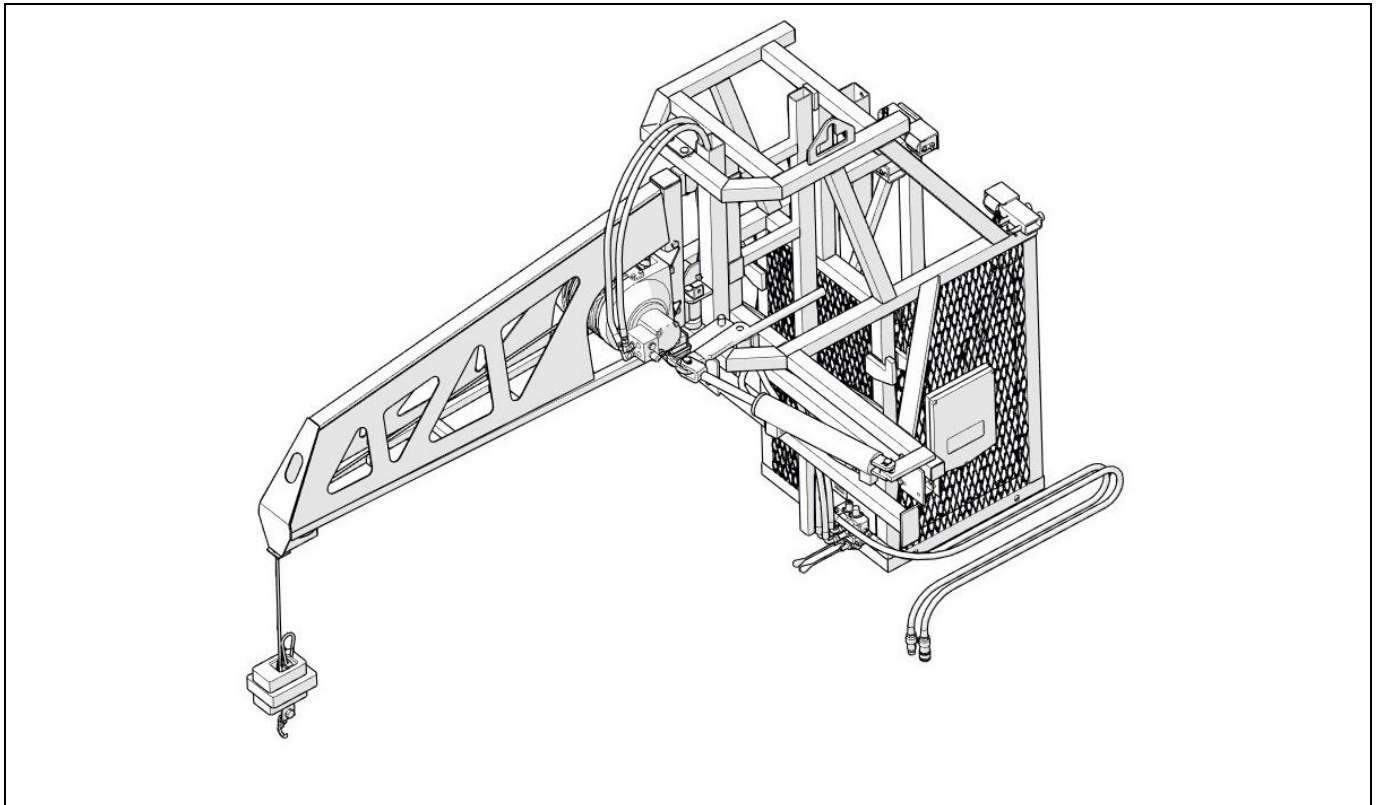
**Important!** Refer to the « WARNINGS » section and « OPERATION, USE OF THE LIFTING UNIT » for the general safety instructions and additional applicable warnings.

∞SEE WARNINGS, ON PAGE 6

∞SEE OPERATION, USE OF THE LIFTING UNIT, ON PAGE 25

### Warning:

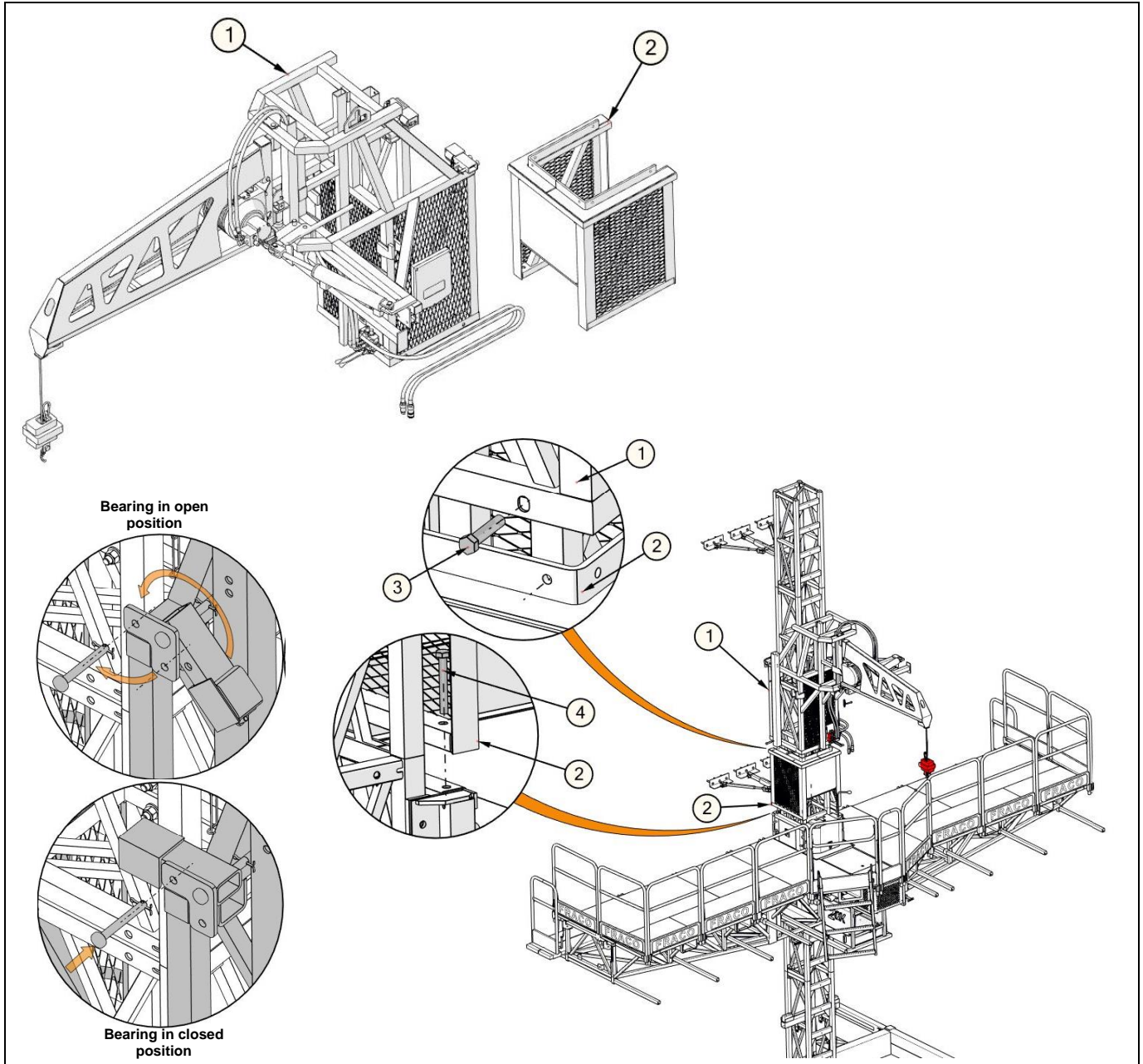
- On the ground, establish a marked safety perimeter around the lifting area and prohibit access.
- Before using the portable crane, make sure people around are aware of the potential dangers.
- This equipment must not be used for lifting or moving personnel.
- Use the controls smoothly as sudden movements may damage the winch.
- Never move or lift loads over a person.
- Do not leave loads suspended for long periods or unattended.
- Always remain at a safe distance from the load.
- Maintain a minimum of five (5) turns of cable on the drum at all times.
- The load must be lifted vertically.
- Allow the equipment to preheat before use, especially during cold temperatures.
- Wear appropriate clothing and keep hands away from moving parts when using the crane.
- Wear your safety harness, attached to a regulatory attachment point, if the guardrails are to be handled.  
∞SEE REGULATORY ATTACHMENT POINTS, ON PAGE 9
- It is **forbidden** to use a crane on a freestanding base without a wall attach system.
- It is **forbidden** to position the lift unit above the highest mast anchor device when using a portable crane



### Installation

**Important!** If the platform is installed on a ground base, the first two (2) mast anchors must first be installed. If the platform is installed on a freestanding base, at least one (1) mast anchor must be installed.

- Use the lifting hook provided for this purpose.
- Bolt the structure on top of the lifting unit.
- Once the crane is secured on the lifting unit, place the bearings in the closed position with respect to the segments of the mast sections.
- Implement the hydraulic connections to the lifting unit.



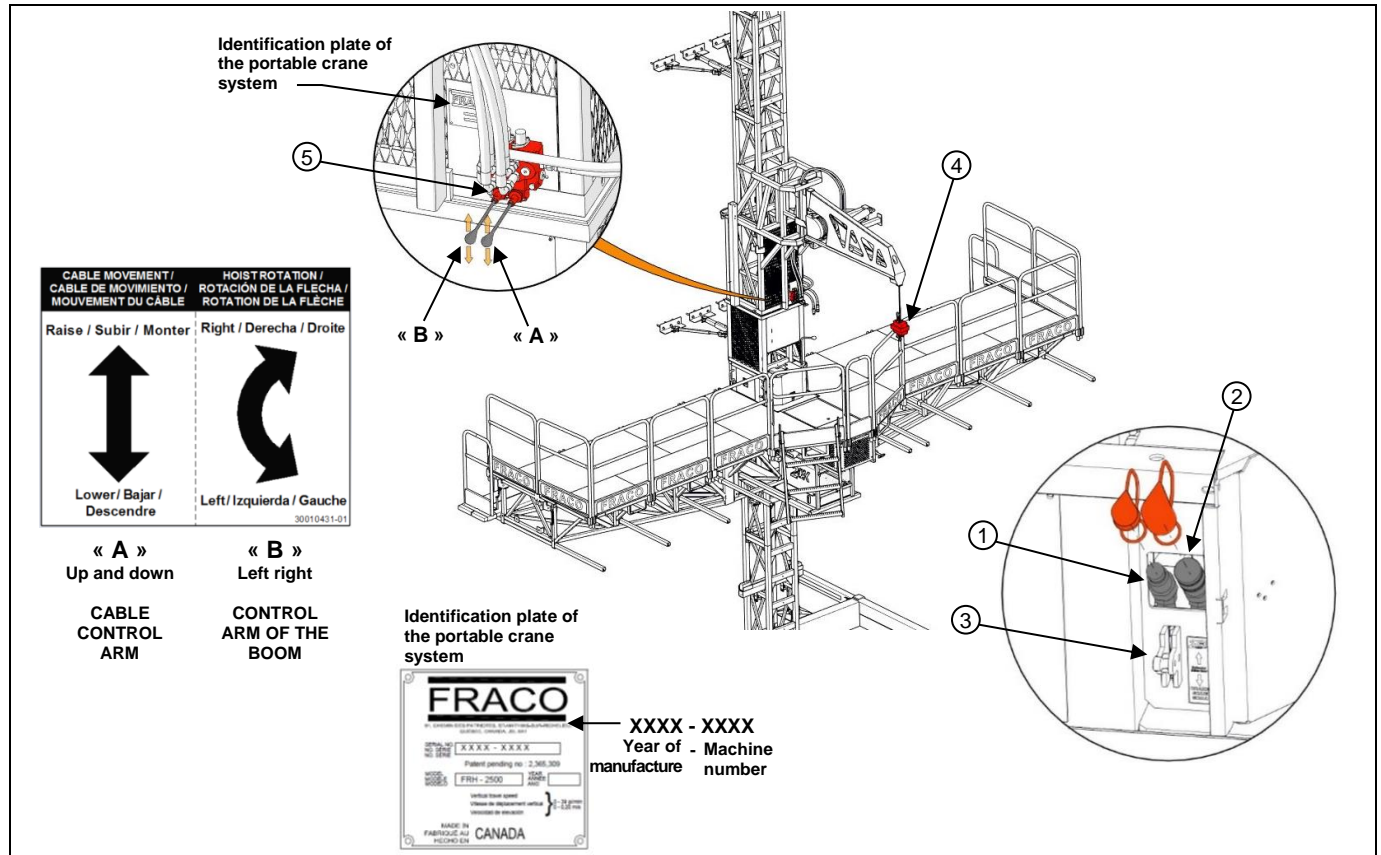
No	Item	Description	No	Item	Description
01	12490073	Mobile crane FRH-2500 for 20" x 20" mast	03	BOA-2032	Bolt 3/4"-10unc x 3-1/2" A325 galv.
02	20490779	Adapter for 20K hoist	04	BOA-2030	Bolt 3/4"-10unc x 5-1/2" A325 galv. assembled

## Operation

**Important!** Before use at the beginning of each shift, all points of the **DAILY INSPECTION GRID**, ON PAGE 155 must be checked, including a functional check. During operation, the operator must strictly follow all operating instructions.

**Important!** The portable crane operator must have the necessary skills and training to use the crane.

∞SEE OPERATION, USE OF THE LIFTING UNIT, ON PAGE 25



**Important!** Be sure to read the operating instructions for the crane on the sticker under the crane's hydraulic couplings.

**Important!** After using the crane, turn the « ACCESSORIES » switch to the « OFF » position.

If you have any questions regarding the portable crane system, please consult the documentation or contact your FRACO representative.

No	Item	Description	No	Item	Description
01	32070169	3/4" male quick coupling assembly (20K)	04	28490283	FRH2500 Weight and lifting hook
02	32070170	3/4" female quick coupling assembly (20K)	05	32060012	Distributor of the FRH2500 crane
03	28017435	Operation selector handle/shaft (20K)			



Adjustment of the hydraulic pressure and installation or replacement of the steel cable must be carried out by a person holding a **valid Level 3 card**. This person must be familiar with the instructions for use, have sufficient experience and be aware of the risks involved in the use of the platform.

Valid for the Braden Gearmatic winch (Model: B64A05 119-01)

Cable dia. 5/16 in. 1 850 PSI 2 500 lbs. max.			Cable dia. 1/4 in. 1 200 PSI 1 000 lbs. max.		
Layer	Length	Capacity	Layer	Length	Capacity
1	33'-0"	2 500 lb	1	43'-0"	1 000 lb
2	79'-0"	2 500 lb	2	100'-0"	1,000 lb
3	129'-0"	2 500 lb	3	160'-0"	1 000 lb
4	183'-0"	2 500 lb	4	224'-0"	1 000 lb
5	241'-0"	2 500 lb	5	292'-0"	1 000 lb
			6	364'-0"	1 000 lb

## Loading areas

Observe the load distributions.

∞ SEE PERMITTED CONFIGURATIONS AND LOAD DISTRIBUTION, ON PAGE 18

**Important!** Workers must wear a safety harness properly secured to an attachment point before handling the guardrails.

∞ SEE REGULATORY ATTACHMENT POINTS ON PAGE 9

Remove the guardrails to where necessary so that the equipment may pass and replace the guardrails before using the platform.

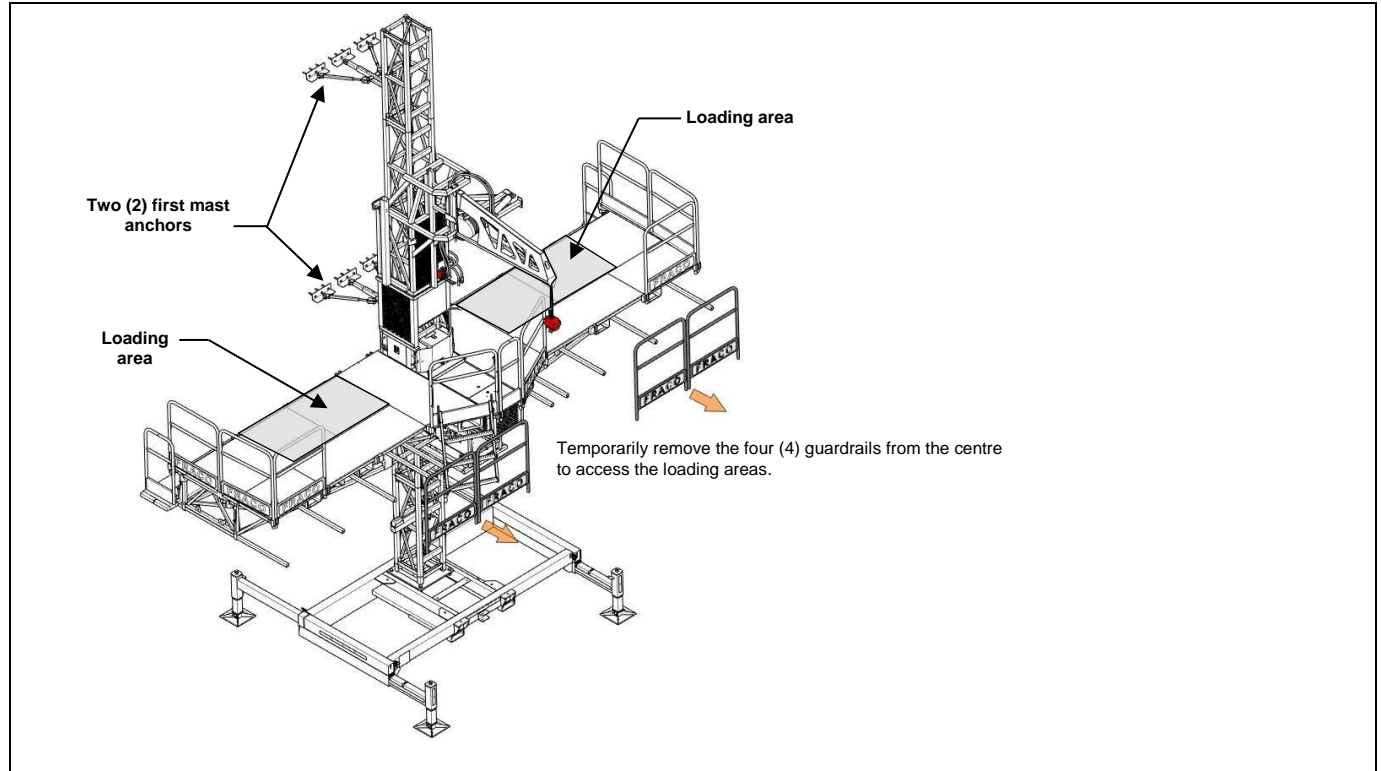


Figure 123 - FRH-2500 Crane, loading area

## Periodic maintenance

Refer to the section « PERIODIC MAINTENANCE » for the applicable points, as well as to the inspection sheet in the model-specific and serial-specific service manual.

∞ SEE PERIODIC MAINTENANCE, ON PAGE 154

∞ SEE DAILY INSPECTION GRID, ON PAGE 155

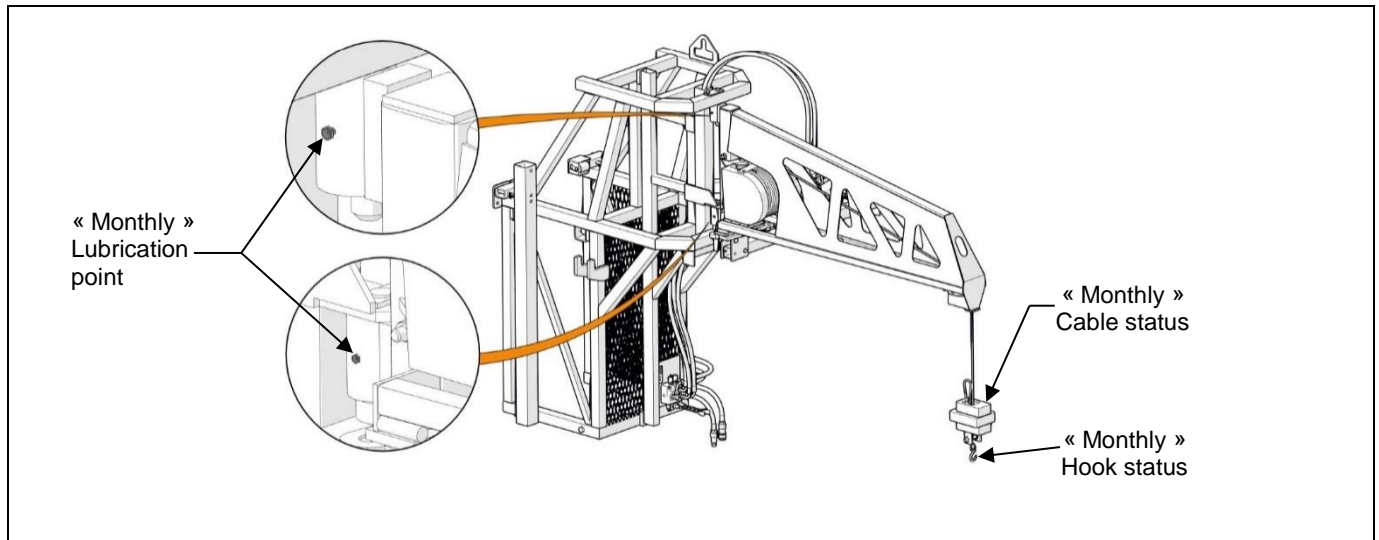


Figure 124 - FRH-2500 Crane, maintenance

## Crane FRH-4000

**Important!** Refer to the « WARNINGS » and « OPERATION, USE OF THE LIFTING unit » section for general safety instructions and additional applicable warnings.

∞SEE WARNINGS, ON PAGE 6 AND OPERATION, USE OF THE LIFTING unit, ON PAGE 25

### Warning:

- On the ground, establish a marked safety perimeter around the lifting area and prohibit access.
- Before using the portable crane, make sure people around are aware of the potential dangers.
- This equipment must not be used for lifting or moving personnel.
- Use the controls smoothly as sudden movements may damage the winch.
- Never move or lift loads over a person.
- Do not leave loads suspended for long periods or unattended.
- Always remain at a safe distance from the load.
- Maintain a minimum of five (5) turns of cable on the drum at all times.
- The load must be lifted vertically.
- Allow the equipment to preheat before use, especially during cold temperatures.
- Wear appropriate clothing and keep hands away from moving parts when using the crane.
- Wear your safety harness, attached to a regulatory attachment point, if the guardrails are to be handled.  
∞SEE REGULATORY ATTACHMENT POINTS, ON PAGE 9
- It is **forbidden** to use a crane on a freestanding base without a wall attach system.
- It is **forbidden** to position the lift unit above the highest mast anchor device when using a portable crane.

## Installation

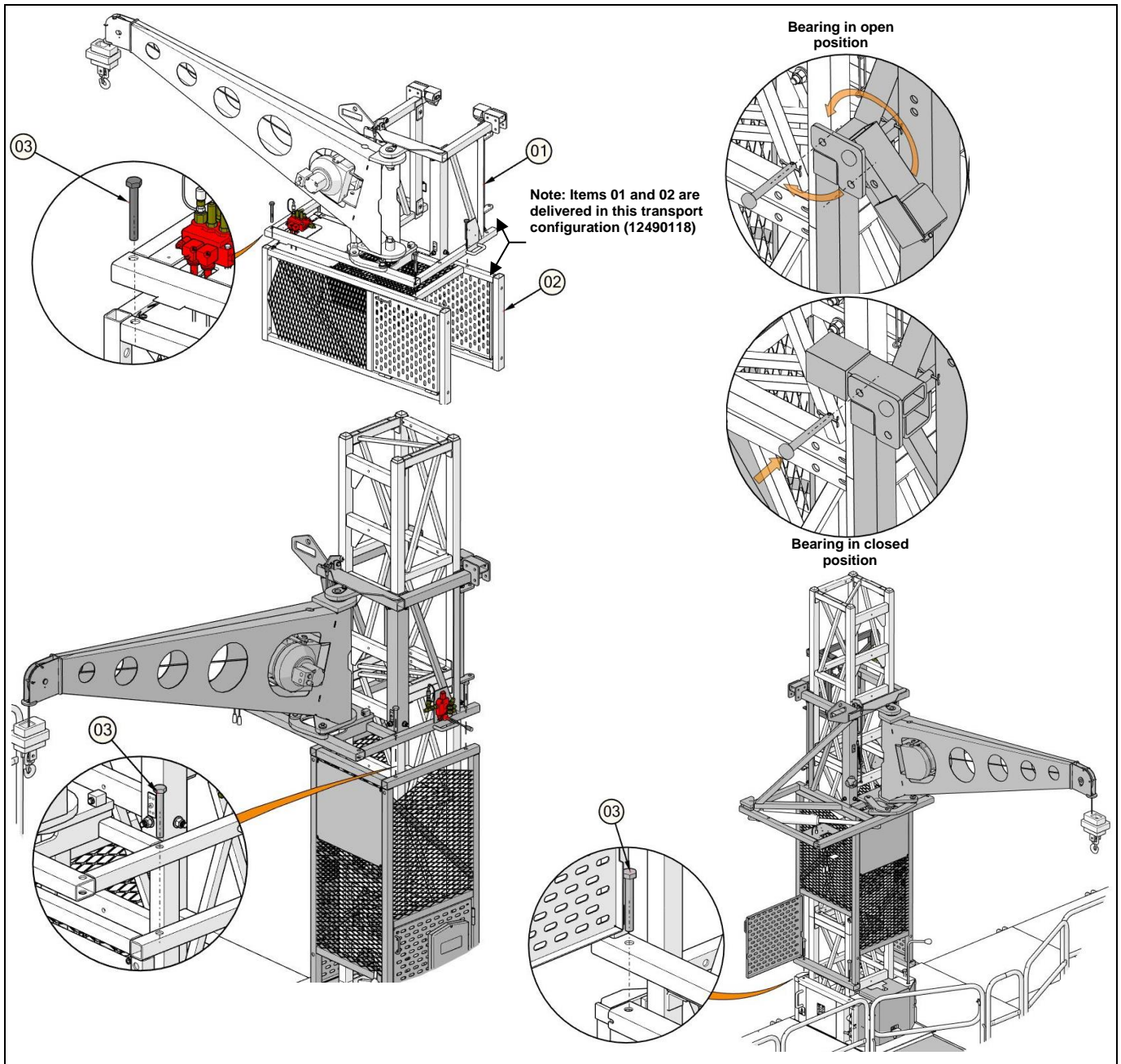
**Important!** If the platform is installed on a ground base, the first two (2) mast anchors must first be installed. If the platform is installed on a freestanding base, at least one (1) mast anchor must be installed.

Workers must wear a safety harness properly secured to an attachment point before handling the guardrails.

**Important!** The crane and extension turnbuckles must not be used simultaneously. For platforms requiring more than 13'-4" extensions, be sure to use 10'-0" tapered extensions that do not require turnbuckles.

∞SEE PERMITTED CONFIGURATIONS AND LOAD DISTRIBUTION, ON PAGE 18

- Use the lifting hook provided for this purpose.
- Bolt the structure on top of the lifting unit.
- Once the crane is secured on the lifting unit, place the bearings in the closed position with respect to the segments of the mast sections.
- Implement the hydraulic connections to the lifting unit.

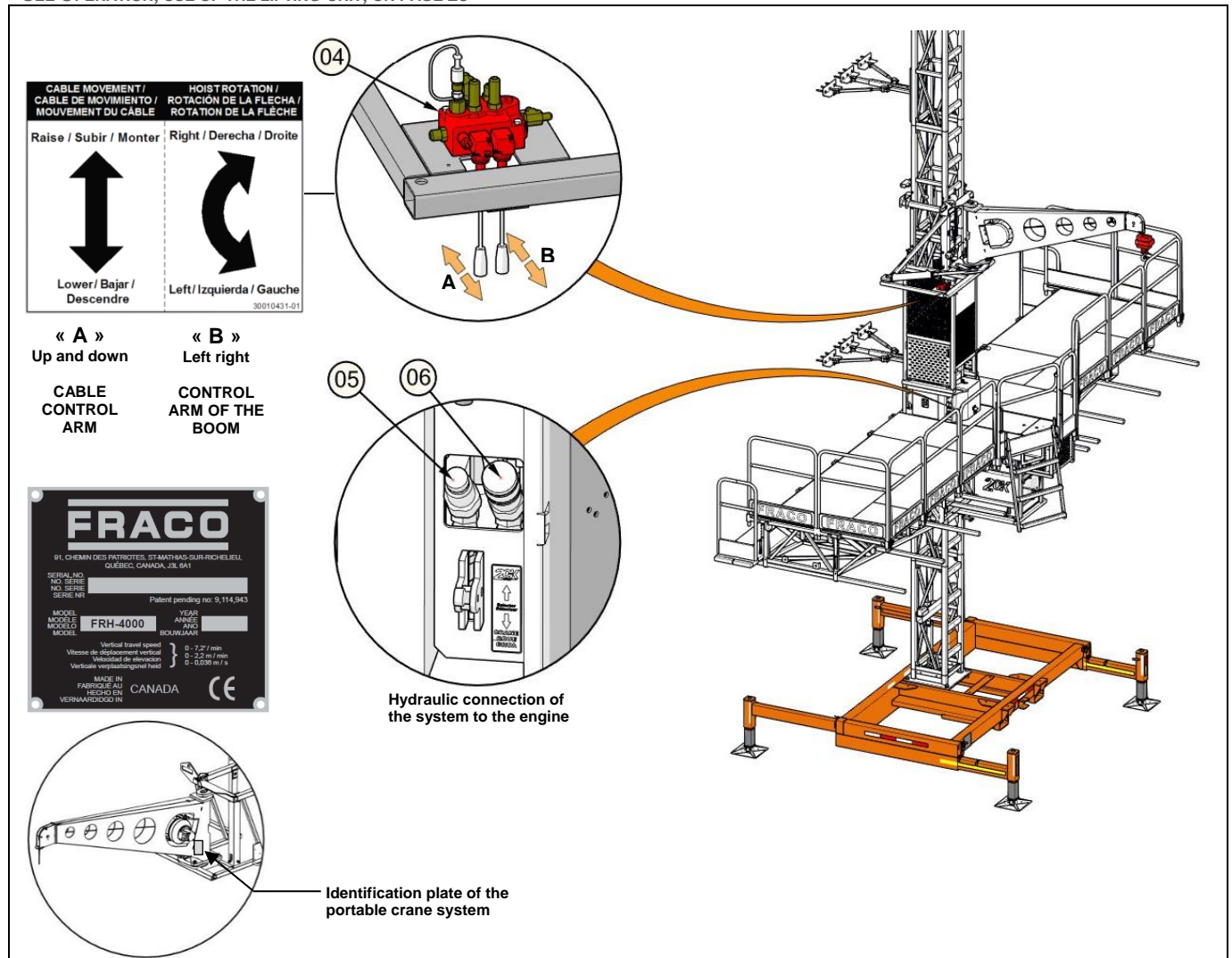


## Operation

**Important!** Before use at the beginning of each shift, all points of the **DAILY INSPECTION GRID**, ON PAGE 155 must be checked, including a functional check. During operation, the operator must strictly follow all operating instructions.

**Important!** The portable crane operator must have the necessary skills and training to use the crane.

∞ **SEE OPERATION, USE OF THE LIFTING UNIT, ON PAGE 25**



No	Item	Description	No	Item	Description
01	28494311	FRH-4000 mobile crane structure for 20" x 20" mast	05	32070169	Male quick connect 3/4" assembly (20K)
02	32060113	Protector screen assembly (FRH-4000)	06	32070170	Female quick 3/4" coupling assembly (20K)
03	BOA-2030	3/4"-10unc x 5-1/2" A325 galv. Assembled bolt	07	32060067	FRH-4000 single valve assembly
04	32060056	FRH-4000 double sections valve assembly	08	12490129	FRH-4000 self-erecting system

**Figure 125 - FRH-4000 Crane, installation**

Valid for the Braden Gearmatic winch (Model: B64A05 119-01)

Cable dia. 3/8 in. 2 850 PSI 4 000 lbs. max.			Cable dia. 5/16 in. 1 850 PSI 2 500 lbs. max.			Cable dia. 1/4 in. 1 200 PSI 1 000 lbs. max.		
Layer	Length	Capacity	Layer	Length	Capacity	Layer	Length	Capacity
1	26'-0"	4 000 lb	1	33'-0"	2 500 lb	1	43'-0"	1 000 lb
2	66'-0"	4 000 lb	2	76'-0"	2 500 lb	2	100'-0"	1 000 lb
3	109'-0"	4 000 lb	3	129'-0"	2 500 lb	3	160'-0"	1 000 lb
4	156'-0"	3 800 lb	4	183'-0"	2 500 lb	4	224'-0"	1 000 lb
			5	241'-0"	2 500 lb	5	292'-0"	1 000 lb
						6	364'-0"	1 000 lb



The adjustment of the hydraulic pressure and installation or replacement of the steel cable must be carried out by a person holding a **valid Level 3 card**. This person must be familiar with the instructions for use, have sufficient experience and be aware of the risks involved in operating the platform.



## Loading areas

Observe the load distribution.

∞ SEE PERMITTED CONFIGURATIONS AND LOAD DISTRIBUTION, ON PAGE 18

**ATTENTION:** Workers must wear a safety harness properly secured to an attachment point before handling the guardrails.

∞ SEE REGULATORY ATTACHMENT POINTS ON PAGE 9

Remove the guardrails where necessary to allow the material to pass through and reposition the guardrails before using the platform.

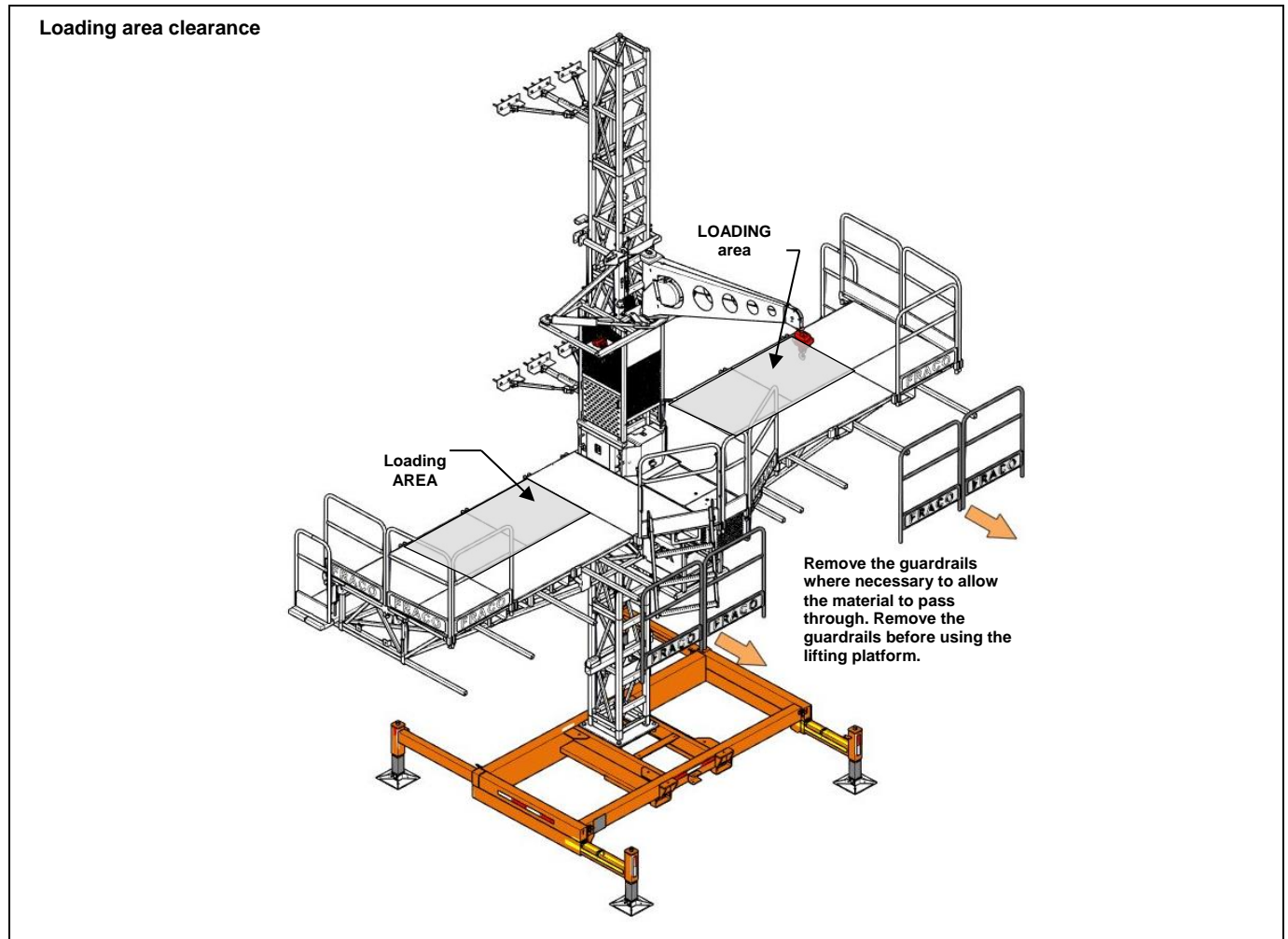


Figure 126 - FRH-4000 Crane, loading area

### Periodic maintenance

Refer to the « PERIODIC MAINTENANCE » section for the applicable points, as well as to the inspection sheet in the model-specific and serial-specific service manual.

∞ SEE PERIODIC MAINTENANCE, ON PAGE 154 AND DAILY INSPECTION GRID, ON PAGE 155

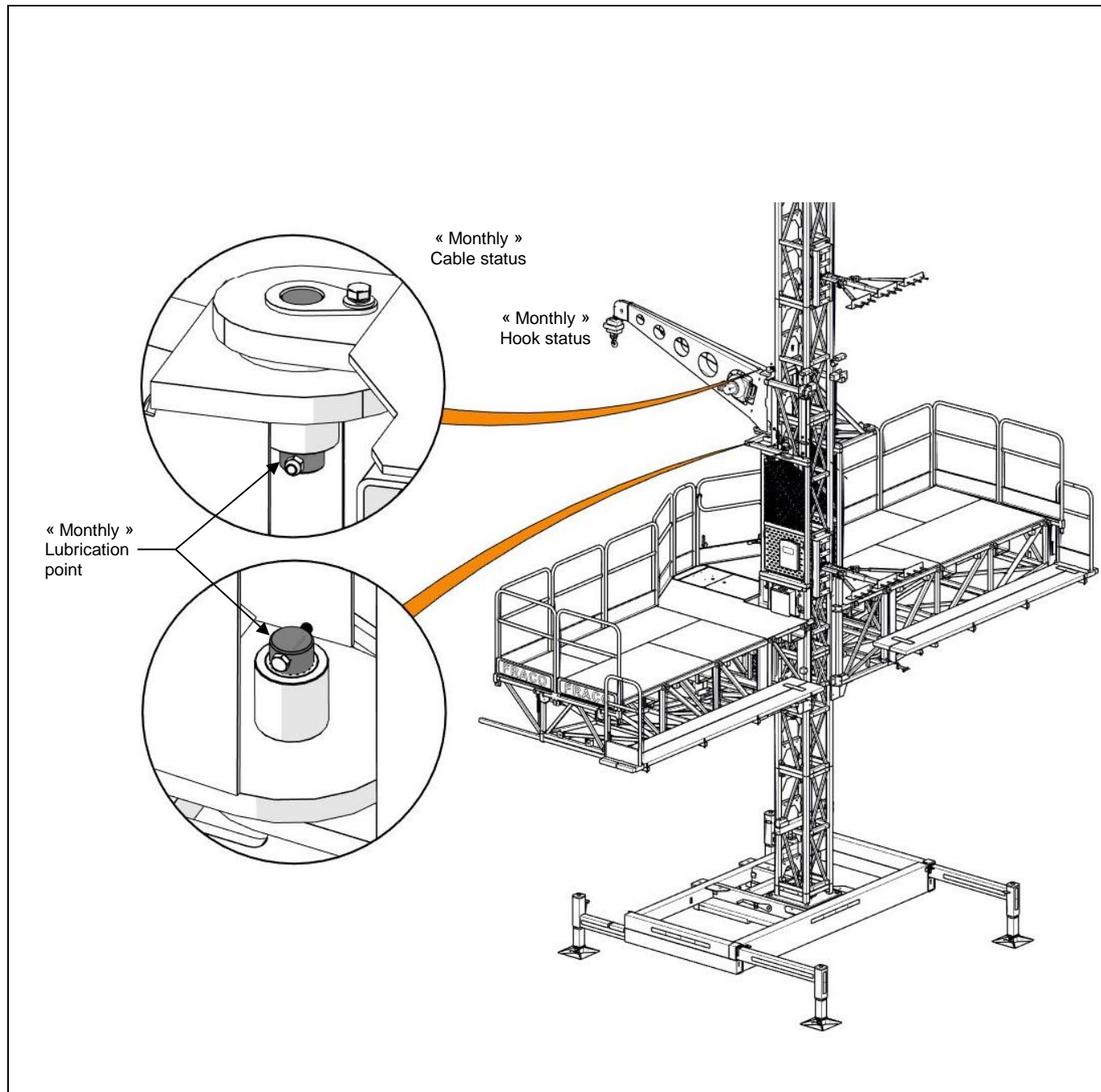
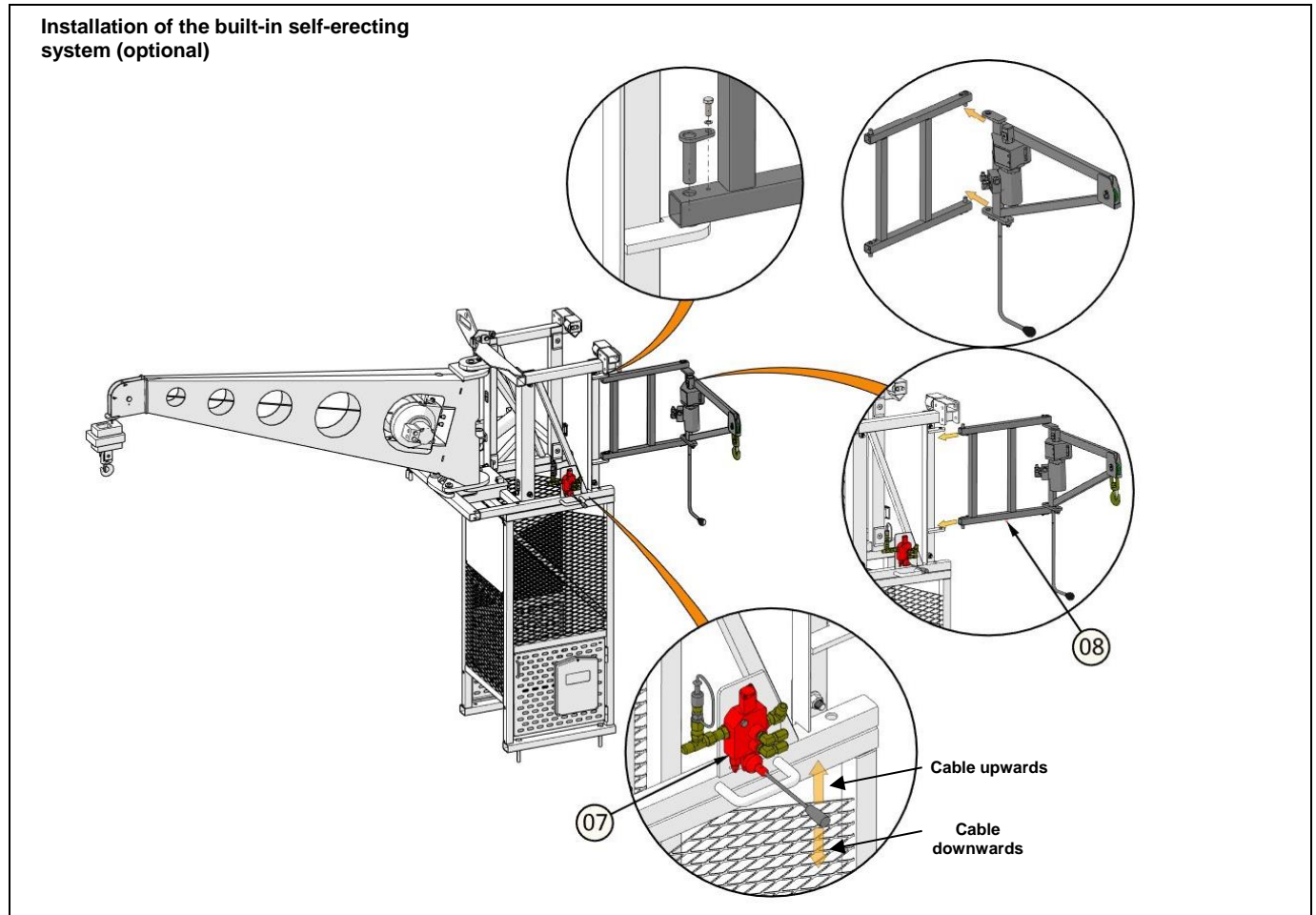


Figure 127 - FRH-4000 Crane, maintenance

## Installation of the built-in self-erecting system (optional)

Observe the load distribution.

∞ SEE PERMITTED CONFIGURATIONS AND LOAD DISTRIBUTION, ON PAGE 18



No	Item	Description	No	Item	Description
01	28494311	Mobile crane structure FRH-4000 for 20" x 20" mast	05	32070169	Male quick connect 3/4" assembly (20K)
02	32060113	Protector screen assembly FRH-4000	06	32070170	Female quick connect 3/4" assembly (20K)
03	BOA-2030	3/4"-10unc x 5-1/2" A325 galv. assembled bolt	07	32060067	Simple valve assembly FRH-4000
04	32060056	FRH-4000 double sections valve assembly	08	12490129	Self-erecting FRH-4000

## Freestanding mobile base

**Important!** These safety instructions apply specifically to this accessory and are in addition to any other safety instructions relating to the mounting, dismantling, displacement, operation and maintenance of the platform as described in the previous sections.

∞ SEE WARNINGS, ON PAGE 6

The freestanding mobile base can only be used for single-mast configuration assemblies. It is **prohibited** to use mobile bases to move a two-mast configuration assembly. It is also **prohibited** to use mobile bases with the following accessories (winter shelters, rigid roof system, FRH-2500 portable crane system or FRH-4000 and monorail system).

### Nominal power:

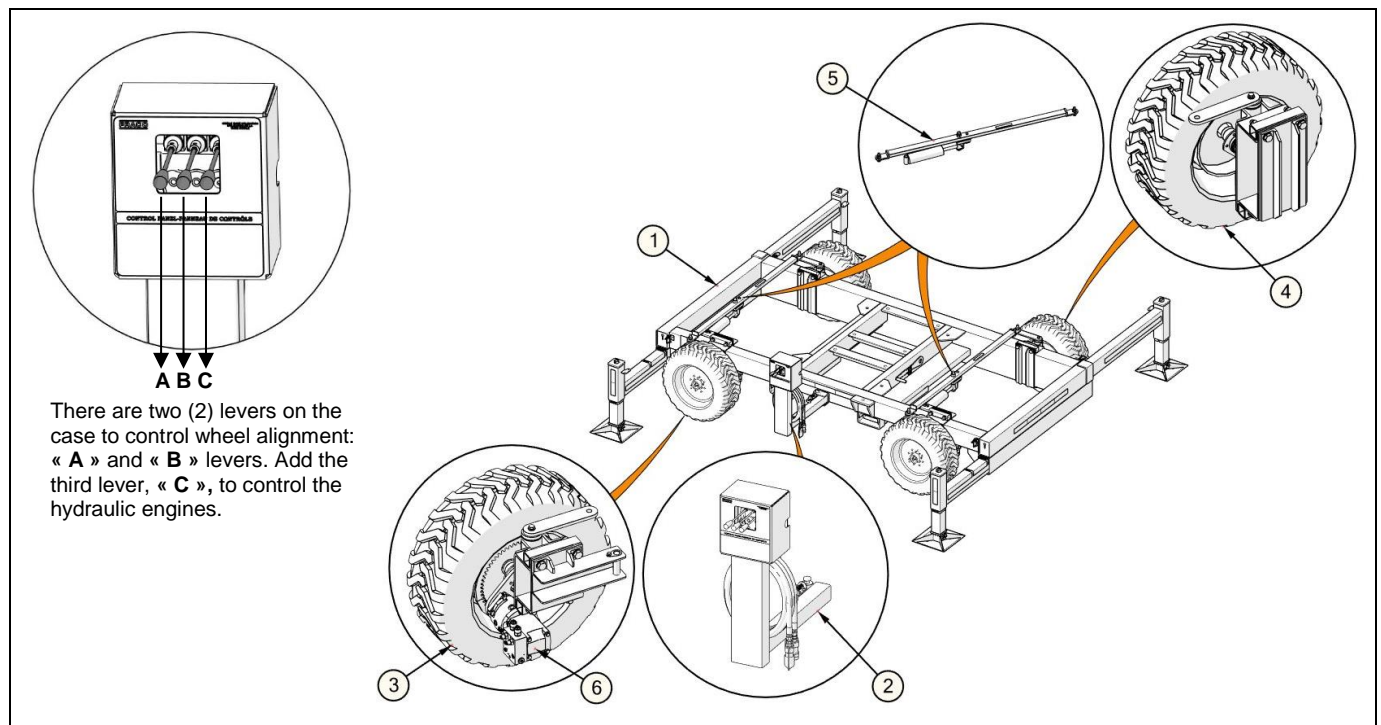
FRSM-20K (13HP/9.7kW)
FRSM-20K Ele. (20HP/14.9kW)

## Assembly



Only a certified mechanic holding a **valid Level 3 card** may perform this assembly. This person must be familiar with the operating and assembly instructions, have sufficient experience and be aware of the risks involved in using the platform.

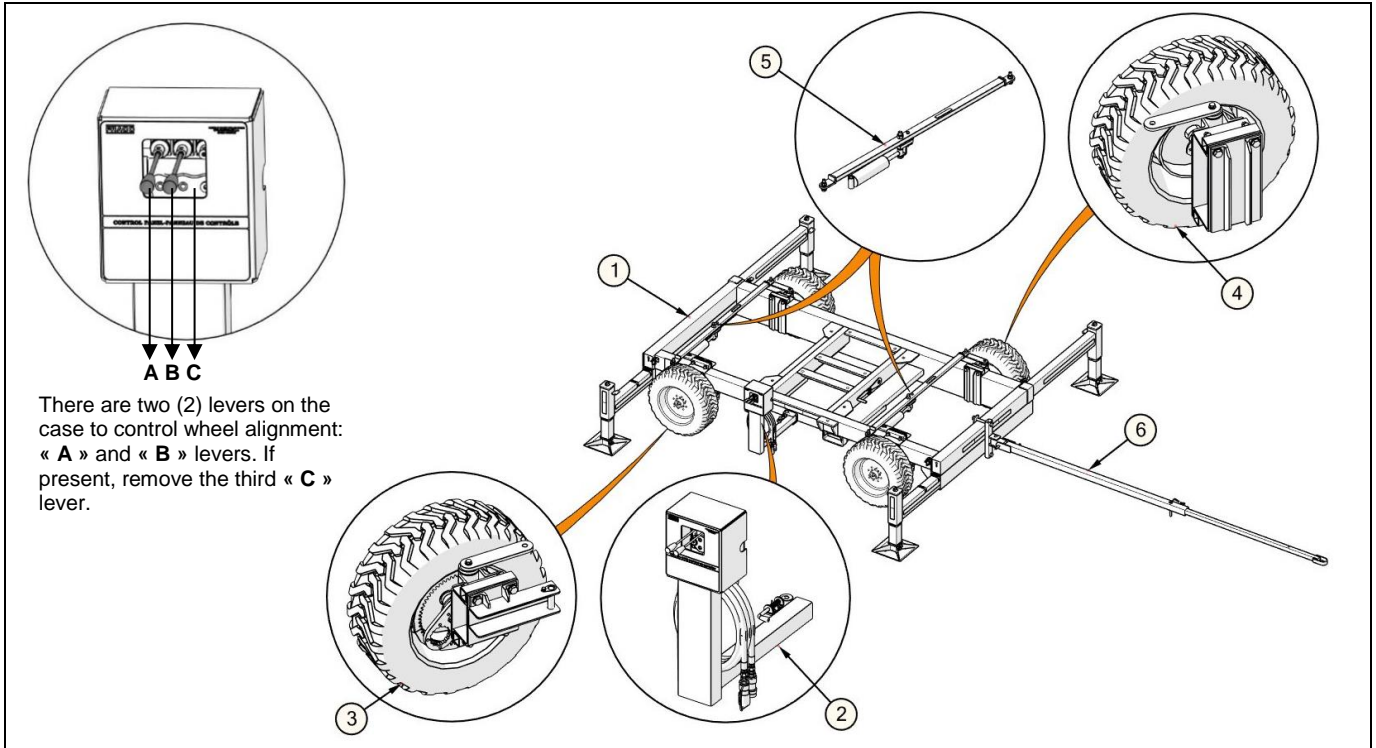
### BASE WITH ENGINE



No	Item	Description	No	Item	Description
01	14030109	Universal freestanding base	04	14490154	Non self-propelled wheel assembled (Universal mobile base)
02	14490097	Generation 4 control panel assembly for mobile base	05	14490053	Right direction tie (blue) (universal mobile base)
03	14490109	Left wheel motorized assembled (universal mobile base)	06	XXXXXXX	Wheel motor assembly

Figure 128 - Mobile base, with engine

**MOBILE BASE BY TRACTION (WITHOUT ENGINE)**

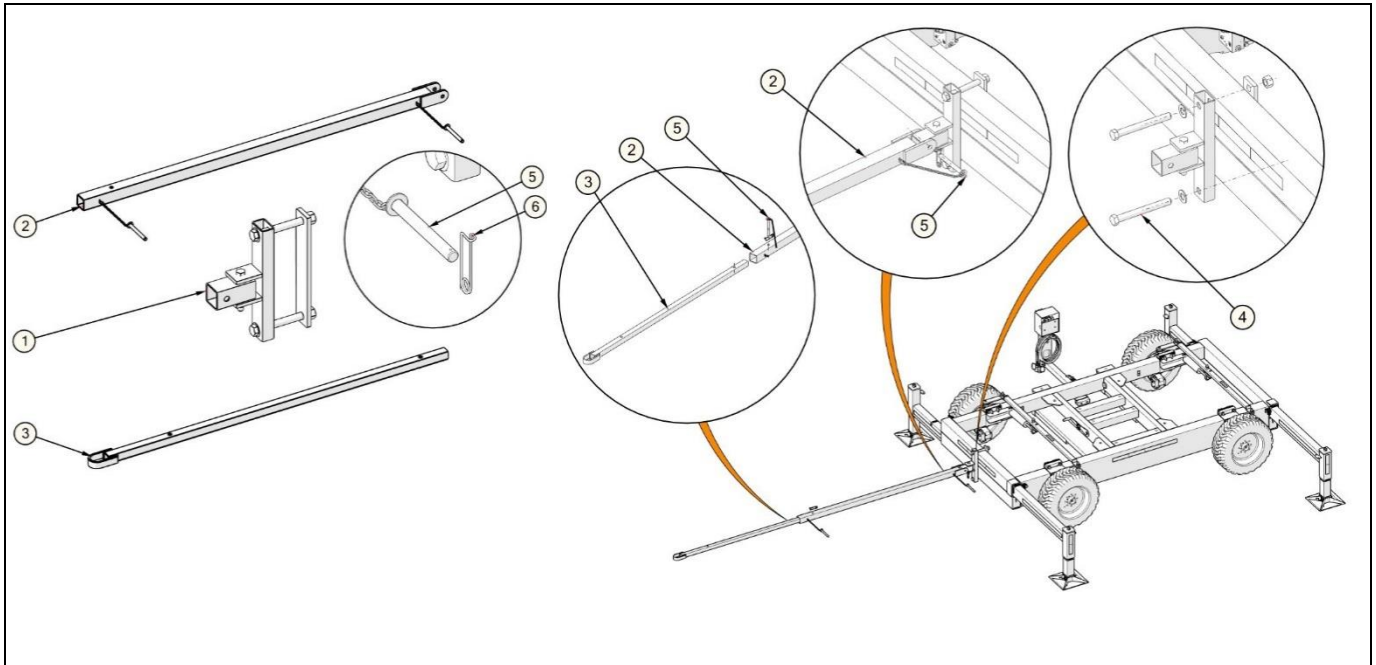


No	Item	Description	No	Item	Description
01	14030109	Universal freestanding base	04	14490154	Non self-propelled wheel assembled (Universal mobile base)
02	14490097	Generation 4 control panel assembly for mobile base	05	14490053	Right direction tie (blue) (universal mobile base)
03	14490109	Left wheel motorized assembled (universal mobile base)	06	XXXXXXX	Steering arm assembly for traction

**Figure 129 - Mobile base, traction**

*Installation of the traction arm (MOBILE BASE WITHOUT ENGINE)*

**ATTENTION:** The helm of the traction unit must be properly secured to the moving equipment.



No	Item	Description	No	Item	Description
01	14490042	Universal mobile base directionnel handle tie	04	BOA-2085	Bolt kit with washer and nut Ø 1"-8unc x 9" A325, galv.
02	20491837	Universal mobile base rudder	05	28494344	Locking shaft Ø 3/4" x 7" with 11" chain
03	20490601	Directional arm with ring (2" x 2") for mobile base	06	GOU-5020	Safety pin 1/8" x 4-1/4"

**Figure 130 - Mobile base, installation of traction arm**

**Installation of wheels**

The freestanding base must be supported by its stabilizers when installing the mobile assembly. This mobile assembly model is only used with the universal freestanding base (14030109).

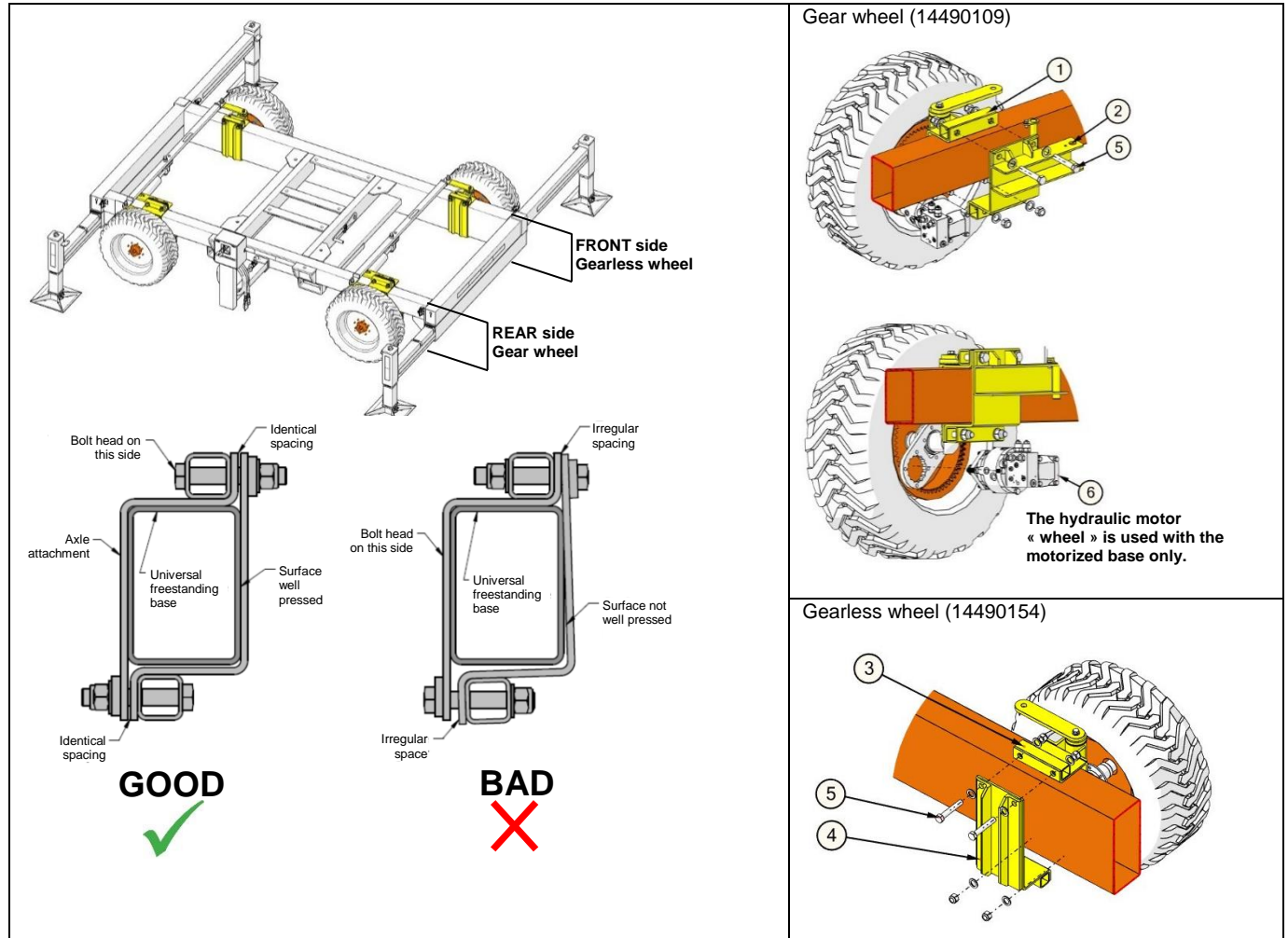
∞ SEE TECHNICAL DATA SHEET OF THE UNIVERSAL FREESTANDING BASE, ON PAGE 148

Recommended tire pressure (Check the indications on the tire sidewall)	minimum 50 psi (3,45 bar)
	maximum 70 psi (4,82 bar)

Position and bolt the gear wheels on the REAR side of the base and the gearless wheels on the FRONT side (wall side).

**Important!** The movable axle pivot must be on top. Pay attention to the bolt's insertion direction.

Ensure there is an identical space between the top and bottom plates. The surface of the fastener must be properly supported on the sides of the tubes of the freestanding base.

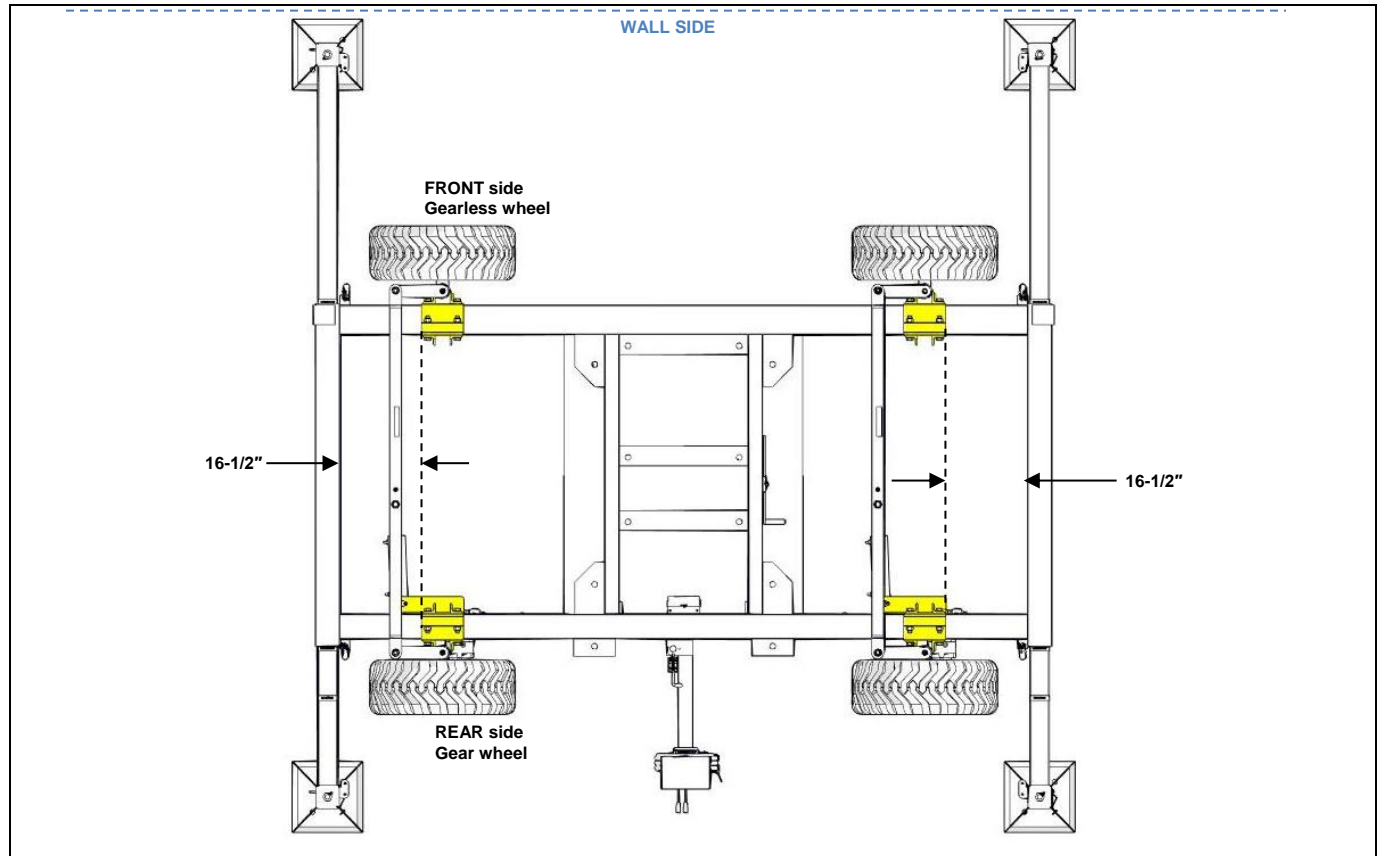


No	Item	Description	No	Item	Description
01	28496368	Attachment for left axle (mobile base)	04	28496379	Attachment for right inner axle (mobile base)
02	28496380	Attachment for left inner axle (mobile base)	05	BOZ-7245	Bolt 3/4"-10unc x 4-1/2" gr5 zinc
03	28496391	Attachment for right axle (mobile base)	06	HYE-3597	Assembled hydraulic motor 400 cc - with brake + counterbalance valve

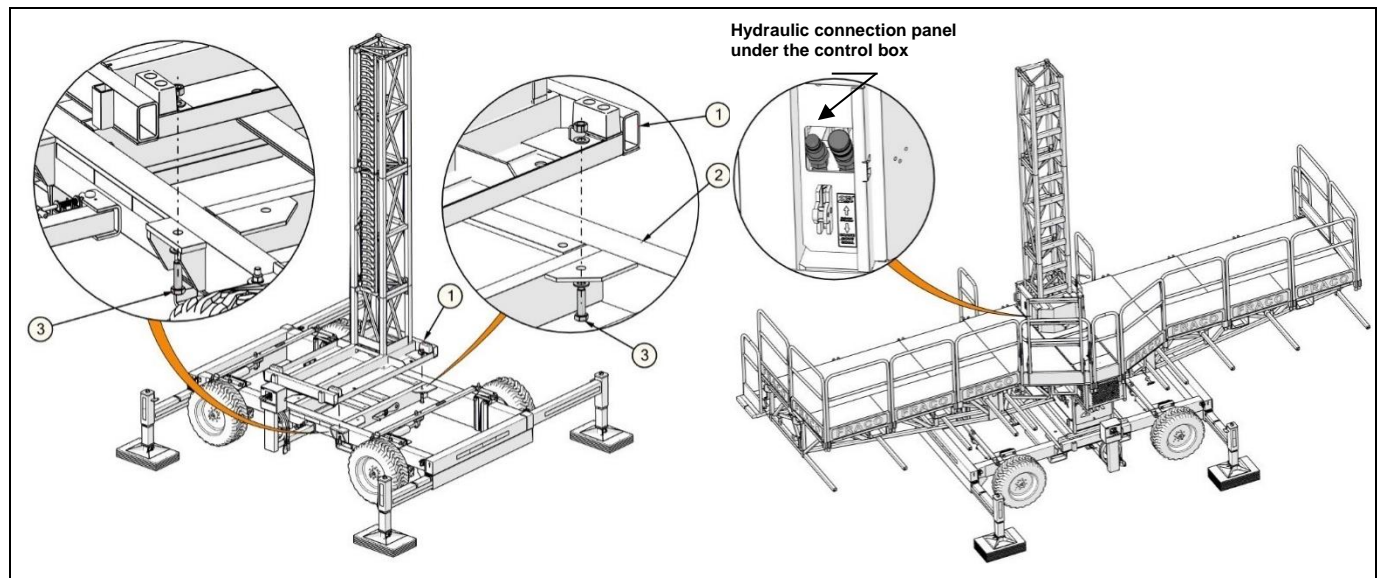
Figure 131 - Mobile base, installation of wheels

**Installation of wheels (CONTINUED)**

Check the installation spacing of the wheels with respect to the inside of the bracket support beams.



**Installation of the base and lifting unit**



No	Item	Description	No	Item	Description
01	14030019	Ground base for 20" x 20" mast (3'-6" x 6'-0")	03	BOA-2072	Bolt 1"-8unc x 3-1/2" A325 galv. assembled
02	14030109	Universal freestanding base			

Figure 132 - Mobile base, unit installation



## Mobile base use



The operator must hold a **valid Level 1 card**. This person must be familiar with the instructions for use, have sufficient experience and be aware of the risks involved in operating the platform.

**Important!** Before use at the beginning of each shift, all points of the « **DAILY INSPECTION GRID** » must be checked, including a functional check. During operation, the operator must strictly follow all operating instructions.

∞ SEE DAILY INSPECTION GRID, ON PAGE 155

Lower the platform to its lowest level (lifting unit in contact with the base).

Remove the mast sections and bridge and/or extension sections.

The movement configuration allows a maximum of 45'-0" (13,7 m) of mast sections and 20'-0" (6,1 m) of extension section on either side of the lifting unit.

Remove all loads on the platform before using the assembled mobile base.

Make sure all components are properly secured.

Check the clearance of all parts of the platform and base before starting any movement (e.g. balconies, electrical wiring, etc.).

Implement the hydraulic connections to the lifting unit.

Start the lifting unit and set the switch to « **ACCESSORIES** »

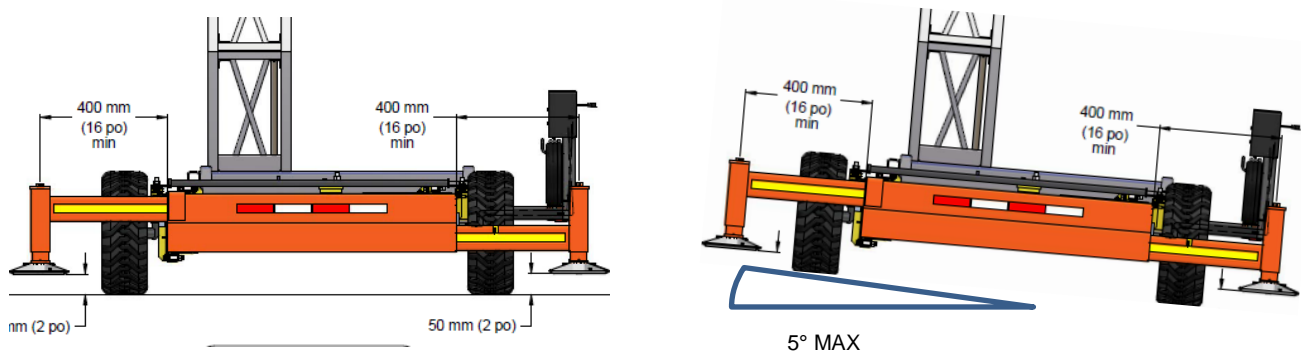
∞ SEE OPERATION, USE OF THE LIFTING UNIT, ON PAGE 25



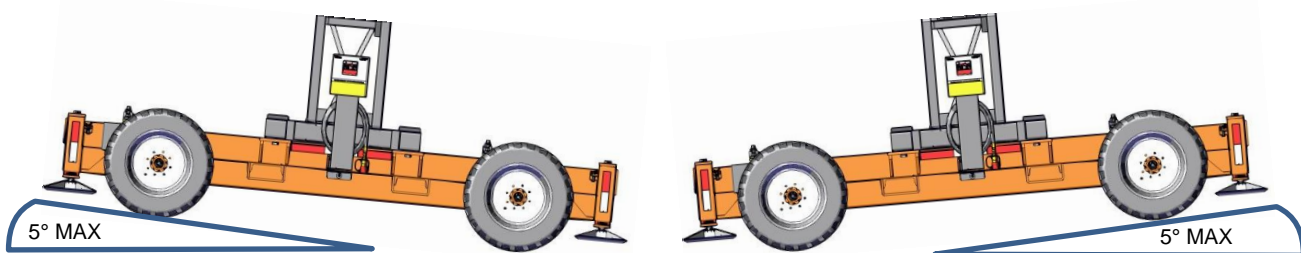
**ATTENTION:** When moving, the stabilizers on the movable base must be at least 16" (400 mm) extended and the pads must be at 2" (50 mm) from the ground.

Do not exceed a speed of 3,1 m/h (5 km/h) when moving the base.

Do not exceed an inclination of 5° (the ground must be relatively straight and without sudden level changes). A spirit level on the base indicates the inclination level



Use the control box levers to steer the wheels when moving.



**Control box**

Lever n°1 is used to orient the **Left** wheels, while Lever n°2 is used to orient the Right wheels.  
 Lever n°3 is used to actuate the hydraulic motor of the rear wheels. The lever is removed if not necessary.  
 The minimum turning radius is 7'-0" (2,1 m).

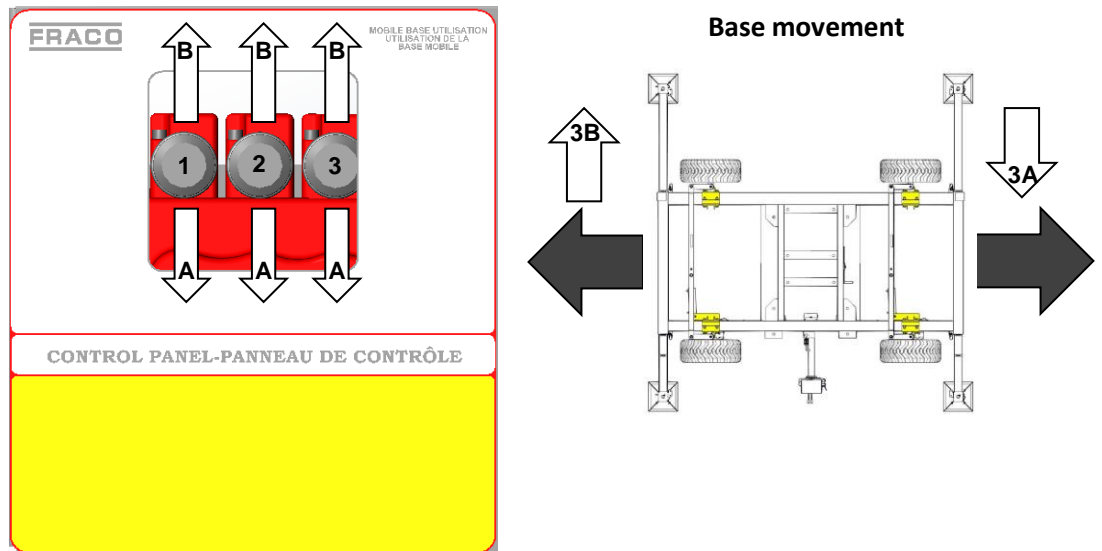
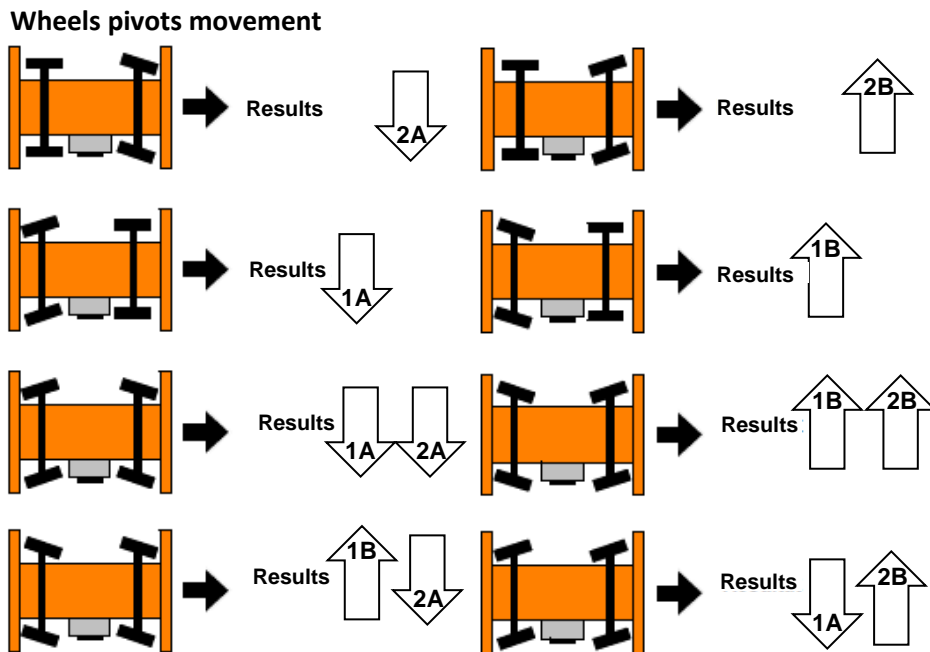


Figure 133 - Mobile base operating sticker (30060290)



**Warning:** When movement is complete and BEFORE using the platform, turn the selector switch back to the « OFF » position and disconnect the hydraulic connections to the lifting unit.

∞ SEE OPERATION, USE OF THE LIFTING UNIT, ON PAGE 25

## Index

### Technical data sheets

#### Lifting unit technical data sheet

Table 12 - Technical data sheet, lifting unit

	Lifting unit (10060018), (10060029 CE)	Imperial	Metric
<b>A</b>	Length (see <a href="#">Figure 134</a> )	7'-6"	2,3 m
<b>B</b>	Width (see <a href="#">Figure 134</a> )	7'-6 1/4"	2,3 m
<b>C</b>	Height (see <a href="#">Figure 134</a> )	5'-4"	1,6 m
	Mass (gas lifting unit + ground base + first mast section)	4 200 lb	1 905 kg
	Mass (gasoline only lifting unit)	3 205 lb	1 455 kg
	Lifting capacity	10 000 lb	4 536 kg
	Travel Speed (Gas)	0 – 7,2 fpm	0 – 2,2 m/min

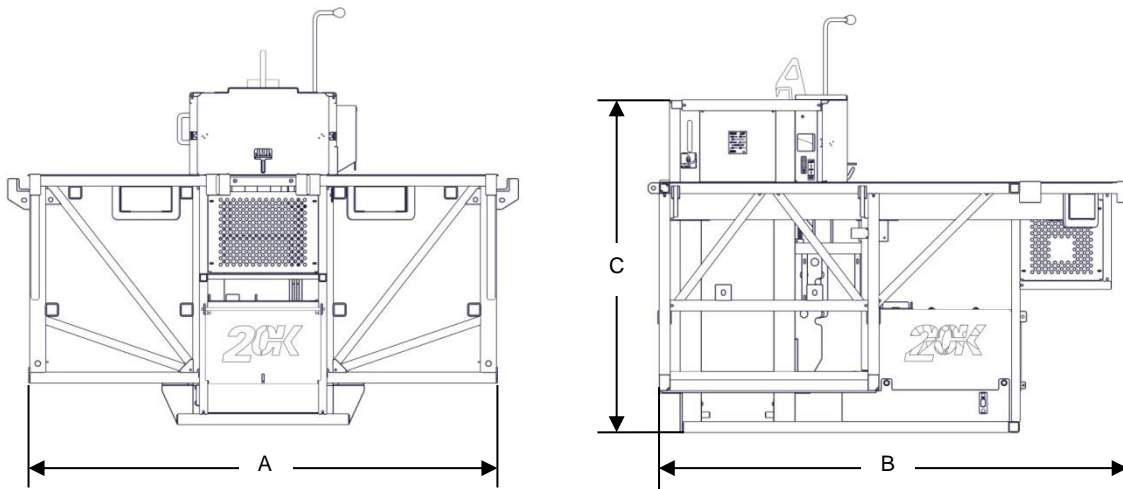


Figure 134 - Lifting unit dimensions

## Technical data sheet of the ground base

Table 13 - Technical data sheet ground base

	Ground base (14030019)	Imperial	Metric
<b>D</b>	Length (see <a href="#">Figure 135</a> )	3'-6"	1,1 m
<b>E</b>	Width (see <a href="#">Figure 135</a> )	6'-1 7/8"	1,9 m
<b>F</b>	Height (see <a href="#">Figure 135</a> )	2'-10 1/4"	869 mm
	Mass (Ground base only)	740 lb	335 kg
	Mass (gas lifting unit + ground base + first mast section)	4 200 lb	1 905 kg

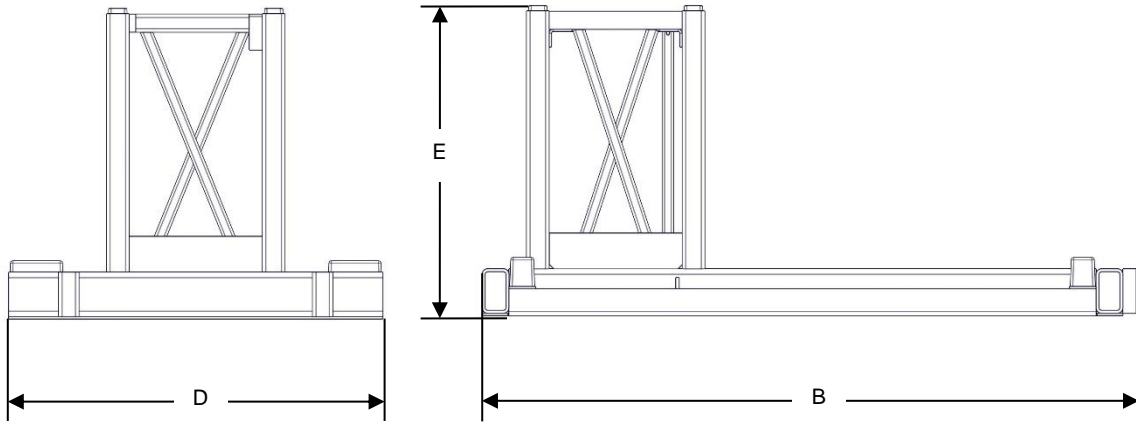


Figure 135 - Ground base dimensions

## Technical data sheet of the universal freestanding base

Table 14 - Technical data sheet universal freestanding base

	Universal freestanding base (14030109)	Imperial	Metric
<b>G</b>	Length (see <a href="#">Figure 137</a> )	12'-5"	3,78 m
<b>H</b>	*Maximum width (see <a href="#">Figure 137</a> )*	12'-10 3/4"	3,93 m
<b>I</b>	*Minimum width (see <a href="#">Figure 137</a> )*	8'-1"	2,46 m
<b>J</b>	Maximum height (see <a href="#">Figure 137</a> )*	2'-5 5/8"	752 mm
	Mass (freestanding base only)	2 255 lb	1 025 kg
	Mass (lifting unit + ground base + freestanding base + first mast section)	6 455 lb	2 930 kg
<p>*The specified widths must take into account the limits imposed by the <b>MINIMUM</b> and <b>MAXIMUM</b> stickers mentioned in the notes below.            Note: The permissible slope of the chassis is 0,5° <b>MAXIMUM</b>.            Note: The « <b>MINIMUM</b> » stickers (see <a href="#">Figure 136</a>) indicate the maximum opening of the outriggers.            Note: The « <b>MAXIMUM</b> » stickers (see <a href="#">Figure 136</a>) indicate the maximum opening of the outriggers.</p>			

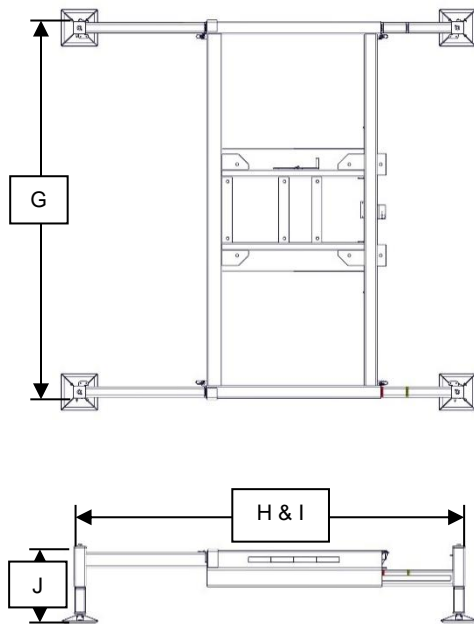


Figure 137 - Universal freestanding base dimensions

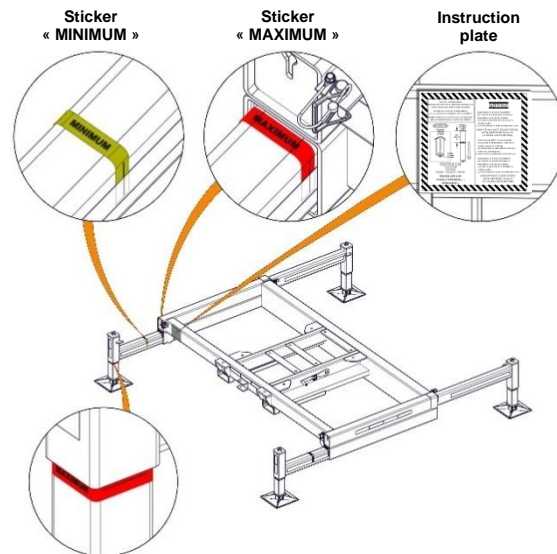


Figure 136 - Universal freestanding base stickers

## Technical data sheet of the FRSM-20K freestanding base

Note: This base can be found on older machines. Also, it is not compatible with the ground base (14030019)

Table 15 - Technical data sheet FRSM-20K freestanding base

	FRSM-20K freestanding base (14030053)	Imperial	Metric
<b>K</b>	Length (see <a href="#">Figure 139</a> )	17'-11"	5,46 m
<b>L</b>	*Maximum width (see <a href="#">Figure 139</a> )*	15'-9"	4,80 m
<b>M</b>	*Minimum width (see <a href="#">Figure 139</a> )*	7'-9"	2,36 m
<b>N</b>	Maximum height (see <a href="#">Figure 139</a> )*	2'-1 3/4"	654 mm
	Mass (freestanding base only)	2 600 lbs	1 180 kg
	Mass (lifting unit + freestanding base + first mast section)	6 060 lbs	2 750 kg
<p>*The specified widths must take into account the limits imposed by the <b>MINIMUM</b> and <b>MAXIMUM</b> stickers mentioned in the notes below.            Note: The permissible slope of the chassis is 0,5° <b>MAXIMUM</b>.            Note: There are no « <b>MINIMUM</b> » stickers (see <a href="#">Figure 138</a>).            Note: The « <b>MAXIMUM</b> » stickers (see <a href="#">Figure 138</a>) indicate the maximum opening of the outriggers.</p>			

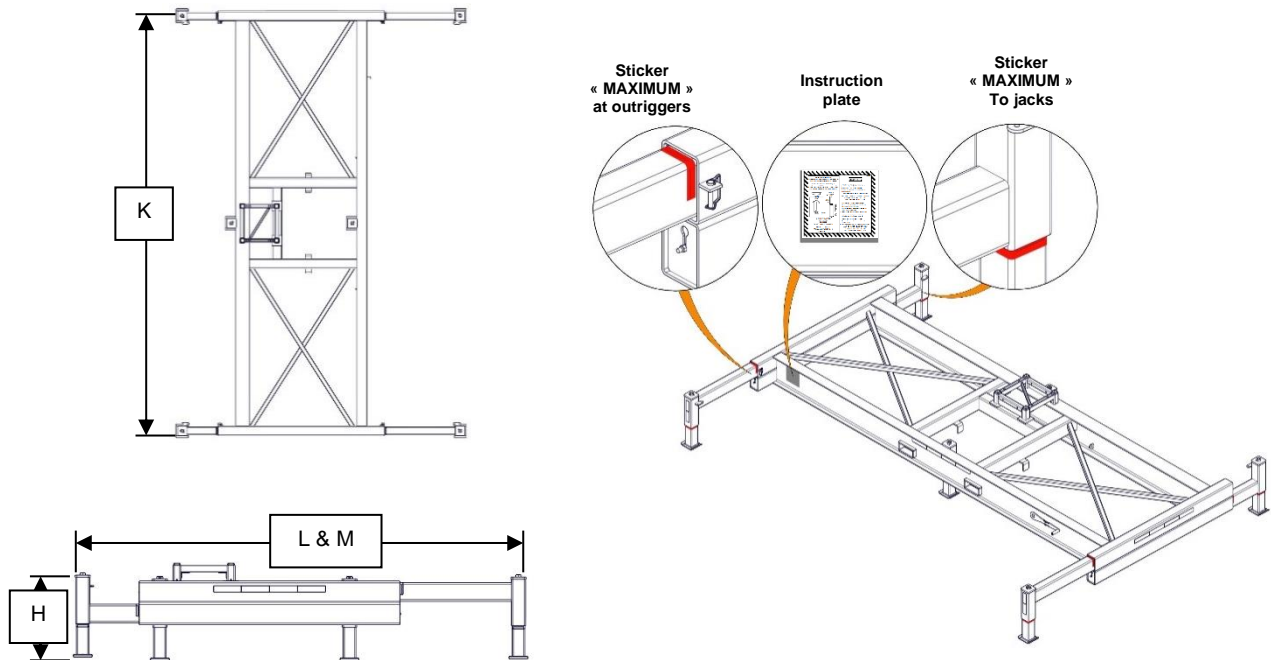


Figure 139 - ACT-8 freestanding base dimensions

Figure 138 - 20K freestanding base stickers

### Mast sections technical data sheet

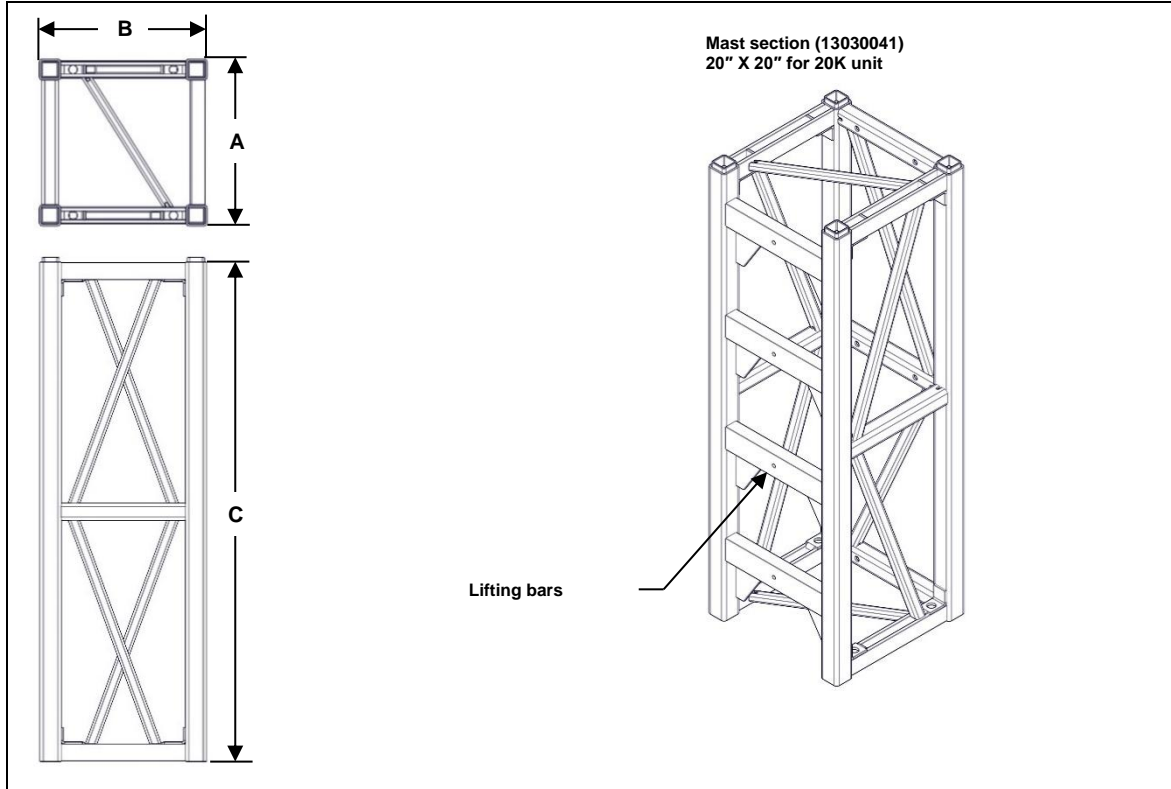


Figure 140 - 20K mast section

Table 16 - Technical data sheet 20K mast section

	Mast section with bars (13030041)	Imperial	Metric
A	Length (see <a href="#">Figure 140</a> )	20"	0,5 m
B	Width (see <a href="#">Figure 140</a> )	20"	0,5 m
C	Height (see <a href="#">Figure 140</a> )	5'-0"	1,5 m
	Tightening torque	265 lb * ft	360 N * m
	Weight	255 lb	115 kg
	<p><b>Note:</b> The maximum working height of a mast assembled on a freestanding base (without anchors) is 45'-0" (13,7 m).</p> <p><b>Note:</b> Use a forklift truck, crane truck or self-erecting system to install the masts.</p> <p><b>Note:</b> When installing the masts, ensure the rails are all oriented in the proper direction.</p> <p><b>Do not exceed the following vertical tolerances:</b>                      1/2" (13 mm) for a 10'-0" assembled mast (3,0 m)                      3/4" (19 mm) for a 20'-0" assembled mast (6,1 m)                      1" (25 mm) for a mast assembled to the maximum permitted height</p>		

## Distance between the masts

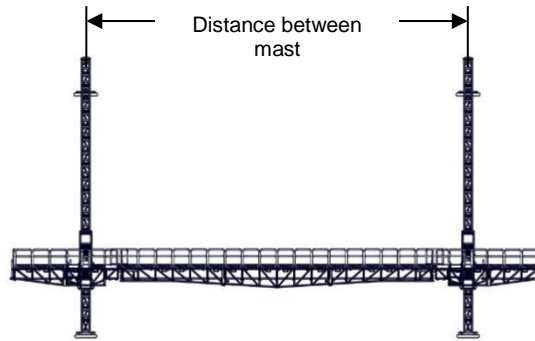


Table 17 - Distance between the masts

Configuration	Min distance	Standard distance	Max distance
Bridge section 20'-0" (6,1 m)	24'-5" (7,44 m)	24'-8" (7,51 m)	24'-11" (7,59 m)
Bridge section 20'-0" (6,1 m) + one (1) cantilever section 2'-6" (0,75 m)	26'-11" (8,20 m)	27'-2" (8,28 m)	27'-5" (8,36 m)
Bridge section 20'-0" (6,1 m) + two (2) cantilever section of 2'-6" (0,75 m) or one (1) cantilever section of 5'-0" (1,5 m)	29'-5" (8,97 m)	29'-8" (9,04 m)	29'-11" (9,12 m)
Bridge section 20'-0" (6,1 m) + one (1) cantilever section of 2'-6" (0,75 m) and one (1) cantilever section of 5'-0" (1,5 m)	31'-11" (9,73 m)	32'-2" (9,80 m)	32'-5" (9,88 m)
Bridge section 20'-0" (6,1 m) + two cantilever section of 5'-0" (1,50 m)	34'-5" (10,49 m)	34'-8" (10,57 m)	34'-11" (10,64 m)
Bridge section 40'-0" (12,2 m)	44'-4" (13,51 m)	44'-10" (13,67 m)	45'-4" (13,82 m)
Bridge section 40'-0" (12,2 m) + one (1) cantilever section of 2'-6" (0,75 m)	46'-10" (14,27 m)	47'-4" (14,43 m)	47'-10" (14,58 m)
Bridge section 40'-0" (12,2 m) + two (2) cantilever section of 2'-6" (0,75 m) or one (1) cantilever section of 5'-0" (1,5 m)	49'-4" (15,04 m)	49'-10" (15,19 m)	50'-4" (15,34 m)
Bridge section 40'-0" (12,2 m) + one (1) cantilever section of 2'-6" (0,75 m) and one (1) cantilever section of 5'-0" (1,5 m)	51'-10" (15,80 m)	52'-4" (15,95 m)	52'-10" (16,10 m)
Bridge section 40'-0" (12,2 m) + two cantilever section of 5'-0" (1,50 m)	54'-4" (16,56 m)	54'-10" (16,71 m)	55'-4" (16,87 m)
Bridge section 60'-0" (18,3 m)	64'-4" (19,61 m)	64'-10" (19,76 m)	65'-4" (19,91 m)
Bridge section 60'-0" (18,3 m) + one (1) cantilever section of 2'-6" (0,75 m)	66'-10" (20,37 m)	67'-4" (20,52 m)	67'-10" (20,68 m)
Bridge section 60'-0" (18,3 m) + two (2) cantilever section of 2'-6" (0,75 m) or one (1) cantilever section of 5'-0" (1,5 m)	69'-4" (21,13 m)	69'-10" (21,29 m)	70'-4" (21,44 m)
Bridge section 60'-0" (18,3 m) + one (1) cantilever section of 2'-6" (0,75 m) and one (1) cantilever section of 5'-0" (1,5 m)	71'-10" (21,89 m)	72'-4" (22,05 m)	72'-10" (22,20 m)
Bridge section 60'-0" (18,3 m) + two cantilever section of 5'-0" (1,50 m)	74'-4" (22,66 m)	74'-10" (22,81 m)	75'-4" (22,96 m)

**ATTENTION!**  
**AN ERROR HAS OCCURRED ON THIS PAGE. DO NOT**  
**USE THE INFORMATION ON THIS PAGE.**  
**REFER TO THE TECHNICAL BULLETIN AT THE**  
**BEGINNING OF THIS MANUAL.**



## Extensions and bridges (non-modular)

Extension section (non-modular)					
Code	Description	Weight	Length	Width	Height
15020019	28" x 43" (0,7 m x 1,1 m)	300 lb (135 kg)	30" (762 mm)	43" (1,1 m)	26,5" (673 mm)
15020020	40" x 43" (1,0 m x 1,1 m)	275 lb (125 kg)	40" (1,0 m)	43" (1,1 m)	26,5" (673 mm)
15020031	80" x 43" (2,0 m x 1,1 m)	450 lb (205 kg)	80" (2,0 m)	43" (1,1 m)	26,5" (673 mm)
15020042	120" x 43" (3,0 m x 1,1 m)	640 lb (290 kg)	120" (3,0 m)	43" (1,1 m)	26,5" (673 mm)
15020086	Tapered 120" x 43" (3,0 m x 1,1 m)	1 000 lb (455 kg)	120" (3,0 m)	43" (1,1 m)	24,5" / 40" (622 mm / 1,0 m)
Bridge section (non-modular)					
Code	Description	Weight	Length	Width	Height
15020053 (former code)	180" x 43" (4,6 m x 1,1 m) (hybrid)	1 200 lb (545 kg)	180" (4,6 m)	43" (1,1 m)	30" / 38" (762 mm / 953 mm)
15020064 (Former code)	240" x 43" (6,1 m x 1,1 m) (hybrid)	1 675 lb (760 kg)	240" (6,1 m)	43" (1,1 m)	30" / 38" (762 mm / 953 mm)
15020097	180" x 43" (4,6 m x 1,1 m) (hybrid)	1 200 lb (545 kg)	180" (4,6 m)	43" (1,1 m)	30" / 38" (762 mm / 953 mm)
15020109	240" x 43" (6,1 m x 1,1 m) (hybrid)	1 675 lb (760 kg)	240" (6,1 m)	43" (1,1 m)	30" / 38" (762 mm / 953 mm)
15020075	Central 240" x 43" (6,1 m x 1,1 m)	1 355 lb (615 kg)	240" (6,1 m)	43" (1,1 m)	38" / 43" (953 mm / 1,1 m)

## Extensions and bridges (modular)

Extension section (modular)					
Code	Description	Weight	Length	Width	Height
15030087 / 15030010 (former codes)	28" x 70" (0,7 m x 1,8 m)	310 lb (140 kg)	28" (762 mm)	70" (1,8 m)	26,5" (673 mm)
15030098 / 15030021 (former codes)	40" x 70" (1 m x 1,8 m)	286 lb (130 kg)	40" (1 m)	70" (1,8 m)	26,5" (673 mm)
15030100 / 15030032 (former codes)	80" x 70" (2 m x 1,8 m)	595 lb (270 kg)	80" (2 m)	70" (1,8 m)	26,5" (673 mm)
15030111 / 15030043 (former codes)	120" x 70" (3 m x 1,8 m)	825 lb (375 kg)	120" (3 m)	70" (1,8 m)	26,5" (673 mm)
15060013 / 15060024 (former codes)	Tapered 120" x 70" (3 m x 1,8 m)	1210 lb (550 kg)	120" (3 m)	70" (1,8 m)	24,5" / 39,5" (622 mm / 1 m)
15090016 / 15090094	28" x 70" (0,7 m x 1,8 m)	310 lb (140 kg)	28" (762 mm)	70" (1,8 m)	26,5" (673 mm)
15090027 / 15090106	40" x 70" (1 m x 1,8 m)	286 lb (130 kg)	40" (1 m)	70" (1,8 m)	26,5" (673 mm)
15090038 / 15090117	60" x 70" (1,5 m x 1,8 m)	530 lb (240 kg)	60" (1,5 m)	70" (1,8 m)	26,5" (673 mm)
15090049 / 15090128	80" x 70" (2 m x 1,8 m)	630 lb (285 kg)	80" (2 m)	70" (1,8 m)	26,5" (673 mm)
15090050 / 15090139	120" x 70" (3 m x 1,8 m)	760 lb (345 kg)	120" (3 m)	70" (1,8 m)	26,5" (673 mm)
15090184 / 15090195	Tapered 120" x 70" (3 m x 1,8 m) (Universal)	1 150 lb (520 kg)	120" (3 m)	70" (1,8 m)	26,5" (673 mm)
15060013 / 15060024	Tapered 120" x 70" (3 m x 1,8 m)	1 210 lb (550 kg)	120" (3 m)	70" (1,8 m)	26,5" (673 mm)
20490971	Tapered extension section adaptor	550 lb (250 kg)	6,75" (170 mm)	43" (1,1 m)	40" (1 m)
Bridge section (modular)					
Code	Description	Weight	Length	Width	Height
15030223 / 15030234 (former codes)	180" x 70" (4,6 m x 1,8 m) (Hybrid-universal)	1 540 lb (700 kg)	180" (4,6 m)	70" (1,8 m)	30" / 37,5" (762 mm / 953 mm)
15030201 / 15030212 (former codes)	240" x 70" (6,1 m x 1,8 m) (Hybrid-universal)	1 880 lb (855 kg)	240" (6,1 m)	70" (1,8 m)	30" / 37,5" (762 mm / 953 mm)
15030166 / 15030177 (former codes)	180" x 70" (4,6 m x 1,8 m) (hybrid)	1 290 lb (585 kg)	180" (4,6 m)	70" (1,8 m)	30" / 37,5" (762 mm / 953 mm)
15030144 / 15030155 (former codes)	240" x 70" (6,1 m x 1,8 m) (hybrid)	1 700 lb (770 kg)	240" (6,1 m)	70" (1,8 m)	30" / 37,5" (762 mm / 953 mm)
15030054 / 15030133	180" x 70" (4,6 m x 1,8 m)	1 500 lb (680 kg)	180" (4,6 m)	70" (1,8 m)	30" / 37,5" (762 mm / 953 mm)
15090205 / 15090206	240" x 70" (6,1 m x 1,8 m)	1 690 lb (765 kg)	240" (6,1 m)	70" (1,8 m)	30" / 37,5" (762 mm / 953 mm)
15030076	Central 240" x 70" (6,1 m x 1,8 m)	1 650 lb (750 kg)	240" (6,1 m)	70" (1,8 m)	37,5" / 43" (953 mm / 1,1 m)
15090229 / 15090230	180" x 70" (4,6 m x 1,8 m) (Hybrid-universal)	1 540 lb (700 kg)	180" (4,6 m)	70" (1,8 m)	30" / 37,5" (762 mm / 953 mm)
15090207 / 15090218	240" x 70" (6,1 m x 1,8 m) (Hybrid-universal)	1 880 lb (855 kg)	240" (6,1 m)	70" (1,8 m)	30" / 37,5" (762 mm / 953 mm)
15090061 / 15090140	180" x 70" (4,6 m x 1,8 m) (hybrid)	1 290 lb (585 kg)	180" (4,6 m)	70" (1,8 m)	30" / 37,5" (762 mm / 953 mm)
15090072 / 15090151	240" x 70" (6,1 m x 1,8 m) (hybrid)	1 885 lb (855 kg)	240" (6,1 m)	70" (1,8 m)	30" / 37,5" (762 mm / 953 mm)

## Periodic maintenance

### IMPORTANT NOTE

The frequency and extent of periodic testing and evaluations depends on national regulations, manufacturer specifications, operating conditions and frequency of use. Normally, it is not necessary to dismantle parts during periodic reviews, unless a doubt exists as to reliability and safety. Removal of hoods, the opening of observation hatches and the lowering of the platform to its transport position are not considered as part of a disassembly operation.

### IMPORTANT:

Before servicing, be sure to observe the following:

- Turn off the main power supply (for example, remove the main plug or turn the key to the « OFF » position) and secure the access to prevent any unintentional restart.
- Physically secure the unit if work must be done under it.
- Only a qualified and certified FRACO mechanic may perform the maintenance and/or repair.
- Replace the disassembled parts when the operation is complete.

### Daily

- Check the fuel tank level (if applicable).
- Check the base horizontal level and mast vertical level with a 1 m spirit level (in both directions).
- Remove cement or dry mortar deposits that may prevent proper operation of the platform.

### Weekly

- Check the hydraulic and engine oil levels (if applicable).
- Check the hydraulic hoses to ensure there are no oil leaks.
- Check that there is no metal deformation in parts such as extension sections, mast sections, base, hooks, etc. Deformation may occur as a result of improper handling.

### Monthly

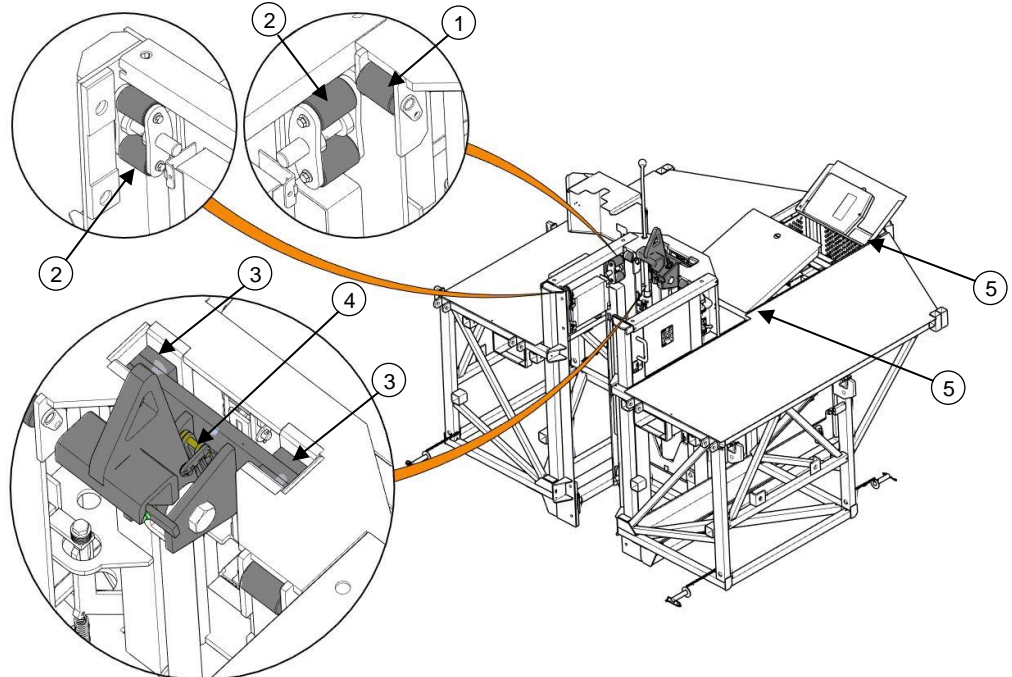
- Refer to the inspection sheet of the model-specific service manual and serial number.

### Other

As part of a platform maintenance operation, it is recommended to lubricate the following points:

Use a penetrating oil lubricant, such as: Castrol Chain Lubricant

- 1- Roller
- 2- Tandem rollers
- 3 - Carriage guide
- 4 - Mobile component of the carriage hook
- 5 - Pivot point of the doors



### Daily inspection grid

<b>Name of user:</b>		<b>Name of site:</b>	
<b>Address of site:</b>			
<b>Number / street</b>	<b>City</b>	<b>Province/State</b>	
<b>Type of lifting unit:</b> Single mast <input type="checkbox"/> Double mast <input type="checkbox"/>		<b>serial #:</b>	
<b>Autostable</b> <input type="checkbox"/>		<b>Walls attachments</b> <input type="checkbox"/>	
<b>FRH on lifting unit</b> <input type="checkbox"/>		<b>serial #:</b>	
<b>Note: Mark the verified items with your initials and indicate N/A when not applicable</b>			
Inspected items		Checked	Comments
Ground safety perimeter			
Stability of the floor surrounding the base of the platform			
Levelling of the base and verticality of the mast			
Stabilizers/wooden blocks			
Tires and Wheels / Steering, Drives			
Lateral and vertical clearance of the platform			
Condition of platform power cable			
Structure of bridge and extension sections			
Mast structure (rail/bars)			
Safety bolts, nuts and pins			
Condition of platform floor			
Condition of plankings/ planking attachments in place			
Outriggers			
Guardrails and protective wire mesh			
Mast end and mechanical descent stop			
Anchor strength: bolts and pins in place			
Loads distribution on the platform			
Warning sign/stickers			
Fuel/engine and hydraulic oil level			
Condition of hydraulic hoses			
Presence of leaks			
Condition of electrical wiring			
Battery and cables securely fixed			
User Manual, Daily inspection grid			
Platform Operation / Safety Mechanism			
HFR Operation, Cable and hook status			
Load maintained			
Emergency stop button			
Emergency descent			
<b>Comments:</b>			
<b>Date</b>		<b>Name of operator:</b>	
<b>Name of employee:</b>		<b>Signature of operator:</b>	

Any irregularity or malfunction of the platform must be corrected by a qualified and FRACO certified installer or mechanic before the platform is returned into service. A complete inspection of the platform must be carried out every 3 months.

## Spare parts

When ordering spare parts, please provide the following information available on the nameplate of the elevating unit:

∞SEE IDENTIFICATION AND SERIAL NUMBER PLATE, ON PAGE 14

- Model
- Year of manufacture
- Serial number
- Operating Voltage (if electrical)
- Required part number

### NOTE:

The spare parts must comply with the manufacturer's technical specifications. Only use genuine FRACO spare parts. Contact our customer service department to place an order for spare parts

### Les Produits FRACO Ltée

91, chemin des Patriotes  
Saint-Mathias-sur-Richelieu  
Quebec, J3L 6B6, Canada

[www.fraco.com](http://www.fraco.com)

Tel.: +1 (450) 658-0094

Toll free: 1-800-267-0094 / USA 1-888-FRACO 4U

France: + 33 (0)3 44.91.03.53

## Assistance

Problem	Engine	Potential cause	Solution
The engine will not start	D / G / E	Emergency stop activated	Reactivate emergency stop
	D	Glow plug	Replace glow plugs
	G	Engine oil level too low	Add oil in the engine
		Plug burned	Replace spark plugs
	D / G	No fuel in the tank	Place fuel in tank
		Dead battery	Boost or replace the battery
		Fuel contaminated with water or other	Empty tank and fill with clean fuel
		Filter/feed hose blocked	Unblock hose/replace or clean fuel filter
The engine is running, but the platform does not lift	D / G / E	Accessory switch in « off/Arrêt » or « on/Marche » position	Return the selector switch to the « off/Arrêt » position
		Too much load or load poorly distributed	Remove excess material and/or distribute in compliance with charter ∞SEE PERMITTED CONFIGURATIONS AND LOAD DISTRIBUTION, ON PAGE 18
The platform does not go up or down	E	Key is in « OFF » position	Turn the key to the « ON » position
The motor does not start and the « Phase » LED is lit	E	Reverse phases	Turn the phase selector located on the side of the electrical box
The engine will not start. The tank was dry and was filled	D	Presence of air in the fuel system	Perform bleeding procedure (see maintenance manual)
The engine emits smoke	D / G	Too much engine oil	Check the engine oil level
Engine starts, but stops or does not run properly	G	Choke in « ON » position	Return choke to the « CLOSED » position
Engine starts but stops quickly	D / G	Engine too cold	Allow the engine to warm up

Engine type: **D** = Diesel                      **G** = Gasoline\*                      **E** = Electric

For more information, see the platform maintenance guide.

**Important!** All equipment repairs must be carried out by a FRACO technician or one of its representatives.

\*Gas model available in some countries only.

**Table 18 - Load deductions**

Description	Load
FRH2500/FRH4000	1 350 lb (612 kg)
Monorail on platform	48 lb-ft (71,5 kg/m)
Winter shelter *	9 lb-ft (161 kg/m)
Rigid roof	31 lb-ft (555 kg/m)
Planking **	8.8 lb-ft (157,5 kg/m)
Weight of a worker	176 lb (80 kg)
Weight of a worker's equipment ***	88 lb (40 kg)

\*It is also necessary to add the weight of the canvas to the total load.

\*\*The weight for typical 2" (51 mm) x 10" (254 mm) planks is taken into account.

\*\*\*The load of equipment per worker is considered only for a **MAXIMUM** of two (2) workers, or 176 lb (80 kg).

## CE Declaration

# FRACO

Les Produits FRACO Ltée

91. Chemin des Patriotes. St-Mathias-Sur-Richelieu. Quebec. Canada J3L 6B6  
 Tel: (450) 658-0094 Fax: (450) 658-8905 CDA: 1-800-267-0094 USA 1-888-372-2648  
 www.fraco.com Email: [fraco@fraco.com](mailto:fraco@fraco.com)

## CE COMPLIANCE STATEMENT

**No. 0060 / 5162 / 760 / 01 / 10 / 1303 / REV01**

**Type:**

**Apparatus for lifting persons or persons and objects, with a vertical drop risk greater than 3 meters.  
 Hydraulic work platform moving along a mast, single and double masts.**

**Brand: FRACO Model: 20K**

**Serial number:**

**Technical details:**

In single mast:

- Nominal load / No. of persons: 4 535kg / 5 people
- Maximum height: 13,7 m (freestanding) —168 m (with anchors)
- Platform Length/Width: 14,5 m / 3,4 m
- Reduced load in single mast: 2 268 kg / 3 persons at max length (20,6 m)

In double mast:

- Nominal load / No. of persons: 9 070kg / 10 people
- Maximum height: 18,3 m (freestanding) —168 m (with anchors)
- Platform Length/Width: 38,4 m / 3,4 m
- Reduced load in double mast: 4 535kg / 7 people at max length (40,7 m)

This model satisfies all the relevant provisions of Directive 2006/42/EC (95 16. EC modified) on the approximation of the laws of the Member States relating to machines. This model meets the essential health and safety requirements applicable to it. This declaration relates exclusively to machines in the state in which they were placed on the market and excludes added components and/or subsequent operations performed by the end-user.

**Notified body**

**APAVE Parisienne SAS**

Identification number: 0060

17, rue Salneuve - 75854 PARIS CEDEX 17

**Technical file**

**SARL Fraco**

420 rue des Érables - F-60710 CHEVRIERES FRANCE

Director of Operations  
**Les Produits FRACO Ltée**  
**Emmanuelle Rainville**

St-Mathias-Sur-Richelieu  
 December 31, 2015

**ORIGINAL NOTICE**



## Lists of figures

Figure 1 - FRSM-20K single-mast with freestanding base .....	7
Figure 2 - FRSM-20K two-mast with freestanding base .....	8
Figure 3 - Regulatory attachment points .....	9
Figure 4 - Dimensions with ground base .....	10
Figure 5 - Dimensions with freestanding base .....	11
Figure 6 - Clearance to finished walls and around the units .....	12
Figure 7 - Identification Plate .....	14
Figure 8 - Plate and Serial Number location .....	14
Figure 9 - Emergency descent sticker .....	15
Figure 10 - Engine choke sticker .....	15
Figure 11 - Choke knob .....	15
Figure 12 - Valve selector sticker .....	15
Figure 13 - Hydraulic oil sticker .....	15
Figure 14 - Harness attachment point .....	15
Figure 15 - Emergency descent sticker .....	15
Figure 16 - Documentation compartment .....	16
Figure 17 - Platform areas .....	18
Figure 18 - Single-mast, full masonry load .....	19
Figure 19 - Single-mast, typical reduced load .....	20
Figure 20 - Single-mast, typical full load .....	20
Figure 21 - Example, distribution zones per unit (single-mast) .....	21
Figure 22 - Double mast, full masonry load .....	22
Figure 23 - Double mast, typical full load .....	23
Figure 24 - Double mast, typical reduced load .....	23
Figure 25 - Example, distribution zones per unit .....	24
Figure 26 - Example of load distribution .....	24
Figure 27 - FRSM-20K control box .....	28
Figure 28 - Old FRSM-20K control box (REFERENCE) .....	28
Figure 29 .....	29
Figure 30 .....	29
Figure 31 .....	29
Figure 32 .....	29
Figure 33 .....	29
Figure 34 .....	29
Figure 35 - Inclinator .....	30
Figure 36 - (Lifting) .....	32
Figure 37 - (Lifting) .....	32
Figure 38 - (Lifting) .....	32
Figure 39 - (Descent) .....	33
Figure 40 - (Descent) .....	33
Figure 41 - (Descent) .....	33
Figure 42 - Load distribution, universal freestanding base .....	35
Figure 43 - Load distribution, 20K freestanding base .....	36
Figure 44 - Lift points, 20K .....	38
Figure 45 - Lift points, ground base (14030019) .....	38
Figure 46 - Lift points, universal freestanding base (14030109) .....	38
Figure 47 - Lift points, universal freestanding base (14030053) .....	38
Figure 48 - Mast end section .....	39
Figure 49 .....	39
Figure 50 .....	39
Figure 51 - Use of slings and belts .....	40
Figure 52 - Crushed stone foundation .....	41
Figure 53 - Unit installation on ground base .....	41
Figure 54 - Installation of universal freestanding base .....	42
Figure 55 - Installation of ground base on universal freestanding base .....	43
Figure 56 - Installation of mast bolted base on universal freestanding base .....	43
Figure 57 - Installation of 20K freestanding base .....	44
Figure 58 - Installation of access guardrail .....	45
Figure 59 - Assembling the ladder and access guardrail .....	45
Figure 60 - Closing the ladder and access guardrail .....	45
Figure 61 - MODULAR extension section .....	48
Figure 62 - MODULAR tapered (universal) extension section .....	48
Figure 63 - NON-MODULAR extension section .....	49
Figure 64 - MODULAR Extension joint .....	50
Figure 65 - Tapered extensions with protective hook supports .....	51
Figure 66 - Combination 20' -0" to 20' -0" .....	55
Figure 67 - Combination 20' -0" to centre .....	55
Figure 68 - Bridge joint with bottle .....	56
Figure 69 - Installation of 15'-0" or 20'-0" bridge section between lifting units .....	57
Figure 70 - Installation of 15'-0" or 20'-0" bridge section between lifting units and/or intermediate extensions .....	58

Figure 71 - Installation of 30'-0" to 60'-0" bridge assembly on the lifting unit and/or intermediate extensions .....	59
Figure 72 - Installation of an extension bridge section .....	60
Figure 73 - Bolting mast and mast end sections .....	61
Figure 74 - Installation of anchors on to mast .....	71
Figure 75 - Dismantling of masts and anchors, ground base .....	75
Figure 76 - Installation of masts and anchors on a ground base, self-erecting (optional) .....	76
Figure 77 - Installation of masts and anchors, freestanding base.....	78
Figure 78 - Installation of masts and anchors on a freestanding base, self-erecting (optional) .....	79
Figure 79 - Self-erecting assembly .....	80
Figure 80 - Levelling with anchor devices .....	81
Figure 81 - protective wire mesh.....	82
Figure 82 - Dismantling masts and anchors and ground base .....	84
Figure 83 - Dismantling masts and anchors, freestanding base (universal, 20K) .....	86
Figure 84 - Installing guardrails.....	87
Figure 85 - Installing outriggers .....	88
Figure 86 - Outrigger extension .....	89
Figure 87 - Spacing between outriggers .....	90
Figure 88 - Installation of NON-REINFORCED upper outriggers .....	91
Figure 89 - Installation of lower outriggers .....	91
Figure 90 - Installation of REINFORCED upper outriggers .....	92
Figure 91 - Detail of planking installation .....	93
Figure 92 - Outrigger support .....	94
Figure 93 - Installation of outrigger-end guardrail.....	95
Figure 94 - Installing mast anchor guardrails .....	96
Figure 95 - Anti-pivot device (small wheel) .....	97
Figure 96 - Anti-pivot device (large wheel).....	98
Figure 97 - Descent stop device .....	99
Figure 98 - Inclinometer.....	100
Figure 99 - Corner return, installation .....	101
Figure 100 - Corner return, installation .....	102
Figure 101 - Corner return, installation of the counterweight.....	103
Figure 102 - Installation of work supports on tapered extension section or bridge section.....	104
Figure 103 - Installation distance of counterweight for corner return work support .....	105
Figure 104 - Installation of counterweight outrigger .....	105
Figure 105 - Installing the indoor working system .....	106
Figure 106 - Rigid roof system.....	107
Figure 107 - Rigid roof system, installation of supports.....	108
Figure 108 - Rigid roof system, installation of plywood supports .....	109
Figure 109 - Rigid roof system, installation of canvas partitions .....	110
Figure 110 - Rigid roof system, upper work area .....	111
Figure 111 - Rigid roof system, heating cage.....	112
Figure 112 - Winter shelter system .....	113
Figure 113 - Winter shelter system, installation of supports .....	114
Figure 114 - Winter shelter, heating cage .....	116
Figure 115 - Monorail installation.....	118
Figure 116 - Mast head monorail .....	122
Figure 117 - Mast head monorail, installation .....	123
Figure 118 - Installation of a mast head monorail .....	124
Figure 119 - Installation of a mast head monorail .....	125
Figure 120 - Option 1, load Distribution, mast head monorail.....	126
Figure 121 - Option 2, load distribution, mast head monorail .....	126
Figure 122 - Installation of a mast head monorail .....	127
Figure 123 - FRH-2500 Crane, loading area.....	131
Figure 124 - FRH-2500 Crane, maintenance .....	132
Figure 125 - FRH-4000 Crane, installation.....	135
Figure 126 - FRH-4000 Crane, loading area.....	136
Figure 127 - FRH-4000 Crane, maintenance.....	137
Figure 128 - Mobile base, with engine .....	139
Figure 129 - Mobile base, traction .....	140
Figure 130 - Mobile base, installation of traction arm .....	141
Figure 131 - Mobile base, installation of wheels.....	142
Figure 132 - Mobile base, unit installation.....	143
Figure 133 - Mobile base operating sticker (30060290) .....	145
Figure 134 - Lifting unit dimensions .....	146
Figure 135 - Ground base dimensions.....	147
Figure 136 - Universal freestanding base stickers .....	148
Figure 137 - Universal freestanding base dimensions.....	148
Figure 138 - 20K freestanding base stickers.....	149
Figure 139 - ACT-8 freestanding base dimensions .....	149
Figure 140 - 20K mast section.....	150